

Appendix Q – Accessibility Design Standards, City of Winnipeg, May 2010

2010 CITY OF WINNIPEG
ACCESSIBILITY DESIGN STANDARDS

ACKNOWLEDGEMENTS

ACKNOWLEDGEMENTS

May 2010

Re: the Revised 2010 City of Winnipeg Accessibility Design Standards



Dear Reader/User of these Standards,

On behalf of the City of Winnipeg Universal Design office, we are pleased to present the 2010 revised City of Winnipeg Accessibility Design Standard. The design standards presented in this manual are intended to apply to all newly constructed and/or renovated facilities, owned, leased or operated by the member organizations of the City of Winnipeg. We would like to thank and recognize the following contributors:

- Members of the City of Winnipeg staff technical review committees and document developer Leanne Muir
- Members of the Access Advisory Committee and others in the community who volunteered their time to review the content and contribute expertise
- Mr. Bob Topping, Matthew Fleet and other staff of Designable Environments Inc. who developed the 2006 City of Winnipeg Accessibility Design Standards, used as the base for these revised standards.



The following documents are/were referenced within and/or while making this design standard

2001 Facility Accessibility Design Standards for the City of London



City of Edmonton Play Area Accessibility Design Standard
Manitoba Building Code

Barrier-Free Design Guidelines - Alberta Safety Codes Council

Access: A Guide to Accessible Design for Designers, Builders, Facility Owners and Managers - Universal Design Institute, 2000

National Building Code of Canada
Geometric Design Guide for Canadian Roads - 1999, Part 1 + 2

Barrier-Free Design Standards - Regional Municipality of Hamilton -Wentworth and the Corporation of the City of Hamilton

City of Toronto Accessibility Design Guidelines

Joint Municipal Guidelines for Accessibility for the Towns of Richmond Hill, Markham and Vaughan

Children's Play Spaces and Equipment - CAN/CSA Z614

Barrier-Free Design Guidelines - City of North York

City of Winnipeg Transit Design Guidelines for Safe and Accessible Bus Stops

Metric Handbook Planning and Design Data, Second Edition

Barrier-Free Design- CAN/CSA-B651-04

City of Winnipeg Standard Construction Specifications - <http://winnipeg.ca/matmgt/Spec/Default.stm>

Illuminating Engineering Society of North America Standards

Accessibility Guidelines for Buildings and Facilities (ADAAG) - The American with Disabilities Act

Public Works E-specifications, Section E1, Supply and Install Detectable Warning Surface

Standards and Guidelines for the Conservation of Historic Places in Canada

Province of Manitoba Highway Traffic Act

Manual of Uniform Traffic Control Devices for Canada

Winnipeg Public Historic Places

Canadian National Institute of the Blind
Clear Print Guidelines

In addition to our use of this manual for our own facilities, we encourage the use of the 2010 City of Winnipeg Accessibility Design Standard throughout the community and hope that you find them interesting and valuable for your facility construction and/or renovation projects.

City of Winnipeg

TABLE OF CONTENTS

Introduction	7
Glossary and Definitions	11
Scope and Application	19

Design Standards

1.0 General Design Standards	23
---	----

1.1 General Access and Circulation

1.1.1 Space and Reach Requirements	24
1.1.2 Protruding and Overhead Objects	28
1.1.3 Accessible Routes, Paths and Corridors	30
1.1.4 Gates, Turnstiles and Openings	34
1.1.5 Ramps	36
1.1.6 Stairs	40
1.1.7 Handrails and Guards	42

1.2 General Information and Communication Systems

1.2.1 Texture, Finishes and Colour	44
1.2.2 Acoustics	45
1.2.3 Public Address Systems	46
1.2.4 Signage	47
1.2.5 Information Systems	50
1.2.6 Detectable Warning Systems	52

1.3 General Amenities

1.3.1 Drinking Fountains	54
1.3.2 Vending and Ticketing Machines	56
1.3.3 Public Telephones	57
1.3.4 Elevated Areas and Platforms	60
1.3.5 Waiting and Queuing Areas	62
1.3.6 Benches	63

1.4 General Context Specific Requirements

1.4.1 Swimming Pools	66
1.4.2 Public Historic Places	68
1.4.3 Fixed Seating Assembly Facilities	69

TABLE OF CONTENTS

2.0 Exterior Design Standards	73	3.2.5 Storage, Shelving and Display Units	142
2.1 Exterior Access and Circulation		3.2.6 Specialty Change Rooms	143
2.1.1 Exterior Ground Surfaces	74	3.2.7 Lockers and Storage Units	145
2.1.2 Exterior Lighting	77	3.3 Washroom Facilities	
2.1.3 Streetscape	78	3.3.1 Toilet and Bathing Facilities	146
2.1.4 Traffic Signal Poles	81	3.3.2 Toilet Stalls	148
2.1.5 Curb Ramps and Truncated Dome Detectable Warning Surfaces	83	3.3.3 Toilets	150
2.2 Exterior Amenities		3.3.4 Lavatories	152
2.2.1 Balconies, Plazas and Patios	87	3.3.5 Urinals	154
2.2.2 Plantings	90	3.3.6 Washroom Accessories	156
2.2.3 Picnic Tables	91	3.3.7 Individual Washrooms	158
2.2.4 Dog Relief Areas	93	3.3.8 Grab Bars	161
2.3 Exterior Context Specific Requirements		3.3.9 Shower Stalls	162
2.3.1 Parking	94	3.4 Interior Information and Communication Systems	
2.3.2 Passenger Loading Zones	98	3.4.1 Visual Alarms	164
2.3.3 Outdoor Recreational Facilities	100	3.4.2 Assistive Listening Systems	165
2.3.4 Transit Facilities	104	3.5 Interior Systems and Controls	
2.3.5 Play Areas	106	3.5.1 Controls and Operating Mechanisms	166
3.0 Interior Design Standards	109	3.5.2 Card Access, Safety and Security Systems	168
3.1 Interior Access and Circulation		3.5.3 Interior Lighting	169
3.1.1 Interior Floor Surfaces	110	3.5.4 Interior Glare and Light Sources	170
3.1.2 Entrances	112	3.6 Interior Context Specific Requirements	
3.1.3 Doors	114	3.6.1 Arenas, Gymnasiums, Halls and Other Indoor Recreational Facilities	171
3.1.4 Windows, Glazed Screens and Sidelights	121	3.6.2 Cafeterias	172
3.1.5 Elevators	123	3.6.3 Libraries	174
3.1.6 Platform Lifts	127	3.6.4 Cashiers and Workplace Accommodations	177
3.1.7 Escalators	129	3.6.5 Emergency Services	178
3.1.8 Emergency Exits, Fire Evacuation and Areas of Rescue and Assistance	130	3.6.6 Public Housing	180
3.2 Interior Amenities		3.6.7 Training Facilities	181
3.2.1 Information, Reception and Service Counters	132	Appendix A Universal Design Principles	185
3.2.2 Tables, Counters and Work Surfaces .	134	Appendix B Change Order Form	189
3.2.3 Offices, Work Areas and Meeting Rooms	136	Index	193
3.2.4 Kitchens and Kitchenettes	137		

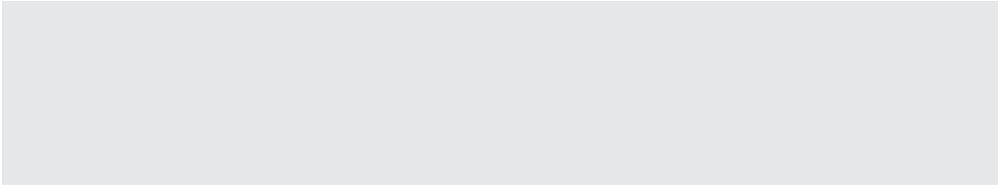

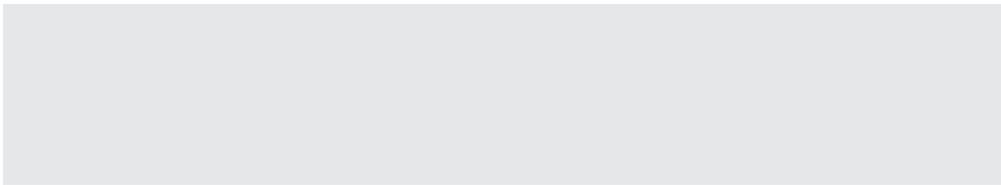

INTRODUCTION

INTRODUCTION

INTRODUCTION

This design standard addresses accessibility requirements for the design and construction of new *facilities*, as well as the *retrofit*, *alteration* or *addition* to existing *facilities*, owned, leased or operated by the City of Winnipeg. It supports the City of Winnipeg's Universal Design Policy. The document addresses a diverse range of user needs, including people with *disabilities*. It embraces the spirit of universal design through the creation of inclusive environments.

This design standard is intended to encompass the intent of the 'Manitoba Human Rights Code', in terms of respecting the dignity of persons with *disabilities*. "The phrase 'respects their dignity' means to act in a manner which recognizes the privacy, confidentiality, comfort, autonomy and self-esteem of persons with *disabili-*

ties, which maximizes their integration and which promotes full participation in society" (Ontario Human Rights Commission).

This design standard incorporates the belief in universal design that recognizes the broad diversity of people who use *facilities*. Universal design is defined as: "The design of products and environments to be usable by all people, to the greatest extent possible, without the need for adaptation or specialized design" (Mace, R., 1983).

The universal design philosophy is structured around the seven design principles listed below.

This design standard reflects minimum dimensional criteria required for adult persons. Prior to the design stage of a project, consideration should be given to the function of the *facility* and the people who will use it. A

review and upgrade of the design standards presented in this manual may be required in some instances, particularly if a *facility* is designed primarily for the use of a particular type of user, such as children or older persons.

Where conflicts exist between scoping and/or dimensional requirements of this design standard and standards or legislation enacted by the federal or provincial governments, the most accommodating requirements shall apply (i.e. the requirement(s) that will result in the most accommodating environment, but never less than the minimum requirements of the *MBC*), provided federal or provincial approvals are obtained where required.

The City of Winnipeg shall review and/or update this design standard at least every 2 years, or as deemed necessary to reflect user feedback, technological advance-

1. EQUITABLE USE:

The design is useful and marketable to people with diverse abilities.

2. FLEXIBILITY IN USE:

The design accommodates a wide range of individual preferences and abilities.

3. SIMPLE AND INTUITIVE USE

Use of the design is easy to understand, regardless of the user's experience, knowledge, language skills, or current concentration level.

4. PERCEPTIBLE INFORMATION:

The design communicates necessary information effectively to the user, regardless of ambient conditions or the user's sensory abilities.

5. TOLERANCE FOR ERROR:

The design minimizes hazards and the adverse consequences of accidental or unintended actions.

6. LOW PHYSICAL EFFORT:

The design can be used efficiently and comfortably with a minimum of fatigue.

7. SIZE AND SPACE FOR APPROACH AND USE:

Appropriate size and space are provided for approach, reach, manipulation and use, regardless of user's body position, size, posture or mobility.

ment and new construction practices, as well as changes to the barrier-free design requirements of various codes and standards such as the *MBC* and the CSA Standard B651 - 'Accessible Design for the Built Environment'.

This design standard recognizes the concept of equivalent facilitation as a means to encourage new and innovative design ideas and solutions. Departures from particular technical and scoping requirements of this manual through the use of other designs and technologies is encouraged, when the alternatives will provide substantially equivalent or greater access to the usability of the *element* and/or *facility*. Design departures from information provided and referenced in this manual should be carefully assessed to determine the validity of the application and may require review by a committee appointed for this purpose by the City of Winnipeg.

Dimensions used in this manual are in metric units. Nearest imperial equivalent dimensions are in parentheses.

IMPLEMENTATION

The purpose of this manual is to serve as best practises standard necessary to further the implementation of the 'City of Winnipeg Universal Design Policy' adopted by City Council in December 2001. It is meant to accommodate both the public and employ-

ees with a variety of human factors.

The 2010 City of Winnipeg Accessibility Design Standards shall be considered a standard for new construction and/or renovations of all facilities owned or funded by the Corporation of the City of Winnipeg. It is meant to enhance the usability of facilities for a wide range of people.

For facilities that are partially owned through partnership agreements (i.e. playgrounds, weather protected walkways etc.) this Accessibility Design Standard will be provided as a recommended tool and, at minimum, reasonable access, according the Manitoba Human Rights and Manitoba Building Code, be required.

Renovations in leased space should ensure the *building* renovations adhere to the provisions in the 2010 City of Winnipeg Accessibility Design Standards.

ENFORCEMENT

The Universal Design Coordinator or a departmental designate knowledgeable in accessible design will be responsible to determine compliance with the 2010 City of Winnipeg Accessibility Design Standards. This is not meant to be prescriptive in the sense of being an impediment to creative design, but rather to encourage innovation by inviting compliance with the intent of each *element* of accessibility. Clear

explanations of how the intent of accessibility was met would be considered and welcomed.

A statement of expected accessibility outcomes must be included in all consultant requirements.

Although the design criteria used to achieve accessible and universal design in this manual may be different, it is important to ensure that all requirements of the *MBC* are also met. Where there are discrepancies between other standards and the 2010 City of Winnipeg Accessibility Design Standards, the optimum level of accessibility should be used.

All recommendations for change to this document shall be submitted using the change form in Appendix B. These recommendations along with a review of implementation through post occupancy evaluations will constitute an update every two years. Changes will only occur after careful consideration by a City of Winnipeg technical team of experts. Changes could also be triggered by updates from the National and Manitoba Building Codes and the Canadian Standards Association.

Other municipalities are welcomed and encouraged to utilize this design manual.

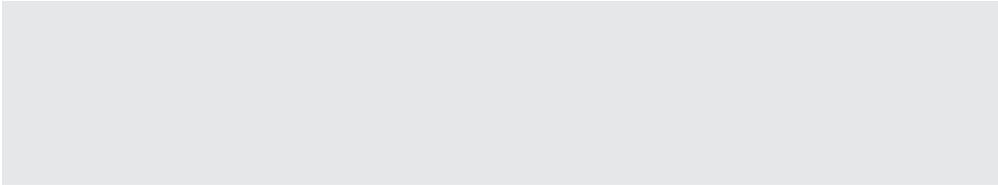

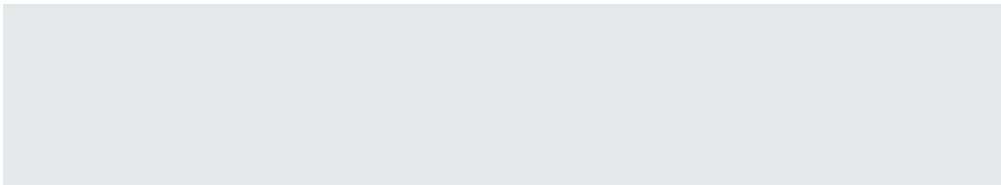

DEFINITIONS

DEFINITIONS

GRAPHIC CONVENTIONS

Dimensions that are not marked maximum or minimum are absolute, unless otherwise indicated.

Please note: the drawings in this document examples only and are not to scale.

GENERAL TERMINOLOGY

comply with

Meet one or more specifications of this manual.

if ... then

Denotes a specification that applies only when the conditions described are present.

may

Denotes an option or alternative.

shall

Denotes a mandatory specification or requirement.

should

Denotes an advisory specification or recommendation.

DEFINITIONS

Access Aisle:

An *accessible* pedestrian *space* between *elements*, such as parking *spaces*, seating and desks, that provides clearances appropriate for the use of the *elements*.

Accessible:

Describes a *site*, *building*, *facility*, *public right-of-way* or portion thereof that complies with the requirements of this design standard.

Accessible Element:

An *element* specified by this manual (for example, telephone, controls etc.).

Accessible Route:

A continuous unobstructed path connecting *accessible elements* and *spaces* of a *facility*. Interior *accessible routes* may include corridors, floors, *ramps*, elevators, platform lifts and *clear spaces* at fixtures. Exterior *accessible routes* may include parking *access aisles*, *curb ramps*, crosswalks at *vehicular ways*, *walks*, *ramps* and platform lifts.

Accessible Space:

Space that complies with the requirements of this design standard.

Active Transportation Routes:

Any transportation route intended to be used by human-powered modes of transportation such as cycling, walking, skiing, and skateboarding. The main emphasis is on travel for a

specific purpose or to a specific location. However, this definition does not exclude travel for purely recreational purposes.

Adaptable:

The ability of a certain *building space* or *element*, such as kitchen counters, sinks, and grab bars, to be added or altered so as to accommodate the needs of individuals with or without *disabilities* or to accommodate the needs of persons with different types or degrees of *disabilities*.

Addition:

An expansion, extension, or increase in the gross floor area of a *facility*.

Alteration:

A change to a *facility*, including a change of use, that affects or could affect the usability of the *facility* or part thereof. *Alterations* include, but are not limited to, remodelling, renovation, *retrofitting*, rehabilitation, reconstruction, historic restoration, resurfacing of *circulation paths* or *vehicular ways*, changes or rearrangement of the structural parts or *elements*, and changes or rearrangement in the plan configuration of walls and full-height partitions. Normal maintenance, painting or wallpapering, or changes to mechanical or electrical systems are not *alterations*, unless they affect the usability of the *building*.

Area of Rescue Assistance:

An area which has direct access to an exit, where people who are

unable to use stairs may remain temporarily in safety to await further instructions or assistance during emergency evacuation.

Assembly Area:

A room or *space* accommodating a group of individuals for recreational, educational, political, social, civic or amusement purposes, or for the consumption of food and drink.

Assistive Listening Device:

Equipment used to receive sound output from the *Assistive Listening System*.

Assistive Listening Systems:

Wireless sound transmission systems that improve sound reception for persons with hearing disabilities by providing amplification which can be adjusted by each user while blocking out unwanted background noise.

Attic Space:

The unoccupied *space* between the roof and the ceiling of the top *storey* or between a dwarf wall and a sloping roof.

Automatic Door:

A door equipped with a power-operated mechanism and controls that open and close the door automatically upon receipt of a momentary actuating signal. The switch that begins the automatic cycle may be a photoelectric device, floor mat, or manual switch. (See *Power-Assisted Door*).

DEFINITIONS

Building:

Any structure used or intended for supporting or sheltering any use or occupancy.

Cane-Detectable:

Within the detection range of a cane as it sweeps or taps.

Circulation Path:

An exterior or interior way of passage from one place to another for pedestrians, including, *walks*, hallways, courtyards, stairways, and stair landings.

Clear Path of Travel:

A way of passage which is unobstructed by vertical, visually busy horizontal patterns and/or overhanging elements.

Clear Space:

The minimum unobstructed floor or ground *space* required to accommodate a single, stationary wheelchair, scooter or other mobility device, including the user.

Closed-Circuit Telephone:

A telephone with dedicated line (s), such as a house phone, courtesy phone or phone that must be used to gain *entrance* to a *facility*.

Colour Contrast:

A significant contrast in colour between the foreground and background of an *element*, e.g., light on a dark background or dark on light background.

An eggshell finish (11 to 19 degree gloss on 60 degree glossimeter) is recommended.

Research indicates that signs are more legible for persons with low vision when characters contrast with their background by at least 70%. Contrast in percent shall be determined by:

$$\text{Contrast} = [(B_1 - B_2) / B_1] \times 100$$

where B_1 = light reflectance value (LVR) of the lighter area and B_2 = light reflectance value (LVR) of the darker area.

Note that in any application both white and black are never absolute; thus, B_1 never equals 100 and B_2 is always greater than 0.

The greatest readability is usually achieved through the use of light-coloured characters or symbols on a dark background.

Common Use:

Refers to those interior and exterior rooms, *spaces* or *elements* that are made available for use by groups of people (for example, occupants of a homeless shelter, the occupants of an office *building*, or the guests of such occupants).

Cross Slope:

The slope that is perpendicular to the direction of travel. (See *ramp slope*)

Curb Ramp:

A short *ramp* cutting through a curb or built up to a curb.

Detectable Warning:

A standardized surface feature built into or applied to walking surfaces or other *elements* to warn persons with vision *impairments* of hazards on a *circulation*

path.

Disability:

A circumstantial limitation occurring when a person's physical, social and/or institutional environment fails to accommodate their functional needs. The experience of disability can be minimized by designing environments to accommodate a range of physical and sensory capabilities.

Egress, Means of:

A continuous and unobstructed way of exit travel from any point in a *facility* to a *public right-of-way*. A *means of egress* comprises vertical and horizontal travel and may include intervening room *spaces*, doorways, hallways, corridors, passageways, balconies, *ramps*, stairs, enclosures, lobbies, horizontal exits, courts and yards.

An *accessible means of egress* is one that complies with the design requirements of this manual and does not include stairs, steps or escalators. Areas of rescue assistance, protected lobbies or protected elevators may be included as part of an *accessible means of egress*.

Element:

An architectural or mechanical component of a *building*, *facility*, *space* or *site* (e.g., telephone, *curb ramp*, door, drinking fountain, seating or water closet).

Entrance:

Any access point into a *building* or a *facility* used for the purposes of entering. An *entrance* includes the approach *walk*, the vertical

access leading to the *entrance* platform, the *entrance* platform itself, vestibules (if provided), the entry door(s) or gate(s), and the hardware of the entry door(s) or gate(s).

Facility or Facilities:

All or any portion of *buildings*, structures, *site improvements*, complexes, equipment, roads, *walks*, passageways, *parks*, parking lots or other real or personal property located on a *site*, or within a *public right-of-way*.

Ground Floor:

Any *occupiable* floor less than one *storey* above or below grade with direct access to grade. A *facility* always has at least one *ground floor* and may have more than one *ground floor*, as where a split-level *entrance* has been provided or where a *facility* is built into a hillside.

Guard:

A safety railing used as a barrier to prevent encroachment or accidental falling from heights.

Handrail:

A component which is normally grasped by hand for support at stairways and other places where needed for safety of pedestrians

Impairment:

Any loss or abnormality of psychological, physiological or anatomical structure or function.

Indicator Surface:

A ground surface that is in *colour contrast* to an adjacent *accessible route*, as well as textured differ-

ently to the surface of the *accessible route* to be *cane-detectable*.

MBC:

MBC is the abbreviation for the latest edition of the Manitoba Building Code with all amendments.

Meeting Room:

Room used for meetings, which accommodates more than six people.

Mezzanine or Mezzanine Floor:

An intermediate floor assembly between the floor and ceiling of any room or *storey* and includes an interior balcony.

Multi-Use Pathway:

A *multi-use pathway* is physically separated from motor vehicle traffic and can be either within the highway *right-of-way* or within an independent *right-of-way*. *Multi-use pathways* include bicycle paths, rail-trails or other facilities built for bicycle and pedestrian traffic.

Occupiable:

A room or enclosed *space* designed for any human occupancy in which individuals congregate for amusement, educational or similar purposes, or in which occupants are engaged at labour, and which is equipped with *means of egress*, light and ventilation.

Open Space:

Large-scale tracts of land without visible evidence of residential, commercial or industrial development. These areas may be pri-

vately or publicly owned and are generally left in a natural state and not programmed for active recreation. The benefits of open lands typically extend beyond the immediate area and usually provide community-wide benefits.

Operable Portion:

A part of a piece of equipment or appliance used to insert or withdraw objects, or to activate, deactivate, or adjust the equipment or appliance (for example, coin slot, push button, handle).

Park:

Land that is privately or publicly held that has been developed for multiple recreational and leisure-time uses. This land benefits the entire community and balances the demands of the public for outdoor recreational *facilities* and other amenities, such as pathways, plazas, picnic areas, playgrounds, water features, *spaces* for free play and leisure.

Power-Assisted Door:

A door used for human passage that has a mechanism that helps to open the door or relieves the opening resistance of a door, upon the activation of a switch or a continued force applied to the door itself.

Public Historic Place:

A publicly accessible structure, *building*, group of *buildings*, district, landscape, archaeological *site* or other place in Winnipeg that has been formally recognized by the City for its heritage value and/or identified on the Building Conservation List within the City

DEFINITIONS

of Winnipeg.

Public Right-of-Way:

A portion of public land reserved or used for a *street*, lane, walkway, *active transportation route*, park, public plaza, green space, drainage facility, natural area or other public purpose. (*Public right-of-way* does not apply to private property).

Public Use:

Describes interior or exterior rooms, *spaces* or amenities that are made available to the general public. *Public use* may be provided at a *facility* that is privately or publicly owned.

Ramp:

A walking surface which has a *ramp slope* greater than 1:20.

Ramp slope:

The slope of a *ramp* that is parallel to the direction of travel. (See *Cross Slope*).

Retrofit:

See *Alteration*.

Roof Space:

Attic area, or area between a dwarf partition and sloping roof.

Service Entrance:

An *entrance* intended primarily for delivery of goods or services and access by staff, not intended for use by the public.

Service Room:

A room provided in a *building* to contain equipment and to perform activities associated with *building* services.

Service Space:

A *space* provided in a *facility* to facilitate or conceal the installation of *facility* items such as chutes, ducts, pipes, shafts or wires.

Signage:

Displayed of written word, symbols, pictorial, *tactile* and contracted Braille information.

Site:

A parcel of land bound by a property line or a specific portion of a *public right-of-way*.

Site Improvement:

Landscaping, paving for pedestrian and *vehicular ways*, outdoor lighting, recreational *facilities* added to a *site*.

Sleeping Accommodations:

Rooms in which people sleep, for example, a dormitory.

Space:

A definable area (e.g. room, toilet room, hall, *assembly area*, *entrance*, dormitory, storage room, alcove, courtyard or lobby).

Street:

Any place or way, including any structure forming part of the place or way, which has been dedicated as a roadway, lane, avenue, footpath, walkway, road or highway pursuant to 'The Real Property Act' or which the public is ordinarily entitled to use for passage, with or without fee or charge.

Street Elements:

Street elements include pedestrian elements, such as public art, benches, bicycle racks, and waste receptacles; and service infrastructure, such as fire hydrants, street signage, and traffic signal poles, that are *accessible* for *public use* and located within a *public right-of-way*.

Street Element Zone:

The back-of-curb zone between the curb and the *clear path of travel*.

Streetscape:

The collection of elements within and along the street right-of-way that define its identity, appearance, and functionality, including street furniture, public art, landscaping, trees, sidewalks, and pavement treatments, among others.

Storey:

That portion of a *building* that is situated between the top of any floor and the top of the floor next above it, and if there is no floor above it, that portion between the top of such floor and the ceiling above it.

Structural Frame:

The columns and the girders, beams, trusses and spandrels having direct connection to the columns and all other members (exclusive of door frames) which are essential to the stability of the *building* as a whole.

Tactile:

Describes an object that can be perceived using the sense of

touch.

Technically Not Feasible:

Means, with respect to an *alteration of a building or a facility*, that it has little likelihood of being accomplished, because existing structural conditions would require moving or altering a load-bearing member which is an essential part of the *structural frame*; or other existing physical or *site* constraints prohibit modification or addition of necessary *elements, spaces* or features which are in full and strict compliance with the minimum requirements for new construction. (Lack of money is not an acceptable reason not to reduce barriers).

Temporary Facilities:

Facility that is not of permanent construction but that is extensively used, or is essential for *public use* for a period of time. Examples of *temporary facilities* covered by this manual include, but are not limited to, reviewing stands, bleacher areas, temporary kiosks, temporary health screening services, temporary safe pedestrian passageways around a construction *site* or *temporary* public art. Structures and equipment directly associated with the actual processes of construction, such as scaffolding, bridging, materials hoists, or construction trailers are not included.

Telephone Typewriter (TTY):

Telephone equipment that employs interactive text-based communication through the transmission of text across the standard telephone network.

Truncated Domes:

Small domes with flattened tops that are inset into paving as *tactile* warnings at transit platforms, curb edges, and other potential hazards.

Vehicular Way:

A route intended for vehicular traffic, such as a *street*, driveway or parking lot.

Visitable:

The ability of a dwelling unit to offer a reasonable level of access to accommodate visitors with *disabilities*, elderly persons or residents who may be temporarily *impaired* - allowing a person to access the dwelling safely via a level entry, manoeuvre through an entry door and utilize a main floor toilet.

Walk:

An exterior pathway with a prepared surface intended for pedestrian use, including general pedestrian areas, such as plazas and courts.

Wayfinding:

Wayfinding is a term used to describe the spatial problem-solving process that a person uses to reach a destination. A mental 'map' is formed of the overall setting and the desired destination. This map is based on information obtained from orientation cues that are available from the setting's environment. These cues include not only *signage*, but also overall spatial forms, structures, sounds, surface textures, colours, illumination levels, architectural

features, etc. *Wayfinding* cues

should reduce complexity and increase consistency in an environment.

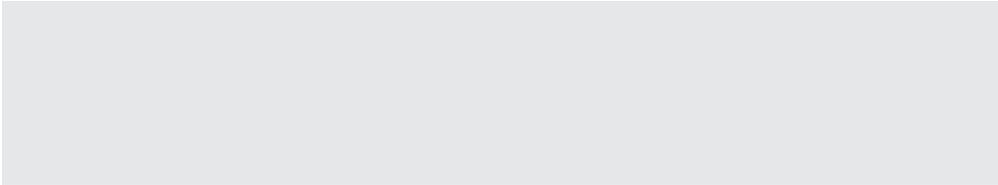

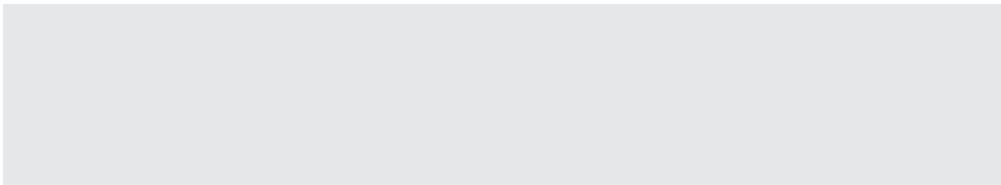

SCOPE AND APPLICATION

SCOPE AND APPLICATION

GENERAL APPLICATION

Subject to the implementation criteria specified in the document introduction, the requirements of this design standard are

- applicable to all newly constructed and *retrofitted facilities* owned, leased or operated by the member organization of the City of Winnipeg; and
- encouraged for all other *facilities*, whether new or *retrofitted*.

The design requirements of this manual do not apply to

- privately owned houses, including semi-detached houses, town houses, row houses and boarding or rooming houses with fewer than 8 boarders or roomers;
- *buildings* of Group F Division 1 occupancy, as defined by the *MBC*; and
- *buildings* which are not intended to be occupied as a place of daily or full-time activity including but not limited to automatic telephone exchanges, pump houses, sewage treatment and water treatment facilities and substations.

All areas of newly designed or newly constructed *facilities* and altered portions of existing *facilities* shall comply with this manual, unless otherwise provided in this section or as modified in Sections 1.4 General Context Specific

Requirements, 2.3 Exterior Context Specific Requirements and 3.6 Interior Context Specific Requirements.

The design requirements of this manual apply to *temporary facilities*, as well as permanent *facilities*.

Exceptions: The requirements of the document, excluding sections 1.4 General Context Specific Requirements, 2.3 Exterior Context Specific Requirements and 3.6 Interior Context Specific Requirements do not apply to

- *service rooms*
- elevator machine rooms
- janitor rooms
- *service spaces*
- *crawl spaces*
- *attic or roof spaces*.

APPLICATION BASED ON FACILITY USE

The specific *facility* types listed in Sections 1.4 General Context Specific Requirements, 2.3 Exterior Context Specific Requirements and 3.6 Interior Context Specific Requirements shall comply with the provisions specified throughout the entire document, where applicable.

Where a *facility* contains more than one use covered by a special application section, each portion shall comply with the requirements for that section in addition to all other general provisions.

WORK AREAS AND EMPLOYEE-DESIGNATED AREAS

All *facilities* shall be *accessible* for employees, as well as patrons/users. All areas intended for use by employees shall be designed and constructed to comply with the design requirements of this manual, including access through doors into all offices.

RETROFITTING, ALTERATIONS AND ADDITIONS

Each *addition* to an existing *facility* shall be regarded as an *alteration*.

(Note: an alteration may or may not require further *MBC* upgrades).

Each *space* or *element* added to the existing *facility* shall comply with the applicable provision(s) of this manual.

Except where the provision of *accessible* features is *technically not feasible*, no *alteration* shall decrease or have the effect of decreasing accessibility or usability of an existing *facility* to below the requirements for new construction at the time of *alteration*.

If existing *elements*, *spaces* or common areas are altered, then each such altered *element/space/feature/area* shall comply with all applicable provisions.

If *alterations* of single *elements*, when considered together, amount

to an *alteration* of a room or *space* in a *facility*, the entire *space* shall be made *accessible*.

No *alteration* of an existing *element*, *space* or area of a *facility* shall impose a requirement for greater accessibility than that which would be required for new construction.

If an escalator or stairs are proposed as a means of access where none existed previously, and major structural modifications are necessary for such installations, then a means of *accessible* access shall also be provided.

If a planned *alteration* entails alterations to an *entrance*, and the *facility* has an *accessible entrance*, the *entrance* being altered is required to be *accessible*.

If the alteration work is limited solely to the electrical, mechanical or plumbing system, or to hazardous material abatement, or to automatic sprinkler *retrofitting*, and does not involve the alteration of any *elements* or *spaces* required to be *accessible* under these guidelines, then this manual does not apply (except for alarms, public telephones and assistive listening systems).

An *alteration* that affects the usability of or access to an area containing a primary function shall be made to ensure that, to the maximum extent feasible, the path of travel to the altered area, the washrooms, telephones and drinking fountains serving the

altered area are readily *accessible* to and usable by individuals with *disabilities*.

Where the provision of *accessible* features is *technically not feasible*, and the manual allows a reduction of maneuvering *space* from the requirements for new construction, the reduced dimensions are minimums. Where possible, larger maneuvering *spaces* must be provided.

EQUIVALENT FACILITATION

In a *retrofit* situation where the requirements of a section of this manual are *technically not feasible* to implement, equivalent facilitation may be proposed. Equivalent facilitation proposals shall be referred to the relevant member organization of the City of Winnipeg for review and approval on an individual basis. Refer also to 'Implementation and Enforcement' found in the document introduction.

ENVIRONMENTAL SUSTAINABILITY

The City of Winnipeg provides a vast range of environmental services to all Winnipeggers that are designed to protect and enhance the city's natural and built environment, including (but not limited to); climate change and air quality, urban energy, sustainable land development, sustainable transportation, solid waste and materials management, and

sustainable water and wastewater management.

Many of the City's environmental services and priorities are outlined in *Embracing Sustainability*, which was presented to Council in 2004. *Embracing Sustainability* reports on seventy three separate environmental initiatives, and builds on the policy foundation for environmental sustainability already established in *Plan Winnipeg 2020 Vision* and further articulated in *Sustainable Winnipeg* (a publication of the former Civic Environment Committee). It demonstrates that the City is an organization that provides a range of environmental services that are designed to protect and enhance Winnipeg's sustainability.

Many of the initiatives identified as key environmental priorities for the City are ongoing, and demonstrate a long-term commitment to the environment. Others are pilot projects or feasibility studies, intended to determine the effectiveness of specific environmental initiatives in the City's operations.

It is clear that environmental awareness is an increasingly important factor in the analysis and review of City initiatives. Each of the City's administrative reports now include a request for the environmental impact of the recommendation, placing environmental concerns alongside financial and human resource factors as key considerations.

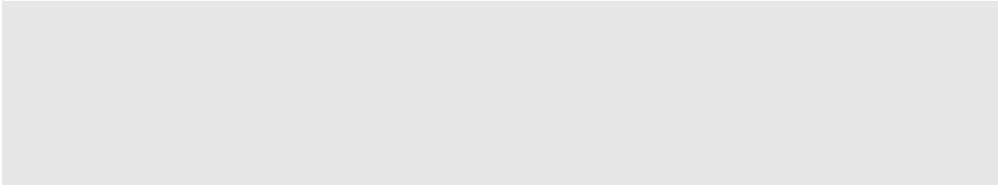

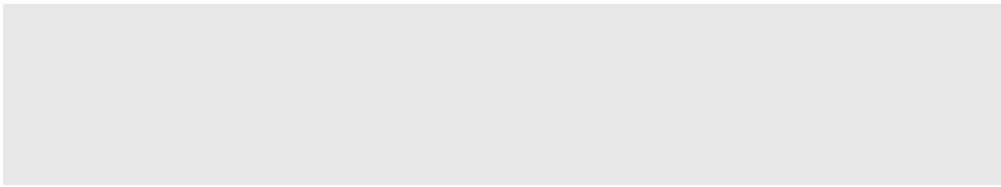

GENERAL STANDARDS

GENERAL STANDARDS

1.1.1 General Space and Reach Requirements

RATIONALE

The dimensions and maneuvering characteristics of wheelchairs and other mobility devices are as varied as the people who use them. Traditionally, accessibility standards have taken a conservative approach to wheelchair maneuverability, reflecting the needs of a physically strong individual using a manual wheelchair. Such an approach excludes the many users without such a degree of strength or using a larger mobility device. This manual more accurately reflects the vast array of equipment that is used by persons to access and use facilities, as well as the diverse range of user ability. This manual incorporates more generous *space* requirements, particularly related to the dynamic movement of people using wheelchairs, scooters or other assistive devices.

APPLICATION

Space and reach range provisions for persons who use wheelchairs, scooters and other mobility devices shall comply with this section.

DESIGN REQUIREMENTS

The *clear space* required for a wheelchair to make a 360-degree turn is 1830 mm (72 in.) in diameter as shown in Figure 1.1.1.3. For a scooter to make a 360-degree turn a *clear space* of 2440 mm (96 in.) diameter is required.

Although providing for the 360-degree scooter turning radius is preferred, the 360-degree wheelchair radius is acceptable.

The minimum *clear floor or ground space* required to accommodate a single, stationary wheelchair or scooter and occupant shall be 760 mm (30 in.) x 1370 mm (54 in.) as shown in Figures 1.1.1.6 and 1.1.1.7.

The minimum *clear floor or ground space* for wheelchairs or scooters may be positioned for forward or parallel approach to an object.

Clear space for wheelchairs may be part of the *knee space* required under some objects.

One full, unobstructed side of the *clear space* for a wheelchair or scooter shall adjoin or overlap an *accessible route* or adjoin another

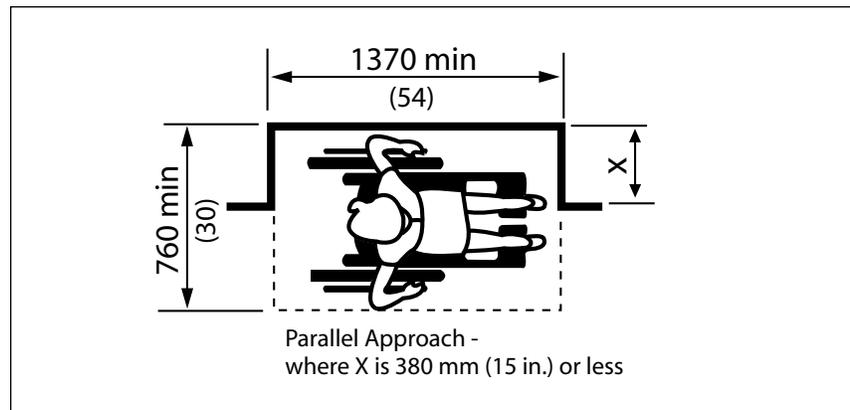

Figure 1.1.1.1 Wheelchair Clearances at Alcove

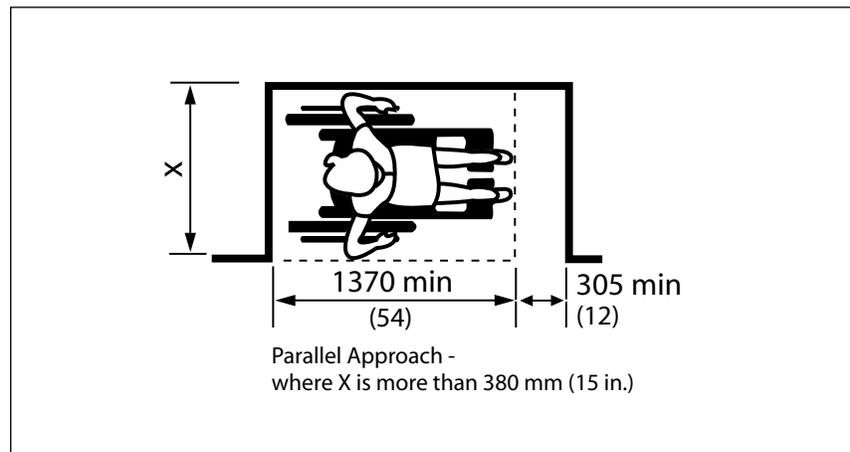

Figure 1.1.1.2 Wheelchair Clearances at Alcove

1.1.1 General Space and Reach Requirements (continued)

wheelchair *clear space*. If a *clear space* is located in an alcove or otherwise confined on all or part of three sides, additional maneuvering clearances shall be provided as shown in Figures 1.1.1.1, 1.1.1.2, 1.1.1.8 and 1.1.1.9.

The surface of *clear floor or ground spaces* for wheelchairs and scooters shall comply with Sections 2.1.1 Exterior Ground Surfaces and 3.1.1 Interior Floor Surfaces.

If the *clear space* only allows forward approach to an object, the maximum high forward reach allowed shall be 1200 mm (47 in.). The minimum low forward reach is 400 mm (15-3/4 in.). If the high forward reach is over an obstruction, reach and clearances

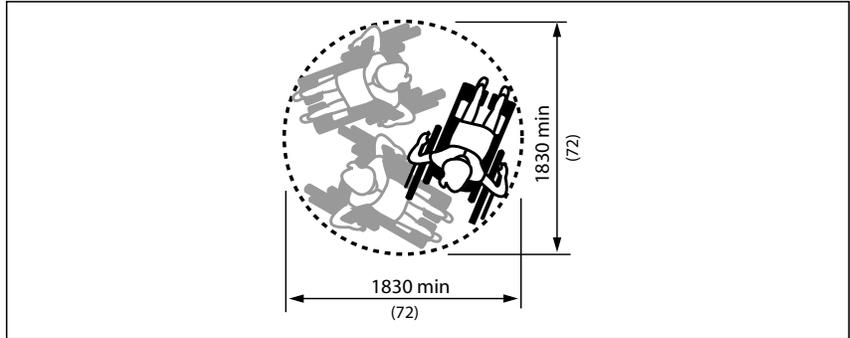

Figure 1.1.1.3 Wheelchair 360° Turning Space

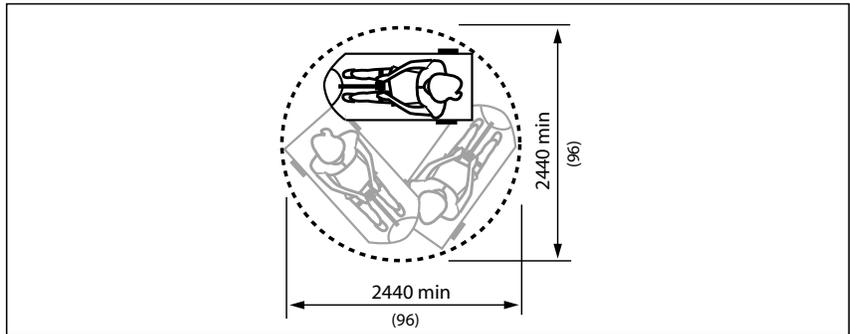

Figure 1.1.1.4 Scooter 360° Turning Space

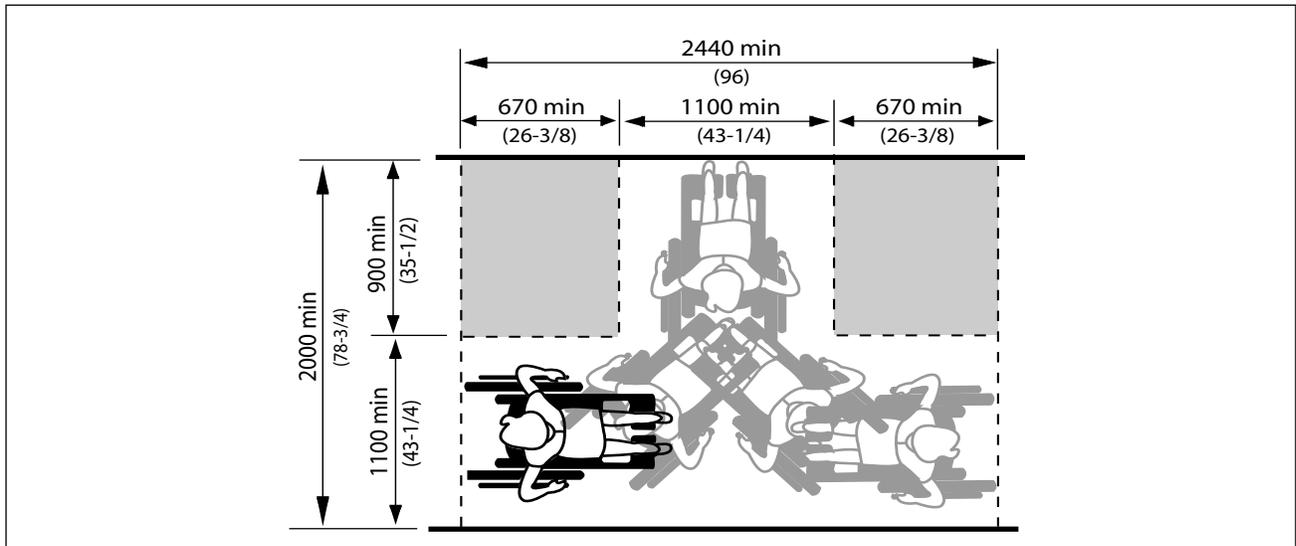

Figure 1.1.1.5 Wheelchair 180° Turning Space

1.1 GENERAL ACCESS AND CIRCULATION

GENERAL STANDARDS

1.1.1 General Space and Reach Requirements (continued)

shall be as shown in Figures 1.1.1.11 and 1.1.1.15.

If the *clear space* allows parallel approach to an object, the maximum high side reach allowed shall be 1370 mm (54 in.) and the low side reach no less than 230 mm (9 in.) above the floor. Refer to Figure 1.1.1.9. If the side reach is over an obstruction, the reach and clearances shall be as shown in Figure 1.1.1.9 and 1.1.1.10. Notwithstanding these requirements, all controls for the operation of *facility* services or safety devices, including electrical switches, thermostats and intercom switches, shall be mounted 850 mm (33-1/2 in.) to 1200 mm (47 in.) above the floor as per Section 3.5.1 Control and Operating Mechanisms.

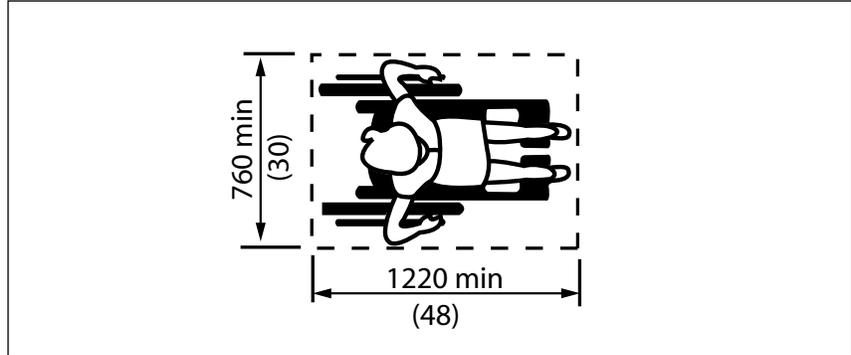

Figure 1.1.1.6 Clear space for Wheelchair

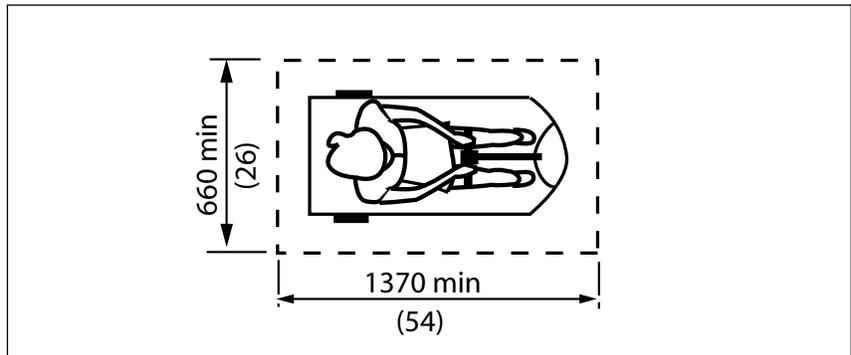

Figure 1.1.1.7 Clear space for Scooter

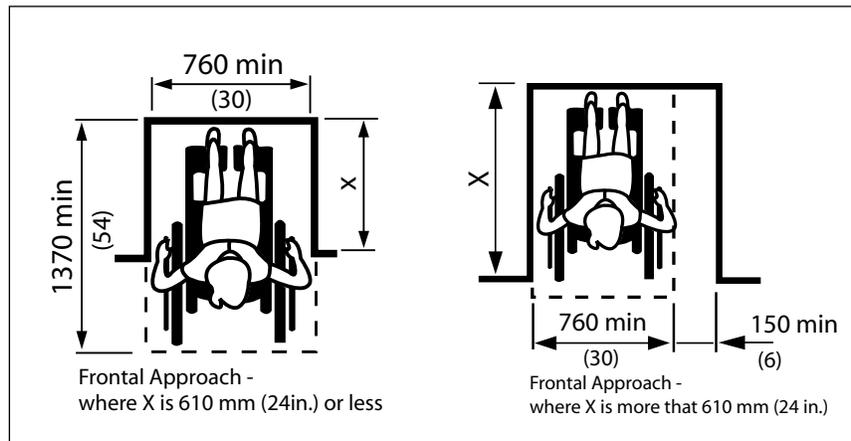
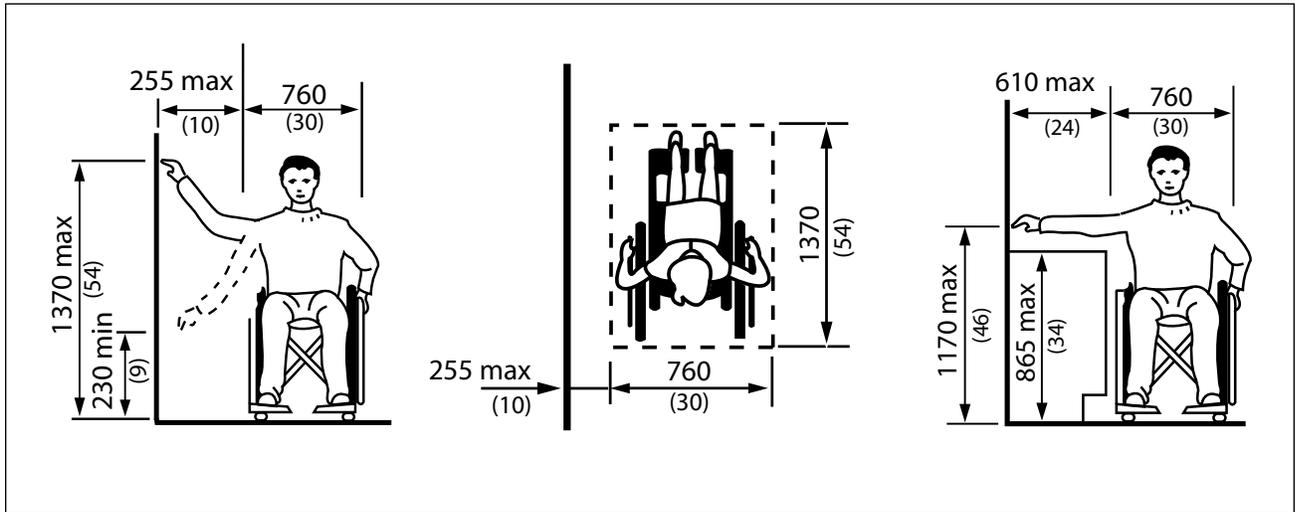
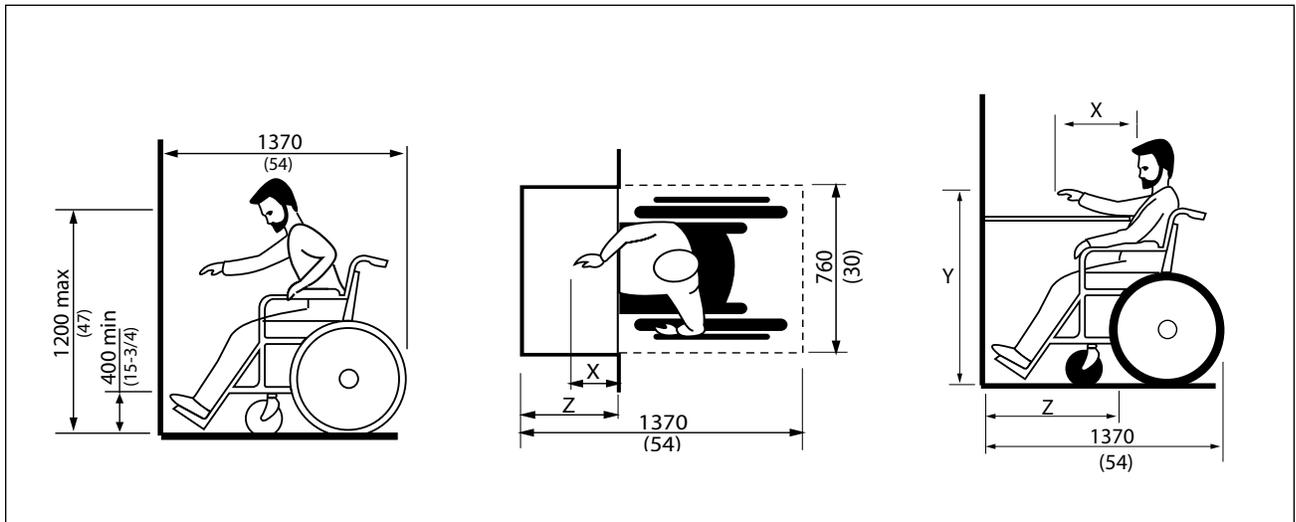

Figure 1.1.1.8 and 1.1.1.9 Wheelchair Clearances at Alcove

1.1.1 General Space and Reach Requirements (continued)



Figures 1.1.1.10, 1.1.1.11, 1.1.1.12 Wheelchair Side Reach Allowances, Maximum Distance to Wheelchair and Wheelchair Reach allowance over an Obstruction



Figures 1.1.1.13, 1.1.1.14, 1.1.1.15 Wheelchair Forward Reach Allowances and Forward Reach over an Obstruction

1.1 GENERAL ACCESS AND CIRCULATION

GENERAL STANDARDS

1.1.2 Protruding and Overhead Objects

RATIONALE

The creation of pathways free from protruding objects or free-standing obstacles is important to all *facility* users. An object protruding from a wall above the detection range of a cane is dangerous for an individual with a *vision impairment* or a pedestrian distracted by a conversation. The underside of stairways is a common overhead hazard. Temporary construction barriers can also be hazardous if their lower edge is too high to be detected by a person using a long white cane for mobility. Detectable surfaces around freestanding obstacles, such as light standards, are advantageous to anyone using a pathway.

APPLICATION

Protruding objects from a wall, ceiling or other location shall comply with this section.

DESIGN REQUIREMENTS

Objects protruding from walls with their outer edges between 680 mm (26-1/2 in.) and 2100 mm (82-3/4 in.) from the floor shall protrude not more than 100 mm (4 in.) into pedestrian areas, such as walkways, halls, corridors, passageways or aisles.

Objects attached to a wall with their outer edges at or below 680 mm (26-1/2 in.) from the floor may protrude any amount.

Objects that protrude more than 100 mm (4 in.) into pedestrian areas, such as walkways, halls, corridors, passageways or aisles, shall be identified with a *detectable warning* surface of at least 300 mm (11-3/4 in.) around the object, installed flush with the walkway surface or a guard protecting from accidental encroachment.

Freestanding objects shall not have any overhang of more than 300 mm (12 in.) between 680 mm (26-1/2 in.) and 2100 mm (82-3/4 in.) from the ground or floor.

The maximum height of the bottom edge of freestanding objects with a space of more than

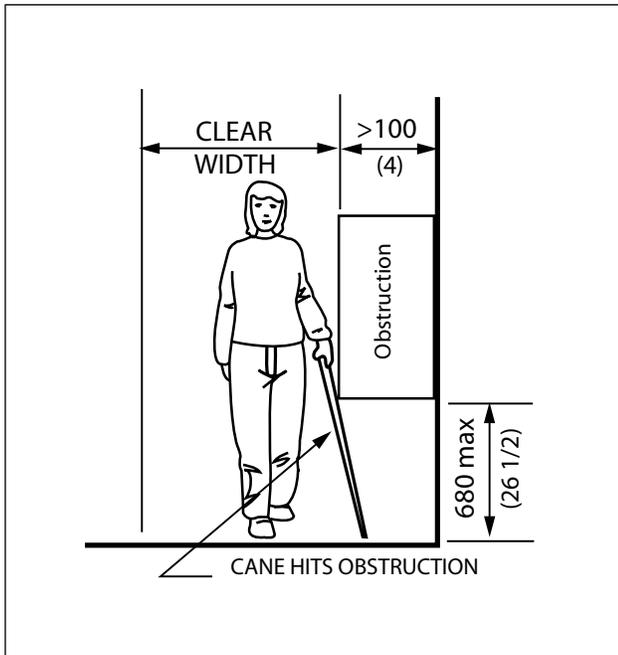

Figure 1.1.2.1 Limits of Protruding Objects

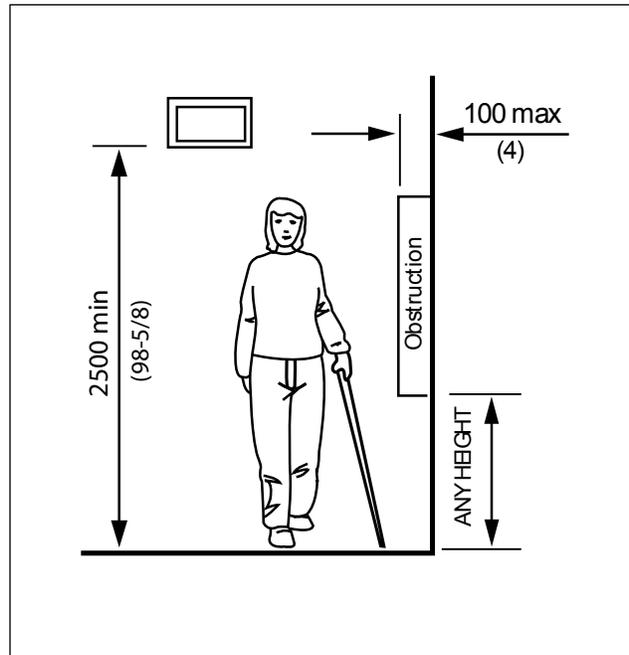

Figure 1.1.2.2 Limits of Protruding Objects

1.1.2 Protruding and Overhead Objects (continued)

300 mm (11-3/4 in.) between supports shall be 680 mm (26-1/2 in.) from the ground or floor.

Protruding objects shall not reduce the *clear* width required for an *accessible route* or maneuvering space.

The minimum *clear* headroom in pedestrian areas, such as walkways, halls, corridors, passageways, or aisles and along multi-use pathways, shall be a minimum of

- 2500 mm (98 1/2 in.) for items such as trees, awnings and business signs, etc.;
- 2400 mm for traffic signal heads; and
- 2100 mm (82-3/4 in.) for transit and traffic control signs.

A detectable *guard*: a guardrail or other barrier having its leading edge at or below 680 mm (26-1/2 in.) from the floor shall be provided where the headroom of an area adjoining an *accessible route* is reduced to less than 2500 mm (82-3/4 in.).

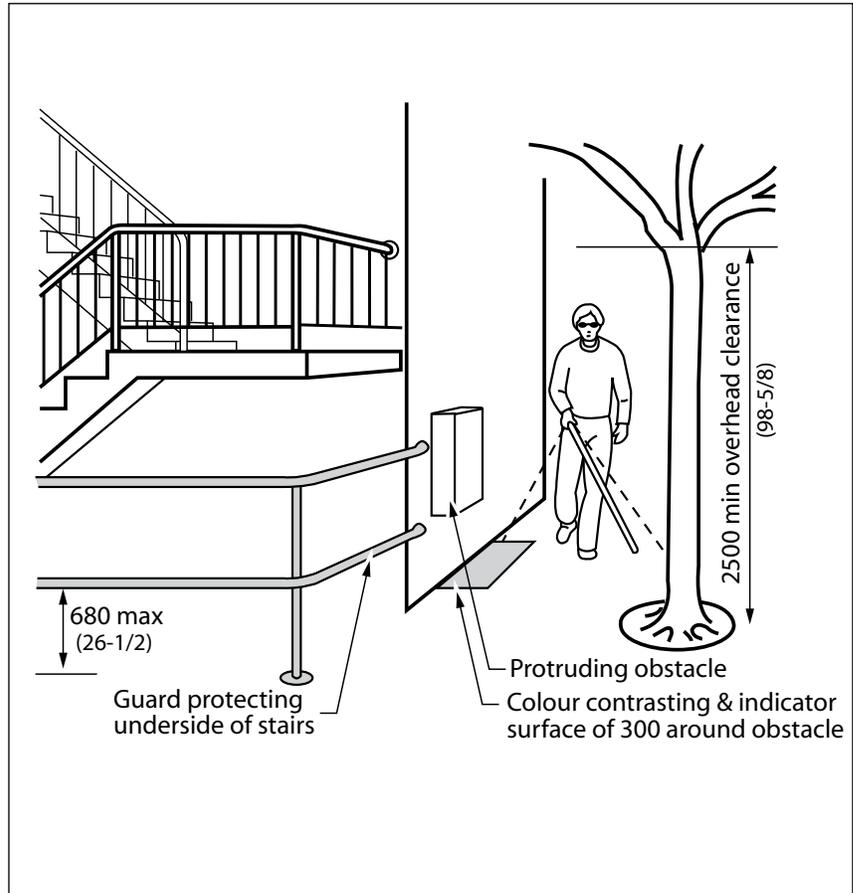

Figure 1.1.2.3 Overhead Obstructions

RELATED SECTIONS

- 1.1.3 Accessible Routes
Paths and Corridors
- 1.2.1 Texture, Finishes and
Colour
- 1.2.6 Detectable Warning
Systems
- 2.1.1 Exterior Ground Surfaces
- 2.1.3 Streetscape
- 2.2.2 Plantings
- 3.1.1 Interior Floor Surfaces

1.1 GENERAL ACCESS AND CIRCULATION

GENERAL STANDARDS

1.1.3 Accessible Routes, Paths and Corridors

RATIONALE

Accessible routes, paths and corridors are designed to reflect good *wayfinding* principles.

Tactile maps and/or recorded instructions can augment orientation cues and enable people to find their way throughout a *facility* independently, even in complex settings. A well-designed setting can be easy to understand and move through.

Routes of travel to and through a *facility* should address the full range of individuals that may use them. They must provide the *clear* width necessary for persons using wheelchairs or scooters, those pushing strollers, those with vision loss or those travelling in pairs. Consideration should be given both to the width of items, such as wheelchairs and scooters, and also their maneuverability. While a corridor may be wide enough for a person to drive a scooter in a straight line, it may not be possible to make a turn around a corner.

Gradual sloped walkways are the preferred means of changing level, rather than *ramps* or lifts.

Vertical elements such as public art, tree guards, benches, utility boxes or bike racks, should not infringe on the *clear* width of access routes, paths or corridors. Horizontal elements such as patterned coloured concrete or pavers shall be used as *delectors* and not within the *clear path*

of travel.

Minimum *clear* widths should be maintained when temporary barriers are erected around a construction *site*.

Strong *colour contrasts* and/or *tactile* pathways set into the edges of floors or sidewalks may be used to assist individuals with vision *impairments* to negotiate an environment. Edge protection that guards a change in level is an important safety feature for all users.

Covered routes are preferred in exterior locations, or alternatively the incorporation of snow-melting systems. Snow accumulation at routes should be removed completely after each snow fall.

APPLICATION

All routes, paths or corridors shall comply with this section.

At least one *accessible route* complying with this section shall be provided within the boundary of the *site* from *accessible* parking *spaces*, passenger loading zones (if provided), and public *streets* or sidewalks to the *accessible facility entrance* they serve. The *accessible route* shall, to the maximum extent feasible, coincide with the route for the general public.

At least one *accessible route* shall connect *accessible buildings, facilities, elements* and *spaces* that are on the same *site*. It is preferable to have all routes *accessible*.

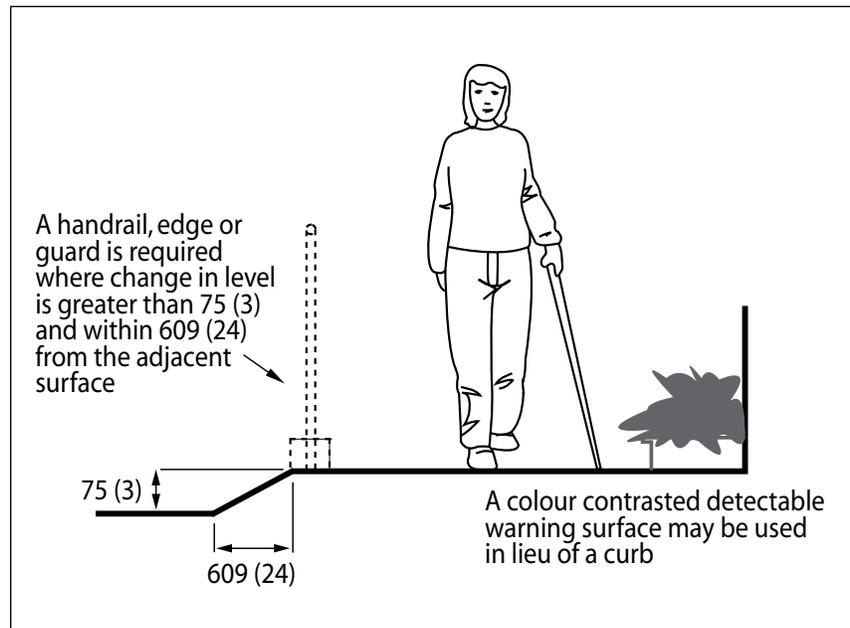

Figure 1.1.3.1 Edge Protection

1.1.3 Accessible Routes, Paths and Corridors (continued)

Accessible routes are permitted to include *ramps, curb ramps, stairs, elevators* or other elevating devices, as per Section 3.1.6 Platform Lifts, where there exists a difference in elevation.

Where a *facility* is on a sloped *site* and is accessible from *street* level at different floors, persons with *disabilities* shall not be required to travel outside to gain access to another floor.

Except where essential obstructions in a work area would make an *accessible route* hazardous, an *accessible route* shall connect *accessible entrances* with all *accessible spaces* and *elements* within the *facility*. An *accessible route* complying with this section shall be provided within all normally *occupiable* floor areas. It is not appropriate to have only some areas *accessible*.

Exceptions: The provision of an *accessible route* does not apply

- to *service rooms*;
- to elevator machine rooms;
- to janitor rooms;
- to *service spaces*;
- to *crawl spaces*;
- to *attic* or *roof spaces*;
- to high-hazard industrial occupancies;
- within portions of a floor area with fixed seats in an *assembly occupancy* where these portions are not part of an *accessible route* to *spaces* designated for wheelchair use; or
- within a suite of residential

occupancy.

DESIGN REQUIREMENTS

The minimum *clear* width of *accessible routes* shall be 1100 mm (43-1/4 in.) except

- for public exterior routes, it shall be 1500 mm (59 in.);
- walkways to buildings can be reduced to 1200 mm (47 in.);
- at *ramps* as per Section 1.1.5 Ramps;
- at doors as per Section 3.1.3 Doors;
- where additional maneuvering *space* is required at doorways;
- at U-turns around obstacles less than 1220 mm (48 in.) wide, it shall be 1220 mm (48 in.); and
- where *space* is required for

two wheelchairs to pass, it shall be 1830 mm (72 in.).

Every off-street *accessible route* less than 1830 mm (72 in.) wide shall be provided with an unobstructed passing *space* of not less than 1830 mm (72 in.) in width and 1830 mm (72 in.) in length, located not more than 30 meters (98 ft. 5 in.) apart.

Accessible routes shall

- have a longitudinal grade not steeper than 1:20 (5%); and
- have minimal *cross slope*, but never steeper than 1:50 (2%). Where *technically not feasible* to achieve 2%, maximum shall never exceed 1:30 (3.3%).

A *ramp* is required when an

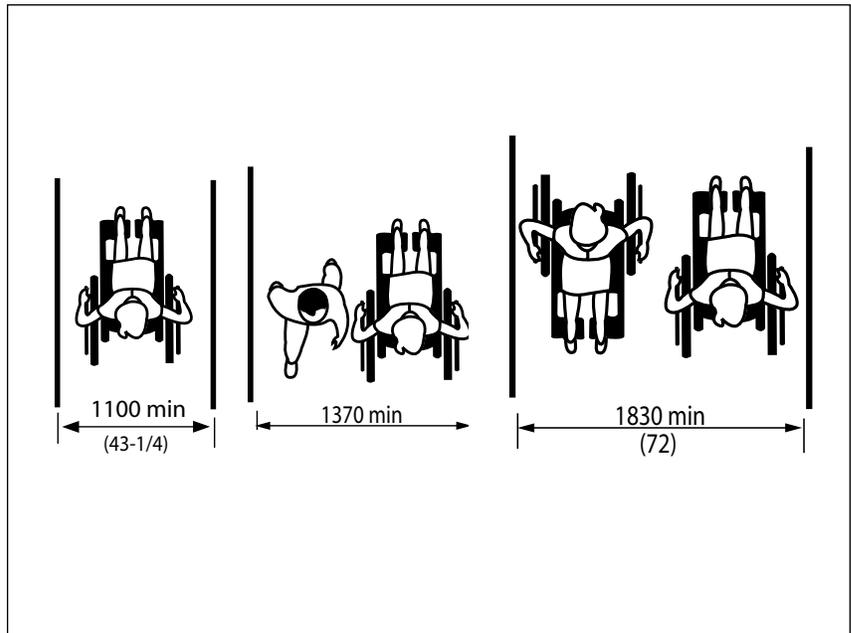

Figure 1.1.3.2 Recommended Minimum Access Widths

GENERAL STANDARDS

1.1.3 Accessible Routes, Paths and Corridors (continued)

accessible route, path or corridor has a longitudinal grade steeper than 1:20 (5%) in compliance with Section 1.1.5 Ramps.

Wall surfaces in corridors shall be non-abrasive below 2000 mm (78-3/4 in.)

Wherever possible, dead-end corridors should be avoided. Where dead-end corridors cannot be avoided, they shall be no greater than 6000 mm (19 ft.-8 in.) in length, and feature a 2440 mm (96 in.) diameter turn-around *space* at the end of the corridor.

Where the edges of *accessible routes* intersect with a vehicular route, they shall be separated from it by

- a curb with a *curb ramp*;
- a railing or barrier; and
- a *truncated dome detectable warning surface* in compliance with Section 1.2.6 Detectable Warning Systems.

Where the edges of *accessible routes*, paths or corridors (including elevated platforms, such as performance areas or loading docks) are more than 200 mm (7-7/8 in.) above an adjacent surface they shall be protected by

- a continuous *colour contrasting curb* at least 75 mm (3 in.) high; or
- by a continuous *truncated dome detectable warning surface* which is at least 600 mm (23-1/2 in.) wide and in compliance with Section 1.2.6 Detectable Warning Systems.

Note. This does not apply to sidewalks along roadways.

Where the drop-off along *accessible routes*, paths or corridors is more than 76 mm (3 in.) and within 610 mm (24 in.) from the adjacent surface the *accessible routes*, paths or corridors shall incorporate

- an 865 mm - 915 mm (34 in - 36 in.) high *handrail*

in compliance with 1.1.7 Handrails and Guards; or

- a *guard* which meets the requirements of the *MBC* and complies with 1.1.7 Handrails and Guards. Refer to Figure 1.1.3.1.

Protection from grade changes exceeding 75 mm (3 in.) along the edge of a sidewalk or walkway shall be provided by

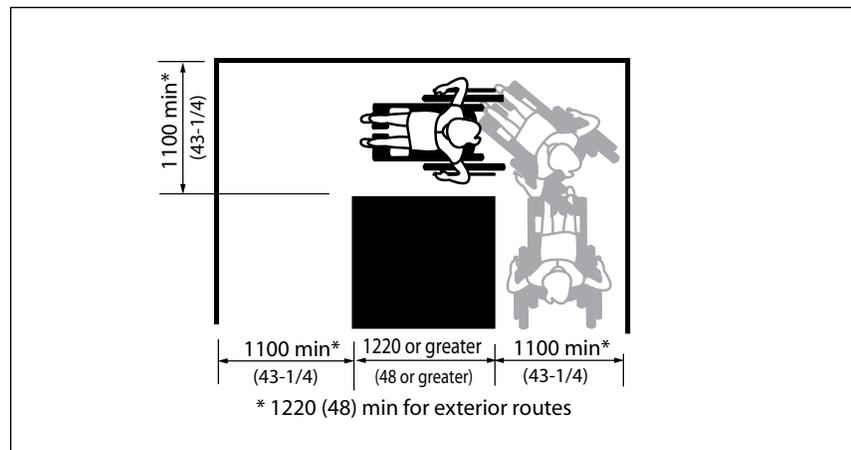

Figure 1.1.3.3 Turn around an Obstacle

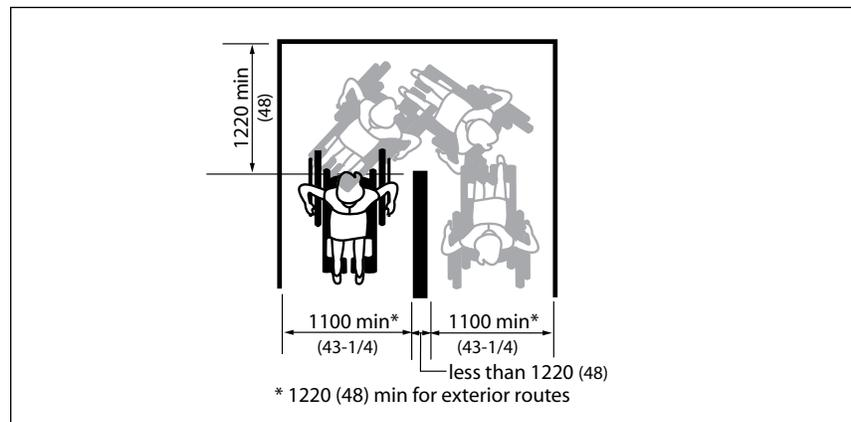

Figure 1.1.3.4 Turn around an Obstacle

1.1.3 Accessible Routes, Paths and Corridors (continued)

- a curb not less than 75 mm (3 in.) high; or
- a cane detectable railing or a barrier; or
- a median not less than 400 mm (16 in.) wide, constructed of a textured surface that contrasts from the walkway.

This does not apply to stairs or at elevated platforms such as performance areas or loading docks.

Accessible routes through off street parking lots shall not require people to pass behind parked vehicles unless the *accessible* route is separated from the parking space by a curb, railing or other barrier.

Where there is a change in direction along an *accessible route* and the intended destination of the route is not evident, directional *signage* shall be provided.

All portions of *accessible routes* shall be equipped to provide a level of illumination of at least 50 lux (4.6 ft-candles). Exception: Outdoor *park* settings where routes are not normally illuminated.

Provide designated areas for snow piling from all major exterior routes, away from pedestrian routes.

All *accessible routes* shall incorporate level rest areas that are a maximum of 30 meters (98.5 ft.) apart.

Benches shall be spaced no more than 300 meters - 400 meters

(985 ft - 1312 ft.) apart and be in compliance with Section 1.3.6 Benches.

Street construction can pose a hazard for persons with disabilities, particularly those who are blind or have some level of vision impairment. Extra precautions shall be used to ensure construction barricades do not pose additional hazards.

Where temporary construction intervenes along *accessible* routes, paths or corridors the minimum unobstructed width requirements for pedestrian travel remain a minimum of 1100 mm (43-1/4 in.) for interior routes and 1220 mm (48 in.) for exterior routes.

Alternative *accessible* safe crossings shall be provided where existing construction works obstruct curb ramps.

Where construction barricades are located along *accessible* routes, paths and corridors they must be cane detectable. An orange construction cone placed beneath barricades shall suffice. Refer to Section 1.1.2 Protruding and Overhead Objects for cane detection requirements.

RELATED SECTIONS

- 1.1.5 Ramps
- 1.1.7 Handrails and Guards
- 1.2.1 Texture, Finishes and
- 1.2.4 Signage
- 1.2.6 Detectable Warning Systems
- 1.3.4 Elevated Areas and

- Platforms
- 1.3.6 Benches
- 2.1.1 Exterior Ground Surfaces
- 2.1.3 Streetscape
- 2.1.2 Exterior Lighting
- 3.1.1 Interior Floor Surfaces
- 3.5.3 Interior Lighting
- 3.5.4 Interior Glare and Light Sources

GENERAL STANDARDS

1.1.4 Gates, Turnstiles and Openings

RATIONALE

Gates and turnstiles should address the full range of users that may pass through them. Single-bar gates designed to be at a convenient waist height for ambulatory persons are at neck and face height for children and persons who use wheelchairs or scooters.

Revolving turnstiles are a physical impossibility for a person in a wheelchair to negotiate. They are also difficult for persons using canes or crutches, or persons with poor balance. An adjacent opening of an appropriate width is essential for wheelchair access, as well as access for those using other mobility devices, strollers, walkers or delivery carts.

APPLICATION

Gates, turnstiles and openings shall comply with this section.

DESIGN REQUIREMENTS

Where gates or openings are provided through fences or screens to *public use* areas, such openings shall be *accessible* (i.e., a minimum of 915 mm (36 in.) wide, to allow free passage of a person in a wheelchair. Hardware should be suitable for autonomous use, and any closing device should not be spring-loaded).

Where turnstiles or other ticketing control devices which are not wheelchair *accessible* are utilized,

then a gate or opening which is *accessible* shall also be provided in the same location.

Turnstiles shall incorporate a pronounced *colour contrast*, to differentiate them from the surrounding environment.

Where gates are incorporated into a chain-link fencing system, the poles at either side of the gate shall incorporate a pronounced *colour contrast* from the fence and the surrounding environment.

RELATED SECTIONS

- 1.1.1 Space and Reach Requirements
- 1.2.4 Signage
- 1.2.5 Information Systems
- 3.1.3 Doors
- 3.1.4 Windows, Glazed Screens and Sidelights
- 3.5.1 Controls and Operating Mechanisms
- 3.5.2 Card Access, Safety and Security Systems

1.1.4 Gates, Turnstiles and Openings (continued)

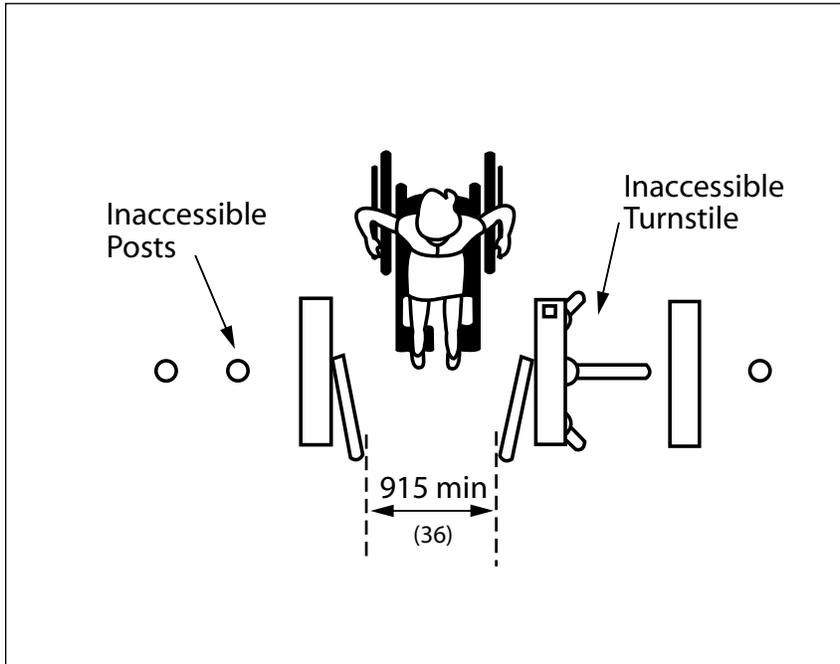

Figure 1.1.4.1 Wheelchair Access at Turnstile

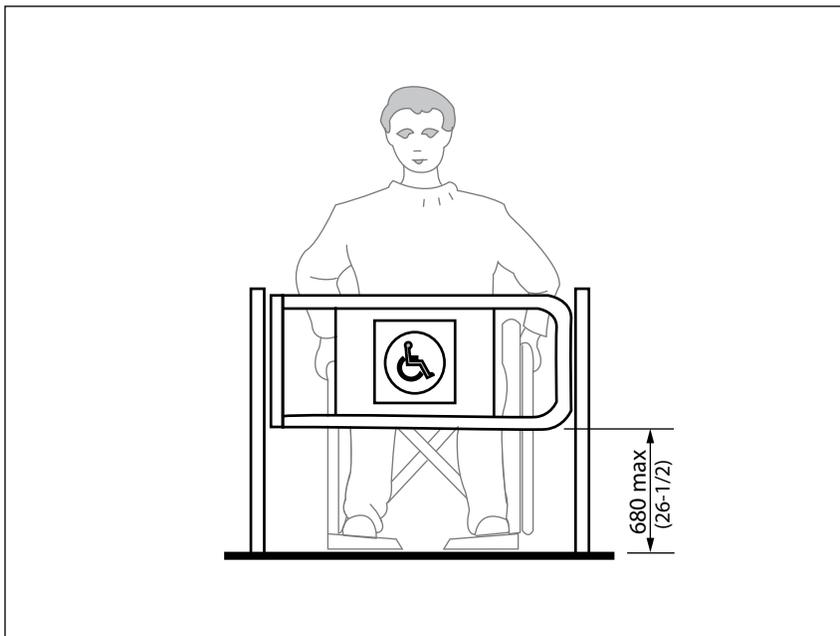

Figure 1.1.4.2 Wheelchair Access at Turnstile

1.1 GENERAL ACCESS AND CIRCULATION

GENERAL STANDARDS

1.1.5 Ramps

RATIONALE

Where a change in level already exists or cannot be avoided, a properly designed *ramp* can provide access for those using wheelchairs, pushing strollers or moving packages on a trolley.

The design of the *ramp* is critical to its usefulness and safety. A steeply inclined *ramp* is difficult to ascend when using a wheelchair, and can increase the risk of the wheelchair tipping backwards. Descending a steep *ramp* can also be hazardous. Any *cross slope* will further increase the effort required to negotiate the *ramp*. Maneuvering *space* at the top and bottom are other important factors in a *ramps* usability. Level areas at points along a long *ramp* enable an individual to rest.

Curved *ramps* are not recommended.

Textured surfaces, edge protection and *handrails* all provide important safety functions.

Covered *ramps* are preferred in exterior locations, or alternatively the incorporation of snow-melting systems. Snow accumulation at *ramps* should be removed completely after each snow fall.

APPLICATION

Where the slope of an accessible route is less than 1:20 (5%) there is no requirement for it to be designed as a *ramp*.

Any part of an *accessible route* with a slope steeper than 1:20 (5%) shall be considered a *ramp* and shall comply with this section.

DESIGN REQUIREMENTS

Accessible ramps shall be on an *accessible route* complying with Section 1.1.3 Accessible Routes, Paths and Corridors.

The surfaces of ramps and landings shall

- have a surface that is slip resistant;
- have a *colour contrast* to demarcate the leading edge of the landing, as well as the beginning and end of a ramp.

The *ramp slope* shall be between 1:15 (6.7%) and 1:20 (5%). In a *retrofit* situation where it is *technically not feasible* to provide a *ramp* with a *ramp slope* between 1:15 (6.7%) and 1:20 (5%), a *ramp slope* not steeper than 1:12 (8.3%) may be used. However, more gradual slopes are preferred.

Ramps shall have level landings at the top and bottom of each run and also where the *ramp* changes direction.

The maximum horizontal length between landings shall not exceed 9 m (29 ft. - 6 in.).

Landings shall

- be at least as wide as the

- widest *ramp* run leading to it;
- have a minimum size not less than 2440 x 2440 mm (96 x 96 in.) if located at the top or bottom of a *ramp* or if served by a doorway. (In a *retrofit* situation where creating a suitably sized landing is *technically not feasible*, the required landing size may be reduced to 1670 x 1670 mm. (65-3/4 x 65-3/4 in.);
- on an intermediate landing of a U-shaped *ramp* have a length not less than 1670 mm (65-3/4 in.) and a width not less than 2440 mm (96 in.) as per Figure 1.1.5. In a *retrofit* situation where creating a suitably sized landing is *technically not feasible*, the required landing width may be reduced to 2120 mm (84in);
- on an intermediate landing at the corner of an L-shaped *ramp* have a length and width not less than 1670 mm (65-3/4 in.) as per Figure 1.1.5.1; and
- on an intermediate landing at a straight *ramp* have a length not less than 1670 mm (65-3/4 in.) as per Figure 1.1.5.1.

Outdoor *ramps* and their approaches shall be designed so that water will not accumulate on walking surfaces.

Provide dedicated area for snow piling from all exterior *ramps*, away from pedestrian routes.

Edges of *ramps* and landings shall be protected with a wall or *guard* on all sides as per Section

1.1.5 Ramps (continued)

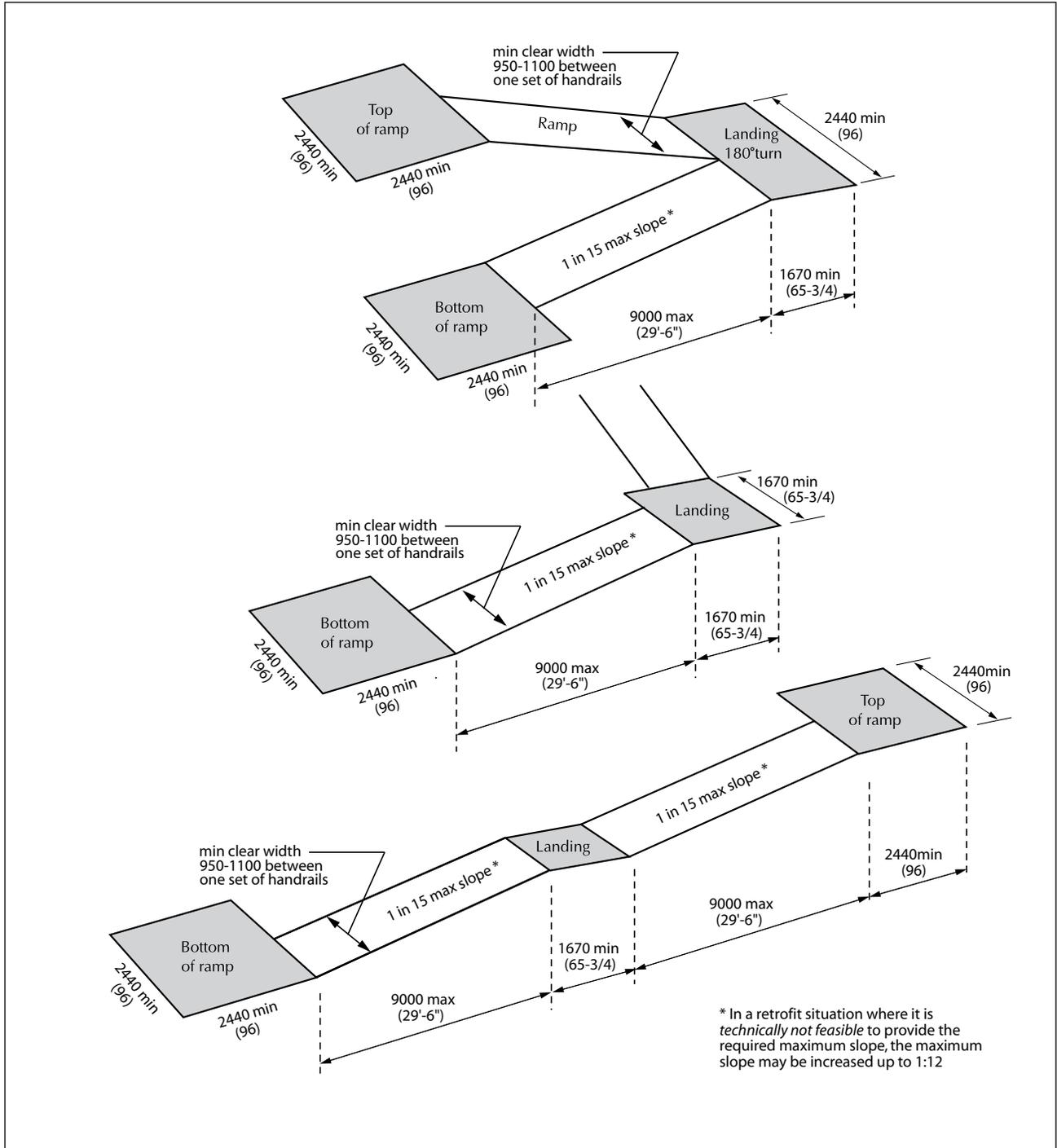

Figure 1.1.5.1 Minimum Ramp Landing Dimensions

GENERAL STANDARDS

1.1.5 Ramps (continued)

1.1.7 Handrails and Guards.

A ramp run with a rise greater than 150 mm (6 in.) shall have two sets of *handrails* which

- are on both sides;
- have a width between at least one set of *handrails* of 950 - 1100 mm (37-1/2 in - 43-1/4 in.);
- comply with Section 1.1.7 Handrails and Guards;
- are continuous on the inside of a ramp incorporating a change in direction U-shaped or L-shaped ramps;
- when not continuous, extend horizontally at least 300 mm (12 in.) beyond the top and bottom of the ramp and return to the wall, floor, or post;
- for the first *handrail*, is located between 865 mm (34 in.) and 965 mm (38 in.) from the ramp surface to the top of the *handrail*; and
- for the second *handrail*, is located 690 mm (27 in.) maximum from the ramp surface to the top of the *handrail*.
- include spacing between the top and bottom *handrail* of 230 mm (9 in.) minimum.

EXCEPTION: Where a ramp serves as an aisleway for fixed seating, the requirements for

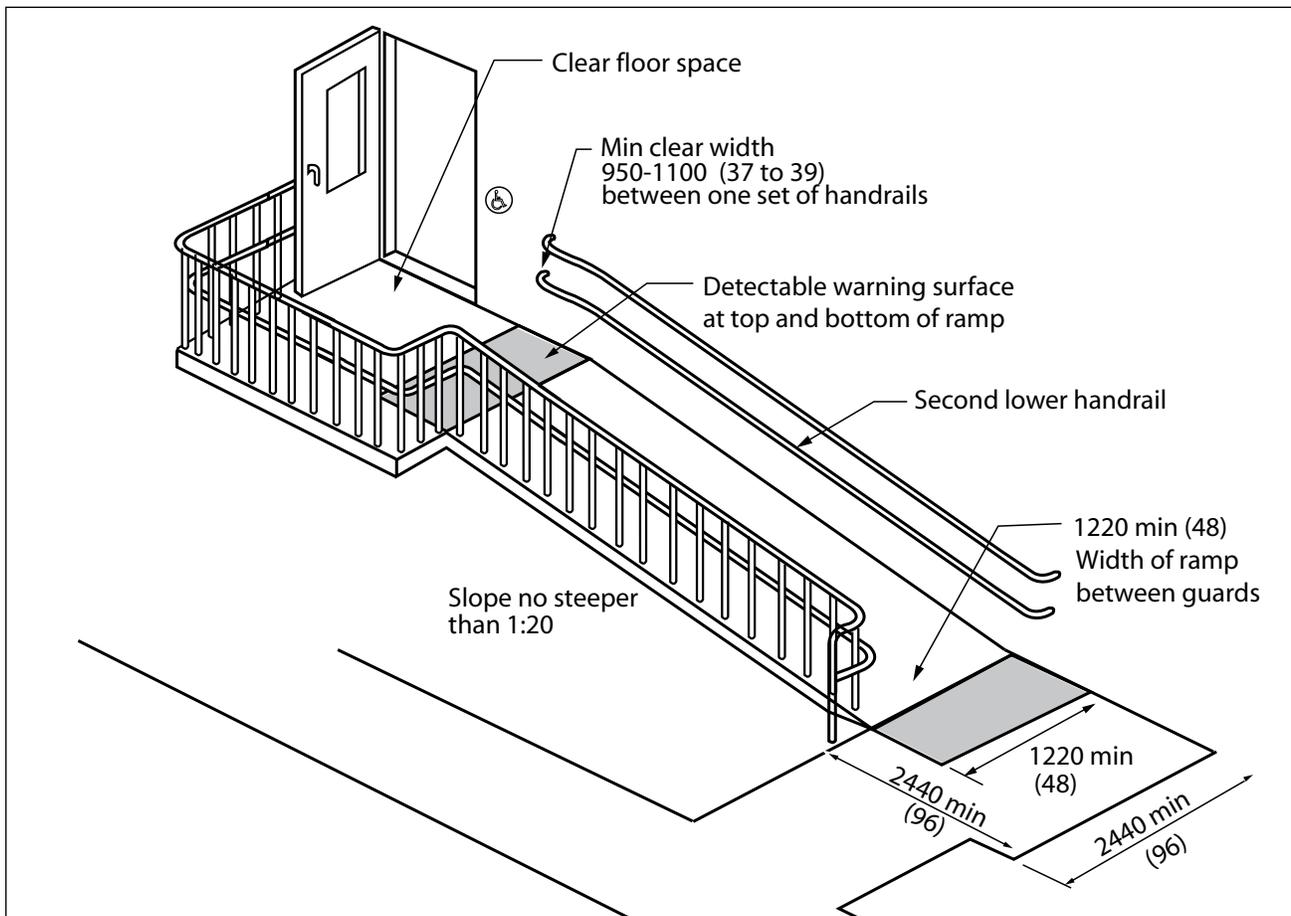

Figure 1.1.5.2 Ramp Criteria, for Maneuvering Space at Doors Refer to Figures 3.1.3.6 and 3.1.3.7

1.1.5 Ramps (continued)

ramp handrails do not apply.

Ramps shall incorporate *detectable warning* surfaces in compliance with Section 1.2.6 Detectable Warning Surfaces.

RELATED SECTIONS

- 1.1.1 Space and Reach Requirements
- 1.1.7 Handrails and Guards
- 1.2.4 Signage
- 1.2.6 Detectable Warning Surfaces
- 2.1.1 Exterior Ground Surfaces
- 2.1.2 Exterior Lighting
- 2.1.3 Streetscape
- 2.1.5 Curb Ramps and Truncated Dome Detectable Warning Surfaces
- 3.1.1 Interior Floor Surfaces
- 3.1.3 Doors
- 3.5.3 Interior Lighting
- 3.5.4 Interior Glare and Light Sources

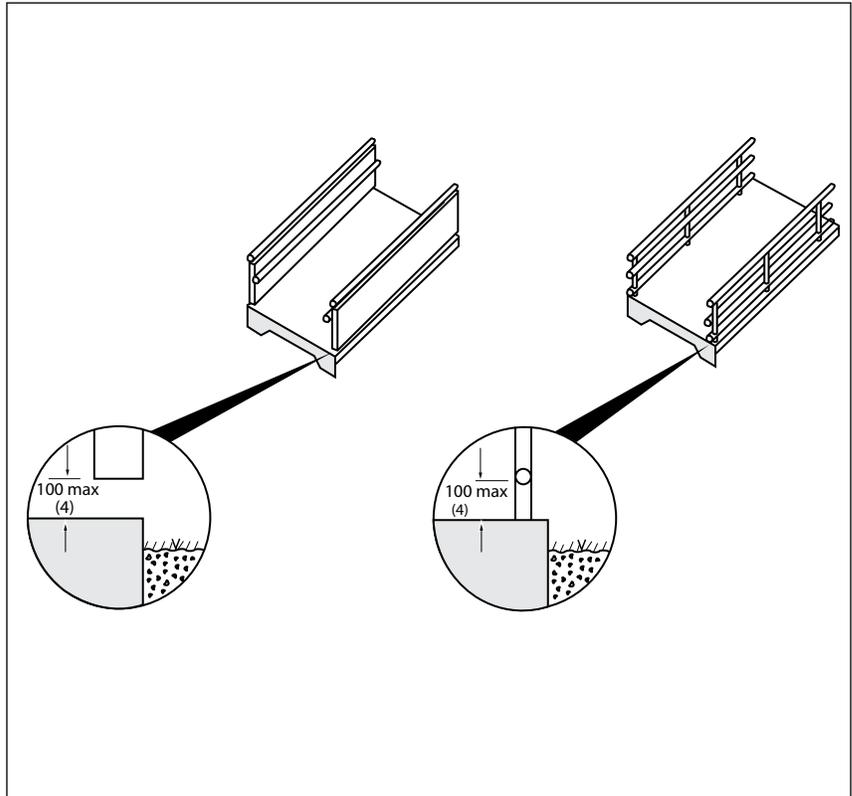

Figure 1.1.5.3 Edge Protection at Ramps

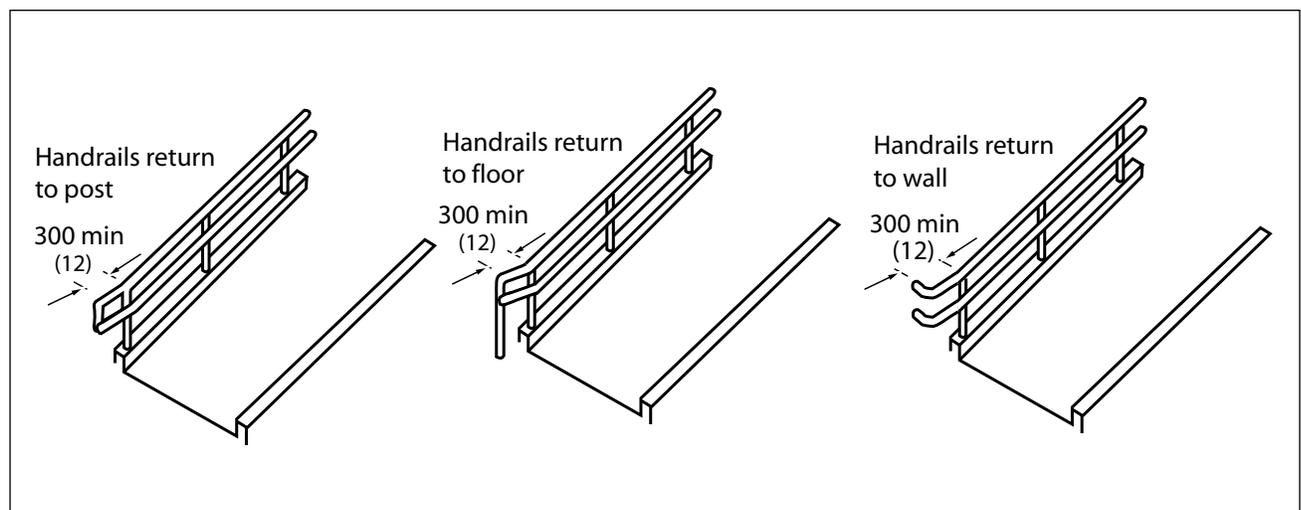

Figure 1.1.5.4 Horizontal *Handrail* Extensions

1.1 GENERAL ACCESS AND CIRCULATION

GENERAL STANDARDS

1.1.6 Stairs

RATIONALE

Covered stairs are preferred in exterior locations. Snow accumulation at stairs should be removed completely after each snow fall.

Poorly designed stair nosings are a tripping hazard, particularly to persons with prosthetic devices or those using canes. Cues to warn individuals with vision *impairments* of an upcoming set of stairs are important, as are *colour contrasting edges* on treads. Patterned surfaces on stairs obscure edges which can be a hazard.

APPLICATION

Interior and exterior stairs shall comply with this section.

In a *retrofit* situation, dimensional changes to steps and landings are not required. All other design requirements must be met.

DESIGN REQUIREMENTS

The surfaces of landings and treads shall

- have a surface that is slip resistant;
- have a colour and texture contrast to demarcate the leading edge of the tread, the leading edge of the riser nosing, and the leading edge of the landing, as well as the beginning and end of a ramp; and
- the horizontal and vertical surfaces of the stair nosing shall have a colour and texture

contrasting from the remainder of the riser and tread.

A flight of stairs shall have

- uniform riser heights and tread depths;
- risers not more than 180 mm (7 in.) and not less than 125 mm (5 in.) high;
- run not less than 280 mm (11 in.) and not more than 355 mm (14 in.) deep, measured from riser to riser; and
- no open risers.

Nosings shall

- project not more than 25 mm (1 in.);
- have no abrupt undersides;
- have a curved or bevelled leading edge of the tread between 6 mm (1/4 in.) and 10 mm (3/8 in.);
- where projecting, be sloped to the riser at an angle not less than 60 degrees to the horizontal;
- be illuminated to a level of at least 100 lux (9.2 ft-candles);
- be slip-resistant; and
- have the horizontal and vertical surface of the stair nosing in 70% *colour contrast* with the remainder of the riser and tread.

Stairs shall incorporate *detectable warning* surfaces that

- are illuminated to a level of at least 100 lux (9.2 ft-candles). Exterior lighting levels on stairs can be reduced slightly;

- are *colour contrasted* with the adjacent flooring material; and
- comply with Section 1.2.6 Detectable Warning Systems.

Stairs shall incorporate two sets of *handrails* which shall

- comply with Section 1.1.7 Handrails and Guards;
- be installed on both sides;
- for the first *handrail*, be of uniform height, located between 865 mm (34 in.) and 965 mm (38 in.) from the stair nosing;
- for the second *handrail*, be of uniform height located 690 mm (27 in.) maximum from the stair nosing
- include spacing between the two *handrails* of at least 230 mm (9 in.);
- have a continuous inside *handrail* on change of direction stairs; and

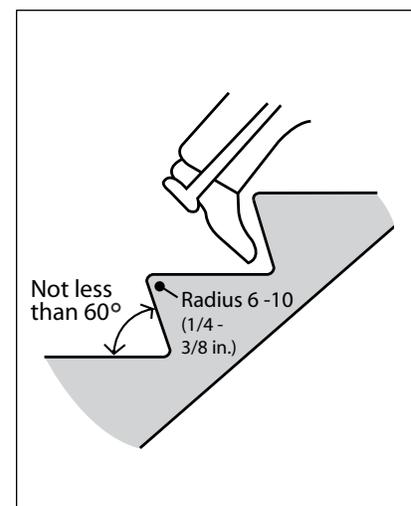

Figure 1.1.6.1 Raked Riser

1.1.6 Stairs (continued)

- where not continuous
- extend at the bottom of the stairs for a distance of one tread depth beyond the first riser, then horizontally not less than 300 mm (11-3/4 in.), at a height ranging between 865 mm (34 in.) and 920 mm (36 in.) above the floor
- extend horizontally at the top of the stairs not less than 300 mm (11-3/4 in.), at a height ranging between 865 mm (34 in.) and 920 mm (36 in.) above the floor; and
- return to the wall, or post in a manner that will not obstruct pedestrian travel or create a hazard.

Provide dedicated area for snow piling from all exterior stairs, away from pedestrian routes.

RELATED SECTIONS

- 1.1.7 Handrails and Guards
- 1.2.1 Texture, Finishes and Colour
- 1.2.4 Signage
- 1.2.6 Detectable Warning Surfaces
- 2.1.1 Exterior Ground Surfaces
- 2.1.2 Exterior Lighting
- 3.1.1 Interior Floor Surfaces
- 3.5.3 Interior Lighting
- 3.5.4 Interior Glare and Light Sources

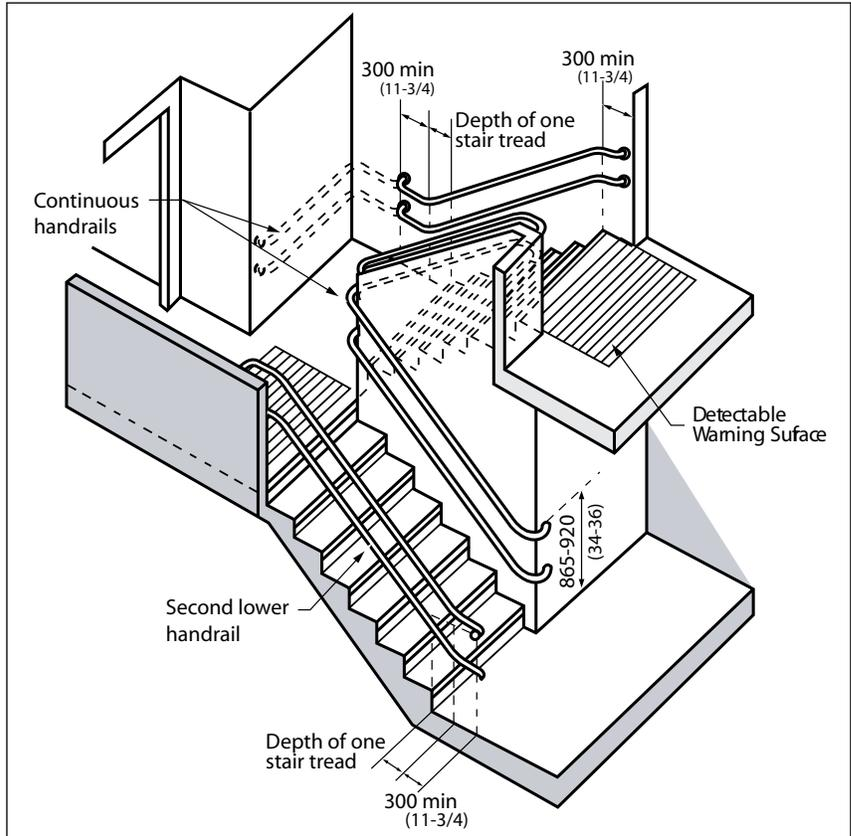

Figure 1.1.6.2 Stair Design Criteria

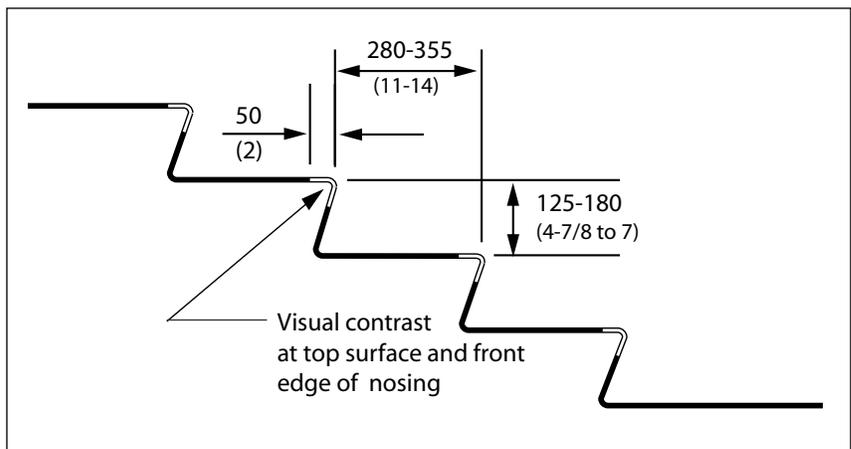

Figure 1.1.6.3 Stair Tread Criteria

GENERAL STANDARDS

1.1.7 Handrails and Guards

RATIONALE

In the design of *handrails*, consideration must be given to the range of hands that will grasp them. A *handrail* profile should be graspable by an adult as well as a child or a person with arthritis. The same is true for the heights of *handrails*.

Extensions of the *handrails* at the top and bottom of stairs, along with the use of a contrasting colour, provide important cues for a visually impaired individual, and provide a support to ensure a safe and stable gait before ascending or descending the stairs. A continuous *handrail* with no interruptions ensures that a handhold will not be broken.

The *clear space* between the wall and *handrail* is also essential, as it must provide a *clear* area for the hand and knuckles but must not offer *space* into which the arm may slip during a fall or stumble on the stairs.

Guards provide a protective barrier around an opening in a floor, balcony, or mezzanine and along *accessible* routes, paths or corridors. Guards prevent a fall to a lower level and can block entry into dangerous areas.

APPLICATION

Handrails or *guards* are required anywhere where there is a grade drop off 75 mm (3 in.) or greater within 609 mm (24 in.) from any walking surface edge as per

Figure 1.1.3.1.

DESIGN REQUIREMENTS

For *ramps* and stairs dual height *handrails* are required. Refer to Sections 1.1.5 Ramps and 1.1.6 Stairs.

Handrails shall

- have a circular section 30 mm - 43 mm (1-3/16 in. – 1-11/16 in.) in diameter. Any non-circular shape, with a graspable portion that has a perimeter not less than 100 mm (4 in.) and not more than 125 mm (5 in.) whose largest cross-sectional dimension is not more than 45 mm (1-3/4 in.);
- be free of any sharp or abrasive *elements*;
- have continuous gripping surfaces, without interruption by newel posts, other construction *elements*, or obstructions that can break a handhold;
- have a *clear space* between the *handrail* and the wall of
 - at most 60 mm (2 3/8 in.); or
 - 60 mm (2 3/8 in.) where the wall has a rough surface;
- be terminated in a manner that will not obstruct pedestrian travel or create a hazard; and
- where leading to a hazardous location, optionally incorporate a textured finish for a distance of at least 600 mm (23 1/2 in.) from the hazard.

A recess containing a *handrail* shall extend at least 450 mm (17 3/4 in.) above the top of the rail.

The height of a set of *handrails* shall be

- for the first *handrail*, located between 865 mm (34 in.) and 965 mm (38 in.) from the *ramp* surface to the top of the *handrail*; and
- for the second *handrail*, located 690 mm (27 in.) maximum from the *ramp* surface to the top of the *handrail*.
- spaced a minimum of 230 mm (9 in.) between the top and bottom *handrail*.

Handrails and their supports shall be designed and constructed to withstand the loading values obtained from the non concurrent application of

- a concentrated load of not less than 0.9 kN (200 lb.) applied at any point and in any direction; and
- a uniform load of not less than 0.7 kN/m (47 lb./ft.) applied in any direction to the *handrail*.

Handrails shall incorporate a pronounced *colour contrast*, to differentiate them from the surrounding environment.

Where a *guard* is provided, it shall

- be a minimum of 150 mm (5-3/4 in.) high in order to be cane detectable and to act as a safeguard for wheelchair users;

1.1.7 Handrails and Guards (continued)

- comply with the requirements of the *MBC*.

RELATED SECTIONS

- 1.1.1 Space and Reach Requirements
- 1.1.3 Accessible Routes, Paths and Corridors
- 1.1.5 Ramps
- 1.1.6 Stairs
- 1.2.1 Texture, Finishes and Colour

Note: Two heights of handrails are required as Sections 1.1.5 and 1.1.6.

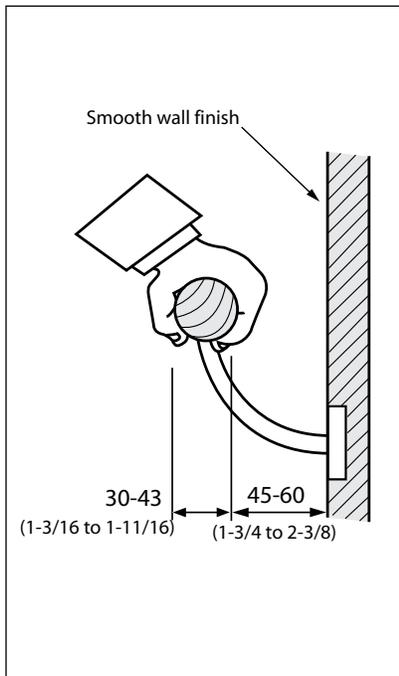

Figure 1.1.7.1 Handrail at Smooth Wall

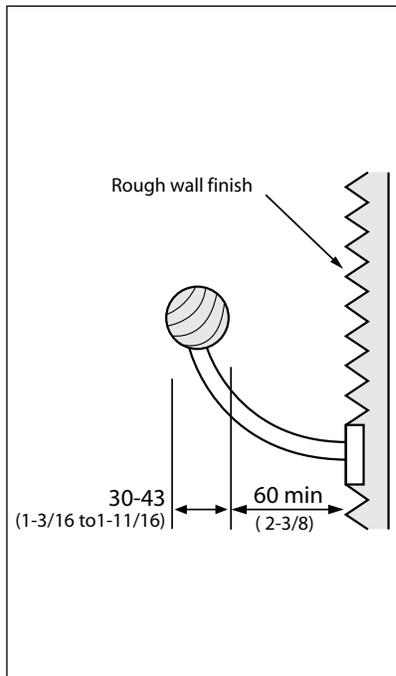

Figure 1.1.7.2 Handrail at Rough Wall

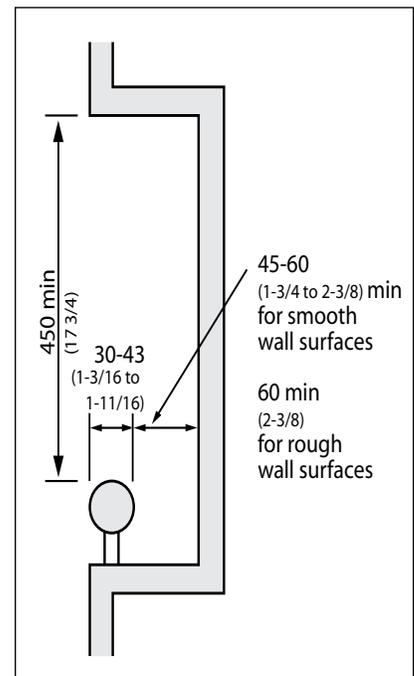

Figure 1.1.7.3 Handrail in Recess

1.1 GENERAL ACCESS AND CIRCULATION

GENERAL STANDARDS

1.2.1 Texture, Finishes and Colour

RATIONALE

The ability of an individual with a visual *impairment* to navigate an environment can be promoted through the strategic use of colour and texture.

Caution is recommended in the selection of heavy or distinct patterns on walking paths, walls or floors, since these can add visual confusion to settings for persons with low vision. Simple, repetitive, non-directional patterns that feature monochromatic or low *colour contrast* are preferred. Changes in material or texture should not necessitate a threshold.

Generally, for seniors and persons with low vision, colours in the warm end of the spectrum (yellow, orange, bright red, etc.) are easier to recognize as a delineator than those at the cool end of the spectrum.

APPLICATION

Textural and colour systems shall be used to enhance accessibility and shall comply with this section.

DESIGN REQUIREMENTS

Colour schemes shall incorporate a pronounced *colour contrast*, to differentiate boundaries of objects, distinguish objects from their background, and to generally enhance spatial orientation.

Signs shall incorporate pronounced glare-free *colour con-*

trast. A minimum colour/brightness contrast of 70% light reflectance is required. For signs, the most visible colours are white or yellow on a black, charcoal or other dark background, such as brown, dark blue, dark green or purple. Black lettering on white is also acceptable, although less readable than the reverse. Unacceptable background colours are light grey and pastel colours. Red lettering on a black background is also unacceptable.

Colour contrast shall be used as a safety measure to define edges or boundaries of objects (e.g., stair nosings, doors, *handrails*, etc.). Colour or tone shall be used to visually define the boundaries of a room (i.e., where the wall meets the floor). Baseboards in monochromatic environments shall be highly contrasting with the wall and floor colours, to provide boundary definition.

Colour shall be used consistently to visually identify distinctive objects (e.g., exit doors).

Either bright colours or a highly contrasting tone shall be used to assist with *wayfinding*. (e.g. If used as part of a *signage* band located on walls at eye level, this band is easier to follow than monolithic wall colouring, and can be the visual cue for other essential signs.)

End walls or return walls in long corridors shall be visually defined using highly contrasting colours or tone to enhance a change of

direction or the end of the *space*. *Detectable warning* surfaces shall be used to define potential hazards. Refer to Section 1.2.6 Detectable Warning Systems.

All textured surfaces used as *detectable warning* devices shall be *cane-detectable* and clearly differentiated from the surrounding paving surfaces.

Suitable interior textures include raised domes, dots or squares in/on terrazzo or other stone-like materials, or applied carborundum or other non-slip strips.

Supplementary textural cues shall also be provided (e.g., by using different floor textures or materials, in major and minor routes).

Clearly defined boundaries of materials like carpeting or floor tiles shall enhance *wayfinding* by defining such as the junction between walls and floors, doorway recesses and corridor inter-sections.

Throughout any one *site*, the same texture shall be used to identify the same type of hazard.

RELATED SECTIONS

All relevant parts of Sections 1.0 General Design Standards, 2.0 Exterior Design Standards and 3.0 Interior Design Standards.

1.2.2 Acoustics

RATIONALE

The acoustic environment of public *buildings* and *spaces* should accommodate the unique needs of persons who are hard of hearing and who need to differentiate essential sounds from general background noise.

The acoustic characteristics of a *space* help to define it. The effect of movement on the sound in a *space* provides information that can be very useful to persons who have cognitive or vision *impairments* - although it may go unnoticed by other people.

Floor and wall coverings can be sound-reflective or sound absorbent. The finishes used changes the acoustic characteristics of the *space*. It is important that acoustic cues are clearly audible, and are not masked or garbled by other sounds. (Such as fans, elevator doors, *street* traffic, peoples voices, etc.) A person can use reflective sound to determine the size of the room, the presence of corridors or other circulation routes, the proximity of walls or other *elements*.

Within a built *space*, specific sounds can provide cues about the location of special features, such as an elevator. Avoid echo reflection and ambient sound (sound glare) as it interferes with the process of locating auditory cues.

The sound transmissions of different areas can be used as an

orientation cue and help to navigate a *space*.

APPLICATION

The acoustical environment of *facilities* used by the general public, clients, customers and employees shall comply with this section.

DESIGN REQUIREMENTS

Floor finishes, wall surfaces and ceilings shall be selected so that occasional noise is not unduly amplified. (e.g., Hard surfaces such as marble or terrazzo will allow each foot step to be heard by persons who are vision impaired, but add another level of confusion for persons who are hearing impaired.)

At *accessible routes* in large *facilities* where *wayfinding* is problematic, the sound transmission and reflection characteristics of finish materials shall aurally differentiate major and secondary paths of travel.

Ceiling shapes shall be designed so that echoes do not occur, unless an alternate acoustical treatment is incorporated. (Note: domed shapes tend to distort sound.)

In *meeting rooms* and *assembly areas* where the spoken word is key to comprehending the proceedings, all unnecessary background noise (e.g., from fans or other mechanical equipment, air diffusers, etc.) shall be dampened

and/or the room shall include adequate sound insulation.

RELATED SECTIONS

- 1.2.3 Public Address Systems
- 1.3.3 Public Telephones
- 3.2.1 Information, Reception and Service Counters
- 3.2.3 Office, Work Areas and Meeting Rooms
- 3.4.2 Assistive Listening Systems

GENERAL STANDARDS

1.2.3 Public Address Systems

RATIONALE

Public address systems should be designed to best accommodate all users, especially those who may be hard of hearing. They should be easy to hear above the ambient background noise of the environment and there should be no distortion or feedback. Background noise should be minimized.

Visual equivalents should be made available for individuals who may not hear an audible public address system.

APPLICATION

Public address systems shall comply with this section.

DESIGN REQUIREMENTS

Public address speakers shall be mounted above head level, and provide effective sound coverage in required areas, such as corridors, assembly and *meeting room* areas, recreational and entertainment *facilities*, educational *facilities*, and *common use* areas in institutional settings (i.e. washrooms)

Public address systems shall be zoned so that information can be directed to key locations only, minimizing background noise in other areas.

Public address and call systems shall be capable of being zoned to key areas, rather than blanketing all areas of a *facility* at all times.

All-point call systems shall only be utilized for fire and emergency information.

Paging systems for staff and other key persons shall be discreet and low volume, and sound only at those devices or locations where such persons might expect to be located.

RELATED SECTIONS

- 1.1.2 Protruding and Overhead Objects
- 1.2.2 Acoustics
- 3.1.8 Emergency Exits, Fire Evacuation and Areas of Rescue Assistance

1.2.4 Signage

RATIONALE

Signs provide essential information to everyone. *Signage* should be simple, uncluttered and incorporate plain language. Consistent placement of signage enhances usability for everyone. The use of graphic symbols is helpful for children, those with a limited literacy level, or for those who speak a different language.

Sharp contrasts in colour make *signage* easier for anyone to read, particularly someone with a vision *impairment*. The intent of the symbol must be evident, culturally universal and not counter intuitive. To enhance readability, raised *tactile* lettering should incorporate edges that are slightly smoothed. The use of the Canadian Institute of the Blind “Clear Print Guidelines” is recommended to assist with colour contrast.

Audible signs (infrared and digital) that are readable by visually impaired persons using a receiving device may be the sole orientation aid across *open spaces*. Consideration should be given to including wire drops for future installation.

Taking into account the level of complexity of some interpretive signs the character size requirements is lower. As an alternative format, having the provision of auditory commentary of the information provides equitable use for people who do not read print.

Information should be minimized

and clearly presented using sans-serif font. Never place print over background pictures.

Note: Interpretive signs should always be mounted in accordance with Figure 1.2.5.1.

Note: Traffic control devices, including traffic signs in the public *right-of-way*, must be in accordance with the *Manual of Traffic Control Devices for Canada* (MTCDC) or otherwise approved by *Manitoba Regulation 264/88 Traffic Control Devices*.

APPLICATION

Signage shall comply with this section.

Signs that designate permanent rooms or *spaces* shall be wall-mounted and include *tactile* characters and numbers.

Signs that provide direction to, or information about, functional *spaces*, shall comply with this section.

Elements and *spaces* of *accessible facilities* that shall be identified by the International Symbol

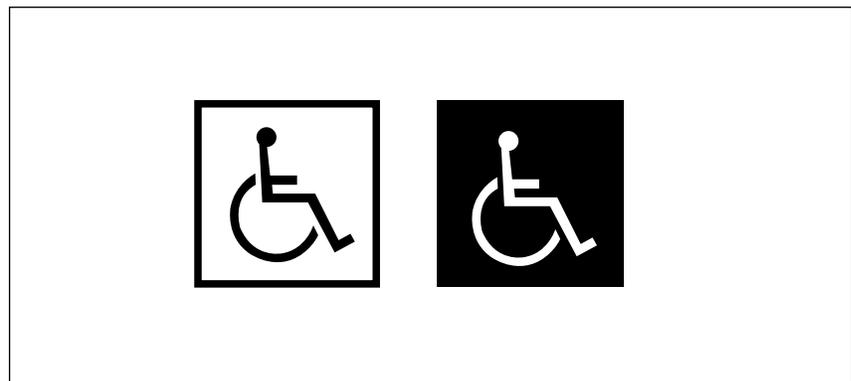

Figure 1.2.4.1 Colour Contrast on Signs / International Symbol of Access

Minimum character height, mm	Maximum viewing distance, mm
152 mm (6 in.)	over 4572 mm (15 ft.)
76 mm (3 in.)	2489 - 4572 (8 ft. 2 in. - 15 ft.)
51 mm (2 in.)	1524 - 2412 mm (5 ft. - 7 ft. 11 in.)
25 mm (1 in.)	761 - 1499 mm (2 ft. 6 in. - 4 ft. 11 in.)
less than 25 mm (1 in.)	under 601 mm (2 ft.)

Table 1.2.4.2 Character Height on Room Identifier Signs

GENERAL STANDARDS

1.2.4 Signage (continued)

of Accessibility are

- parking *spaces*, designated as reserved for individuals with *disabilities*;
- *accessible* passenger loading zones;
- *accessible entrances* when included with entrances that are not accessible (inaccessible *entrances* shall have directional *signage* to indicate the route to the nearest *accessible entrance*);
- *accessible* toilet and bathing *facilities*, including single-use portable units, when not all are *accessible*;
- *accessible* telephones;
- *accessible* elevators and other elevating devices;
- *accessible means of egress*; and
- *areas of rescue assistance*.

between 3:5 and 1:1; and

- have a stroke-width-to-height ratio between 1:5 and 1:10.

Character height dimensions for viewing distance shall comply with Table 1.2.4.1.

Characters, symbols and backgrounds of signs shall have an eggshell, matte or other glare-free finish.

Characters and symbols shall *colour contrast* with their background.

Signs must be context sensitive (i.e. navy or dark grey on an exterior non-lit sign will disappear at night)

Where signs are required to be *tactile*, letters and numerals shall be

- raised at least 0.8 mm (1/32 in.), not sharply edged;
- be between 16 mm (5/8 in.) and 50 mm (2 in.) high; and
- be a sans serif font, accompanied by Grade 1

uncontracted Braille.

Pictograms shall be accompanied by an equivalent visual and *tactile* verbal description, placed directly below the pictogram. The border dimension of the pictogram shall be 150 mm (6 in.) minimum in height.

Where permanent identification is provided for rooms and *spaces*, signs shall be installed on the wall adjacent to the latch side of the door, located with their centre line at a height between 1475 mm (58 in.) and 1525 mm (60 in.).

Where there is no wall *space* to the latch side of the door, including at double-leaf doors, signs shall be placed on the nearest adjacent wall, in a location that is easy to reach and touch.

Signs shall be *colour contrasted* to the surface they are mounted upon. Framing the sign with a boarder matching the pictogram could enhance the colour contrast. The boarder creates a 3D effect when placed against a colour contrasted surface or wall.

DESIGN REQUIREMENTS

Letters and numbers on signs shall

- be sans serif fonts;
- have Arabic numbers;
- have a width-to-height ratio

In crowded areas, signs shall be placed above head-level to increase their visibility.

The minimum level of illumination on signs shall be 200 lux (18.4 ft-candles).

All signs in the Riel Community area and Central office of the City of Winnipeg shall be bilingual in

Minimum character height	Signage text type
8 mm (1/3 in.)	captions
13 mm (1/2 in.)	body text
14 - 17 mm (5/8 - 2/3 in.)	subtitles
21 - 26 mm (13/16 - 1 in.)	titles
once the viewer is 1 meter (39 in.) from the sign, the font size will increase proportionally and double in size.	

Table 1.2.4.1 Character Height on Interpretive and *Wayfinding* Signage

1.2.4 Signage (continued)

English and French.

Character Height on Public Wayfinding Signs and Maps

Wayfinding sign and maps are tools intended for people of all ages and abilities to navigate through the city, regardless of their level of familiarity with the city.

Use of clear language and pictures of key features used on maps is imperative for those who may be unfamiliar with their surrounds. These key features should be tactile to insure use by individuals with vision impairments.

RELATED SECTIONS

All relevant parts of Sections 1.0 General Design Standards, 2.0 Exterior Design Standards and 3.0 Interior Design Standards.



Figure 1.2.4.3 Pictograms
(Note: Must incorporate equivalent verbal description)

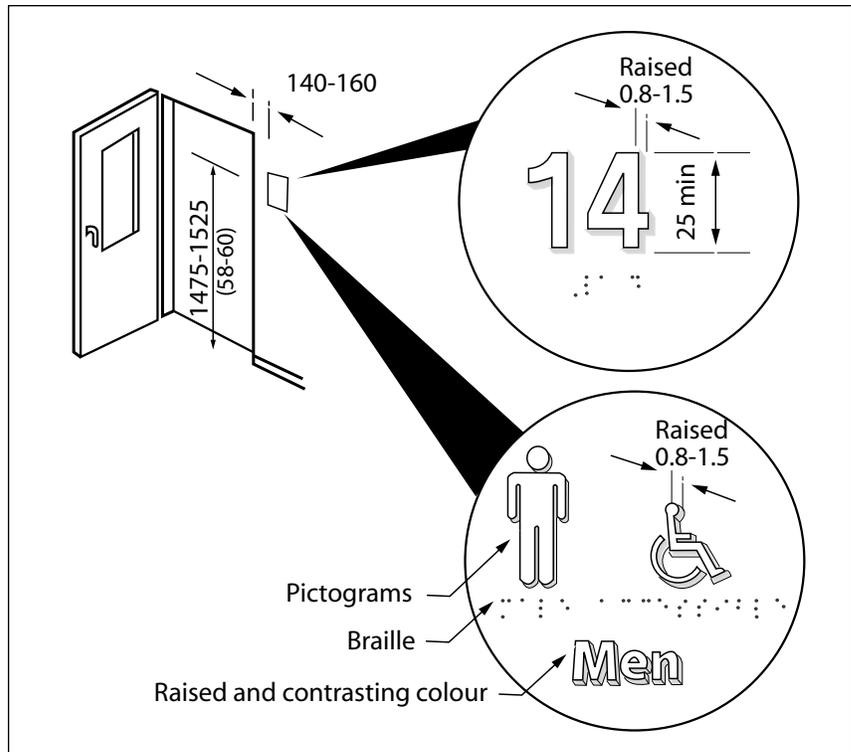

Figure 1.2.4.4 Tactile Lettering

GENERAL STANDARDS

1.2.5 Information Systems

RATIONALE

Information should be *accessible* to all facility users. Where universally *accessible* formats are technically not feasible alternate formats should be available. Video display terminals may present particular difficulties for persons with vision *impairments*. Alternate technology or audio interfaces are required. To ensure that a person using a wheelchair can access an information terminal, consideration should be given to the lower vantage point and reach ranges.

APPLICATION

Information systems, such as display kiosks, video display terminals and interpretive/informational panels shall comply with this section.

DESIGN REQUIREMENTS

Where information is provided by video display terminals the same information shall be provided in an alternative format, such as audio, Braille and large-text print. Refer to the Canadian National Institute of the Blind "Clear Print Guidelines" for further detail.

Information systems designed for direct access by the public, such as a touch-screen video display, shall have keyboard or keypads mounted at a height suitable for use by persons using wheelchairs or scooters as per Section 3.5.1 Controls and Operating Mechanisms. Essential information shall be displayed in large text on a

colour contrasting background and should also be available in other formats, such as audiotape or large-text print.

Push buttons or other controls for accessing public information systems should be clearly identifiable by colour and/or tone from the background colour, and should include raised numbers, numerals or symbols for easy identification by persons who are visually impaired. *Tactile* identification shall comply with Section 1.2.1 Texture, Finishes and Colour.

Exhibits that include important artefacts, labels and graphics, shall be placed 1000 - 1200 mm (39-3/8 - 47 in.) from the floor.

Labels and descriptive *signage* shall be inclined from horizontal

for easier reading.

Inclined informational/interpretive panels that can not be read from 750 mm (65 in.) away shall allow 660 mm (26 in.) of knee clearance from the ground and at least 470 mm (18 in.) depth. If displays are legible from 750 mm (65 in.) or further, less clearance is permitted to a minimum height of 220 mm (9 in.) for toe kick clearance.

No part of the sign shall encroach on the path of travel. If encroachment is unavoidable, *cane-detection* through colour and texture change shall be provided on the ground.

A minimum 1500 mm x 1500 mm (54 in. x 54 in.) *clear space* directly in front of the sign is required for its approach and use. The clear space must be of a hard surface material.

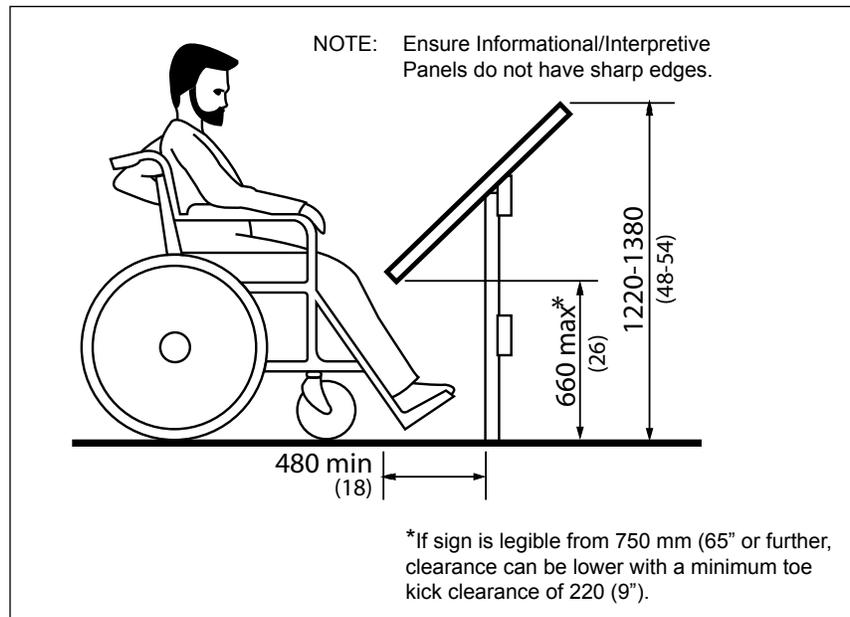

Figure 1.2.5.1 Informational/Interpretive Panel Clearances

1.2.5 Information Systems (continued)

RELATED SECTIONS

- 1.2.1 Texture, Finishes and Colour
- 1.2.2 Acoustics
- 1.2.3 Public Address Systems
- 1.2.4 Signage
- 2.1.3 Streetscape
- 3.5.1 Controls and Operating Mechanisms

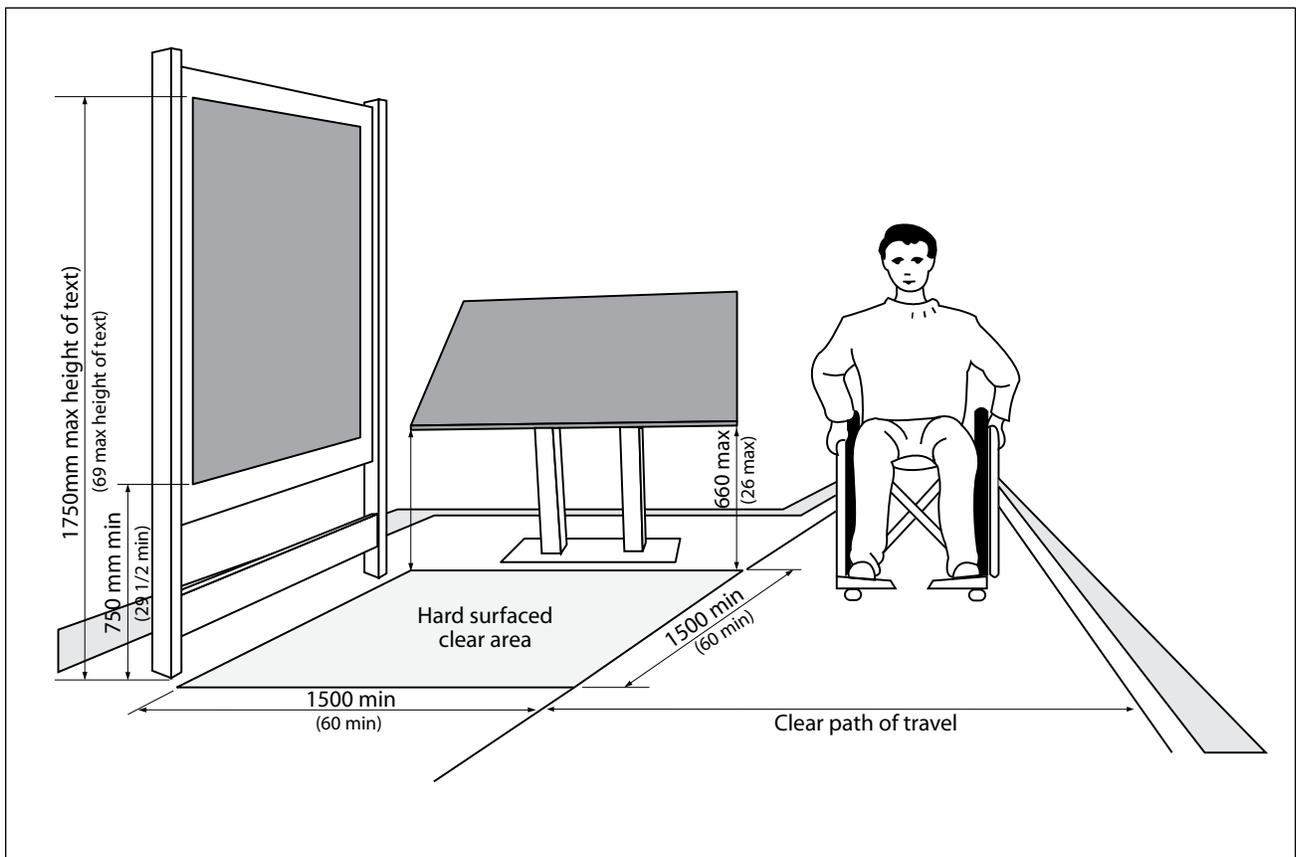

Figure 1.2.5.2 Informational/Interpretive Information Systems

GENERAL STANDARDS

1.2.6 Detectable Warning Systems

RATIONALE

Detectable warning surfaces provide important navigation cues for persons with a vision *impairment*. These surfaces alert all pedestrians to potential hazards, such as crosswalks or stairs. Suitable surfaces include a change in texture and high *colour contrast* but should not present a tripping hazard. *Detectable warning surfaces* should be used consistently throughout a *facility*.

APPLICATION

Detectable warnings at walkways, curb ramps, stairs and raised platforms shall comply with this section.

DESIGN REQUIREMENTS

All textured surfaces used as *detectable warning surfaces* shall be *cane-detectable* and clearly differentiated from the surrounding ground or floor surfaces. Refer to Section 1.2.1 Texture, Finishes and Colour.

Detectable warning surfaces shall contrast visually with adjoining surfaces by a minimum of 70% *colour contrast*, either light on dark or dark on light. Exterior *detectable warning surfaces* installed in asphalt or concrete shall be yellow only.

Detectable warning surfaces at stairs shall

- be provided at the top of the stairs and at landings; and

- extend the full width of the stair for a depth of at least 920 mm (36 in.) commencing one tread depth back from the stair.

Detectable warning surfaces at ramps shall

- be provided at the top and bottom of each *ramp*;
- extend the full width of the

- ramp* for a depth of at least 920 mm (36 in.); and
- not extend into the door swing area.

Detectable warning surfaces at elevated platforms shall

- be composed of *truncated domes*
- with a height of 4.5 - 5.5 mm (0.18 to 0.22 in.);

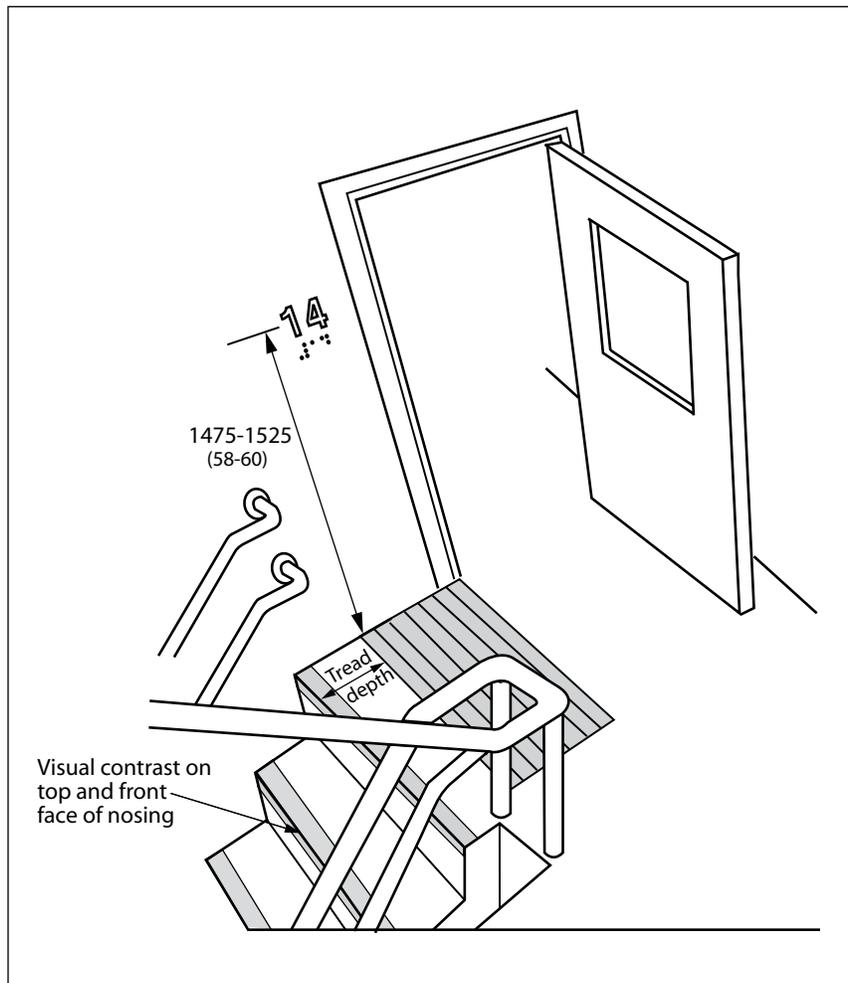

Figure 1.2.6.1 Detectable Warnings at Stairs

1.2.6 Detectable Warning Systems (continued)

- with a base diameter of 21-25 mm (0.83 to 0.98 in.); and
- be organized in a regular pattern with spacing of 55-65 mm (2-3/16 to 2-9/16 in.) on centre;
- be slip resistant when dry or wet; and
- contrast visually with adjoining surfaces

Note: For installation configurations for *detectable warning* surfaces at *curb ramps* refer to Section 2.1.5 Curb Ramps and Truncated Dome Detectable Warning Surfaces.

If a *walk* crosses or joins a *vehicular way* and the walking surfaces are not separated by curbs, railings or other *elements* between the pedestrian areas and vehicular areas, the boundary between the areas shall be defined by a continuous *detectable warning surface*, which is 920 mm (36 in.) wide.

RELATED SECTIONS

- 1.1.2 Protruding and Overhead Objects
- 1.1.3 Accessible Routes, Paths and Corridors
- 1.1.5 Ramps
- 1.1.6 Stairs
- 1.2.1 Texture, Finishes and Colour
- 1.3.1 Drinking Fountains
- 2.1.3 Streetscape
- 2.1.5 Curb Ramps and Truncated Dome Detectable Warning Surfaces
- 2.3.1 Parking
- 3.1.7 Escalators
- 3.2.3 Passenger Loading

1.2 GENERAL INFORMATION AND COMMUNICATION SYSTEMS

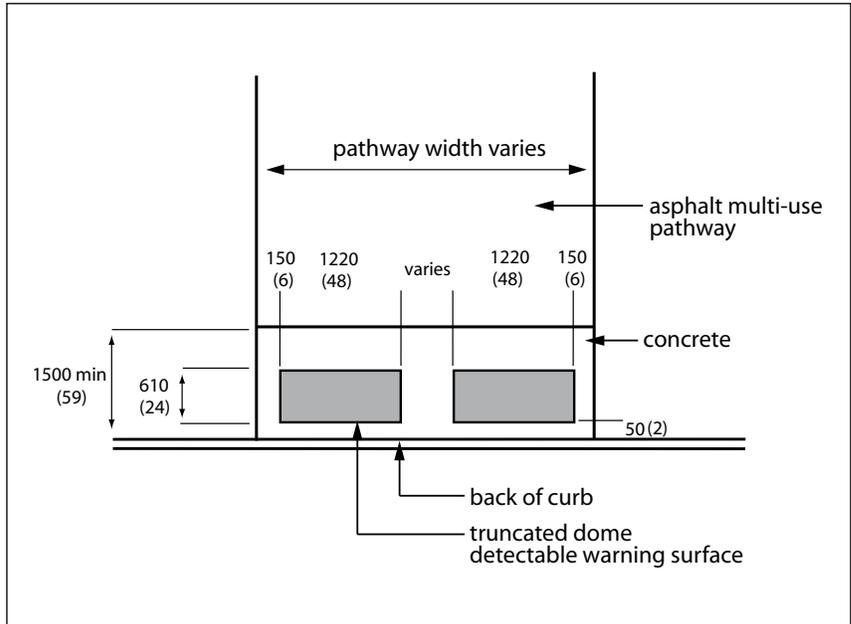

Figure 1.2.6.2 Detectable Warnings at *Multi-Use Pathways*

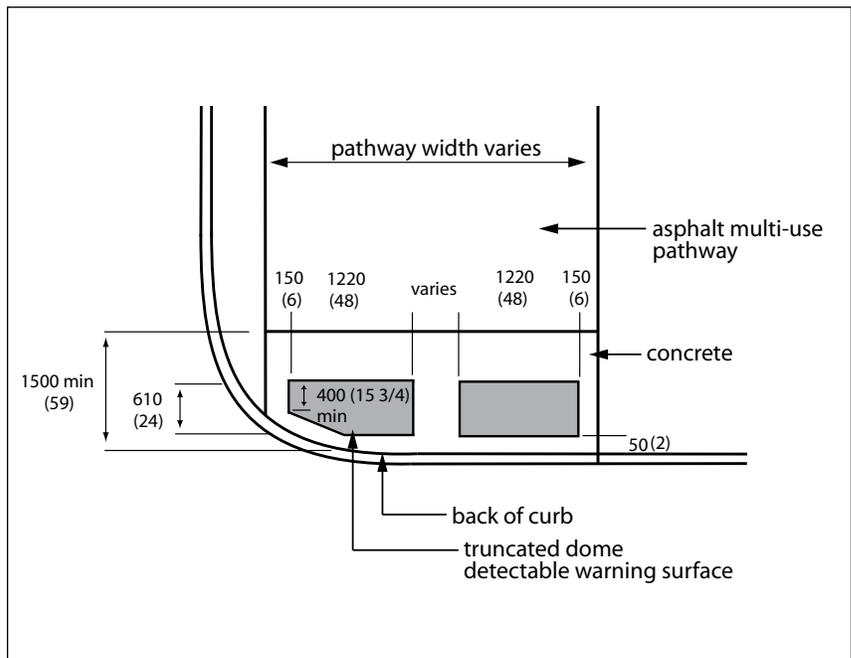

Figure 1.2.6.3 Detectable Warnings at *Multi-Use Pathway Curb Junctions*

GENERAL STANDARDS

1.3.1 Drinking Fountains

RATIONALE

Planning for the design of drinking fountains should consider the limited height of children or persons using a wheelchair. In the same respect, there may be individuals who have difficulty bending who would require a higher fountain. The operating system should account for limited hand strength or dexterity. The placement of the fountain is also important. Fountains should be recessed to avoid protruding into the path of travel, especially if they are wall mounted above the height of *cane-detection*.

APPLICATION

Where only one drinking fountain is provided on a floor, it shall incorporate components that are *accessible* to individuals who use wheelchairs in accordance with this section, as well as components that are *accessible* to persons who have difficulty stooping or bending.

Where more than one drinking fountain or water cooler is provided on a floor, at least 50% shall comply with this section.

DESIGN REQUIREMENTS

Accessible drinking fountains shall

- be located on an *accessible route* complying with 1.1.3;
- have a spout located near the front of the unit between 760 mm (30 in.) and 900 mm (35

in.) above the floor or ground surface;

- have a spout that directs the water flow in a trajectory that is parallel or nearly parallel to the front of the unit;
- have a spout that provides a water flow at least 100 mm (4 in.) high; and
- be equipped with controls that are located on the front of the unit, or on both sides of the unit, easily operated from a wheelchair, using one hand, with a force of not more than 22 N (4.9 lb.), or be automatically operable.

Cantilevered drinking fountains shall

- have a *clear space* of at least 900 mm (35-1/2 in.) by 1500 mm (59 in.);
- have a *knee space* between the bottom of the apron and the floor or ground of at least 900 mm (35-1/2 in.) wide, 200 mm (7-7/8 in.) deep and 685 mm (27 in.) high;
- have a *toe space* not less than 900 mm (35-1/2 in.) wide, 230 mm (9 in.) deep, and 230 mm (9 in.) high; and
- be recessed or otherwise located out of the circulation route.

Cantilevered drinking fountains that project into an *accessible route* shall be identified by a *detectable warning* surface of at least 300 mm (11-3/4 in.) around the object, installed flush with the walkway surface.

Freestanding or built-in fountains not having a *knee space* shall have a *clear space* at least 1500 mm (59 in.) wide by 900 mm (35-1/2 in.) deep in front of the unit.

RELATED SECTIONS

- 1.1.1 Space and Reach Requirements
- 1.1.2 Protruding and Overhead Objects
- 1.1.3 Accessible Routes, Paths and Corridors
- 1.2.1 Texture, Finishes and Colour
- 2.1.1 Exterior Ground Surfaces
- 2.1.3 Streetscape
- 3.1.1 Interior Floor Surfaces

1.3.1 Drinking Fountains (continued)

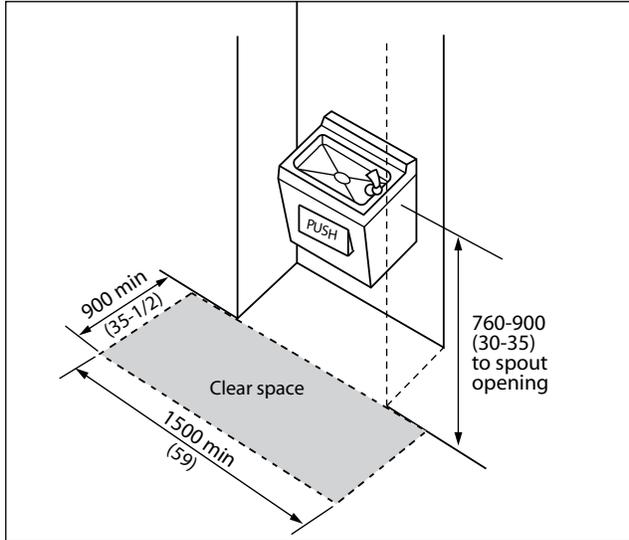

Figure 1.3.1.1 Parallel Approach to Drinking Fountain

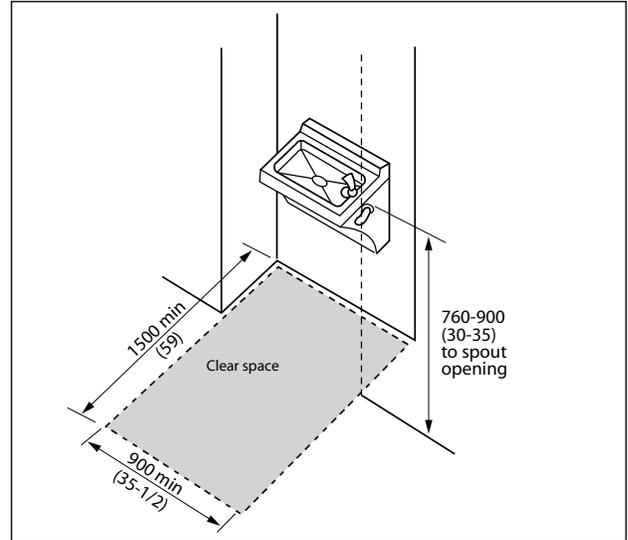

Figure 1.3.1.2 Frontal Approach to Drinking Fountain

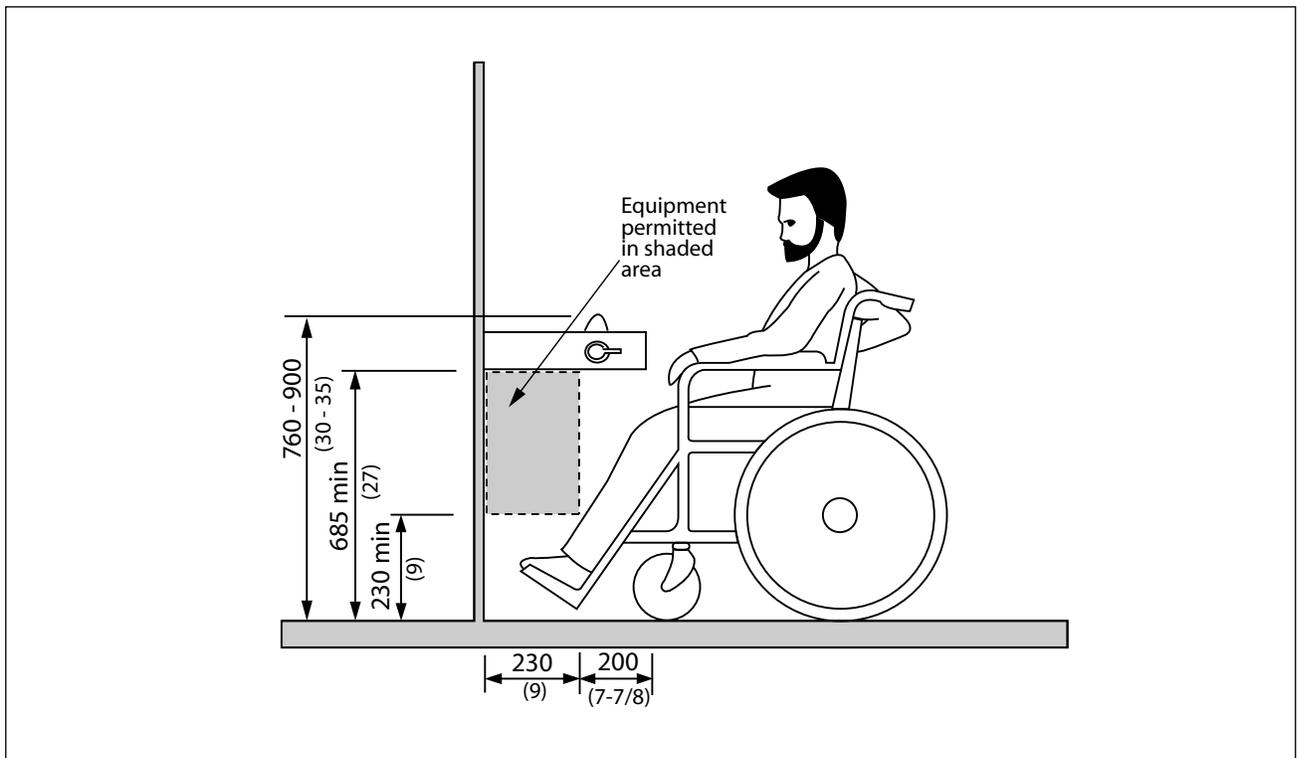

Figure 1.3.1.3 Clearances at Drinking Fountain

1.3 GENERAL AMENITIES

GENERAL STANDARDS

1.3.2 Vending and Ticketing Machines

RATIONALE

Space in front of vending machines allows for maneuverability of mobility aids. Seating areas and tables adjacent to vending machines offer convenience and should accommodate the spatial requirements of wheelchairs. The selection of the machines should include a number of factors. Operating mechanisms should be within reach of children and individuals in wheelchairs. The mechanisms should be operable with one hand and minimal strength, to accommodate people with limitations in dexterity. Lighting levels and *colour contrasts* make the machine more *accessible* to those with vision *impairments*.

APPLICATION

Vending and ticketing machines

shall comply with this section.

DESIGN REQUIREMENTS

Vending and ticketing machines shall be located on an *accessible route* in compliance with Section 1.1.3 Accessible Routes Paths, and Corridors.

Ticket dispensing machines and payment machines located along vehicular routes, shall be reachable from a vehicle.

Clear space in front of vending and ticketing machines shall conform to Section 1.1.1 Space and Reach Requirements.

The controls and operating mechanisms on vending and ticketing machines shall comply with Section 3.5.1 Control and Operating Mechanisms.

Signage on vending and ticketing machines shall be in highly contrasting lettering, at least 13 mm (1/2 in.) high. Ideally, lettering and *signage* shall comply with relevant parts of Section 1.2.4 Signage.

RELATED SECTIONS

- 1.1.1 Space and Reach Requirements
- 1.1.2 Protruding and Overhead Objects
- 1.1.3 Accessible Routes, Paths and Corridors
- 1.2.1 Texture, Finishes and Colour
- 2.1.3 Streetscape
- 3.5.1 Controls and Operating Mechanisms

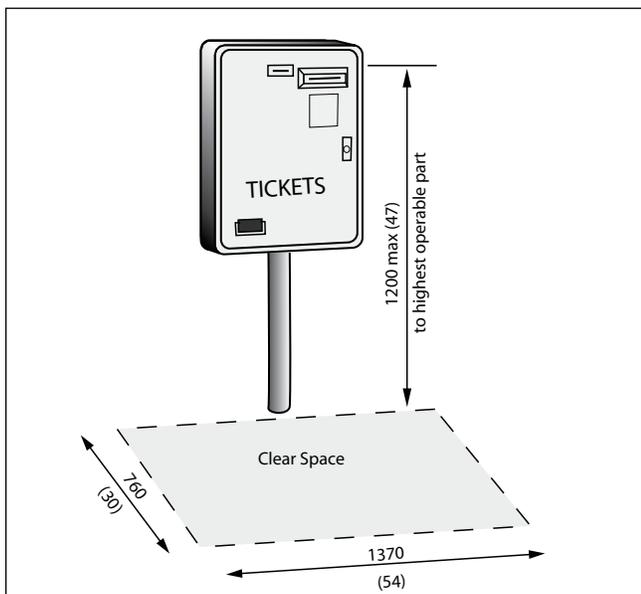

Figure 1.3.2.1 Ticket Dispensing Machine

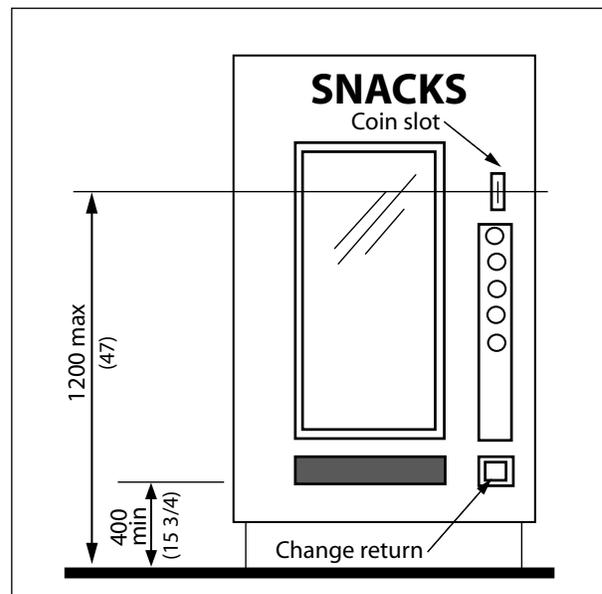

Figure 1.3.2.2 Vending Machine

1.3.3 Public Telephones

RATIONALE

The placement of telephones should address the limited reach of children or persons seated in wheelchairs. Longer cords facilitate the use of the phone for someone unable to get close to the phone. Adjustable volume controls are important for hearing impaired individuals, as are shelves that can support a *TTY*.

A fold-down seat is an asset for someone who has difficulty standing for extended periods. Telephones projecting from a wall may present a hazard, particularly to persons with vision *impairments* if the sides are not configured to be *cane-detectable*.

APPLICATION

Where public pay phones, public closed circuit phones, or other public telephones are provided, they shall comply with this section to the extent required by Table 1.3.3.

All telephones required to be *accessible* shall be equipped with a volume control. In addition, 25%, but never less than one, of all other public telephones provided shall be equipped with a volume control and shall be dispersed among all types of public telephones, including *closed-circuit telephones*, throughout the *facility*.

Signage complying with Section 1.2.4 Signage shall be provided.

Where an interior public pay telephone is provided, then at least one interior public *text TTY* shall be provided in the *facility* in a *public use area*.

Where an interior public pay telephone is provided in the secured area of a detention or correctional *facility* subject to Section 3.6.5 Emergency Services, then at least one public *TTY* shall also be provided in at least one secured area. Secured areas are those areas used only by detainees or inmates and security personnel.

DESIGN REQUIREMENTS

Accessible telephones shall be on an *accessible route* complying with Section 1.1.3 Accessible Routes, Paths and Corridors.

Telephones, enclosures and related equipment shall comply with Section 1.1.2 Protruding and Overhead Objects.

Telephones shall have push-button controls where service for such equipment is available. The characters on the push buttons shall contrast with their background, which should be non-glare (matte finish), and the buttons themselves should contrast with their background.

The minimum handset cord length of *accessible* telephones shall be 1000 mm (39-3/8 in.).

The minimum illumination level at operating mechanisms, the directory, and shelf of *accessible* telephones shall be 200 lux (18.4 ft-candles).

Telephones for persons in wheelchairs shall

- have the maximum height of *operable portions*, including the coin slot, 1200 mm (47 in.) above the floor;
- have a *clear space* not less than 760 mm (30 in.) wide

Number of each type of telephone provided on each floor	Number of telephones required to comply with this section
1 or more single unit	1 per floor
1 bank	1 per floor
2 or more banks	1 per bank. <i>Accessible</i> unit may be installed as a single unit in proximity to (either visible or with <i>signage</i>) the bank. At least one public telephone per floor shall meet the requirements for a forward reach telephone.

Table 1.3.3.1 *Accessible Telephone Requirements*
 Note: A bank consists of two or more adjacent public telephones, often installed as a unit.

GENERAL STANDARDS

1.3.3 Public Telephones (continued)

by 1370 mm (54 in.) deep in front of the telephone, and this *space* may extend a maximum of 480 mm (18-7/8 in.) underneath the telephone if a *clear* height of 720 mm (28-3/8 in.) is provided for knee *space*; and

- have a flat telephone directory shelf at least 500 mm (19-3/4 in.) wide and 350 mm (13-3/4 in.) deep.

TTY's used with a pay telephone shall be permanently affixed within, or adjacent to, the telephone enclosure. If an acoustic coupler is used, the telephone cord shall be sufficiently long to allow connection of the TTY and the telephone receiver.

Where additional telephones are provided for use by persons who are deaf or hard of hearing, and these telephones are designed to accommodate a portable TTY the telephones shall

- comply with CSA Standard T515;
- have a shelf at least 250 mm (9-7/8 in.) wide by 350 mm (13-3/4 in.) deep;
- be equipped with an electrical outlet, within or adjacent to the telephone enclosure; and
- be equipped with a handset capable of being placed flush on the surface of the shelf.

Accessible telephones shall be identified by the appropriate symbol of accessibility for mobility impaired persons and/or persons who are deaf or hard of hearing.

When directional signs for telephones are installed, they shall include the appropriate access symbols.

RELATED SECTIONS

- 1.1.1 Space and Reach Requirements
- 1.1.2 Protruding and Overhead Objects
- 1.1.3 Accessible Routes, Paths and Corridors
- 1.2.1 Texture, Finishes and Colour
- 1.2.4 Signage
- 2.1.2 Exterior Lighting
- 2.1.3 Streetscape
- 3.5.1 Controls and Operating Mechanisms
- 3.5.3 Interior Lighting

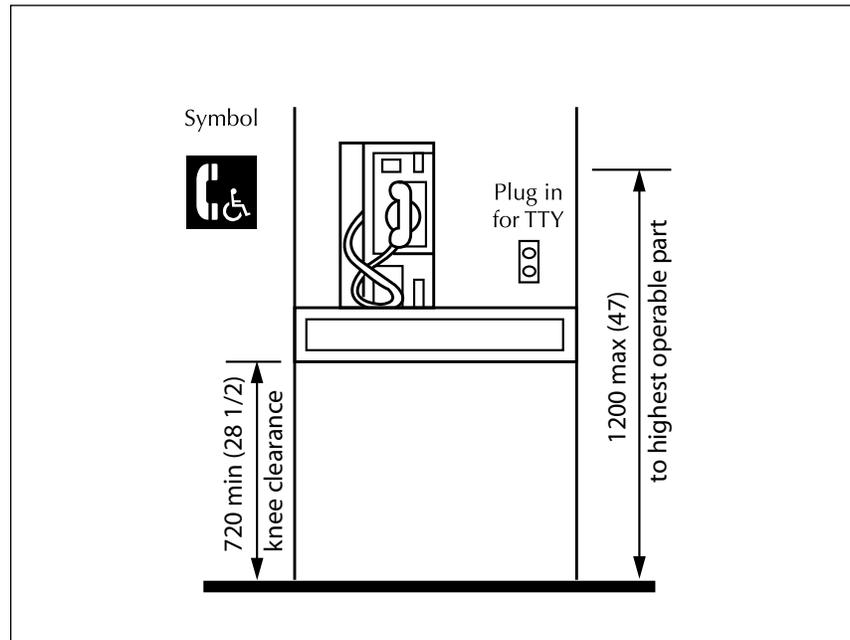

Figure 1.3.3.1 Public Telephone Requirements

1.3.3 Public Telephones (continued)

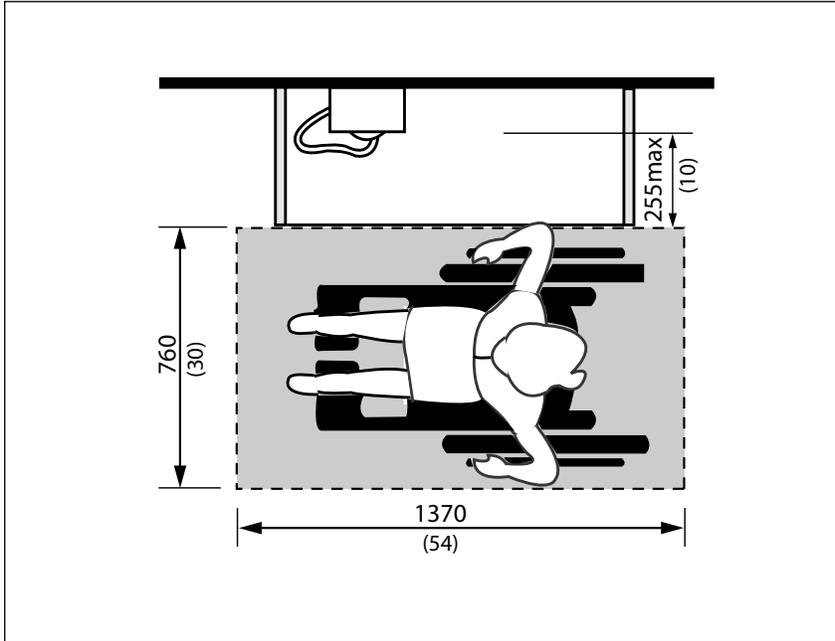

Figure 1.3.3.2 Parallel Approach to Public Telephone

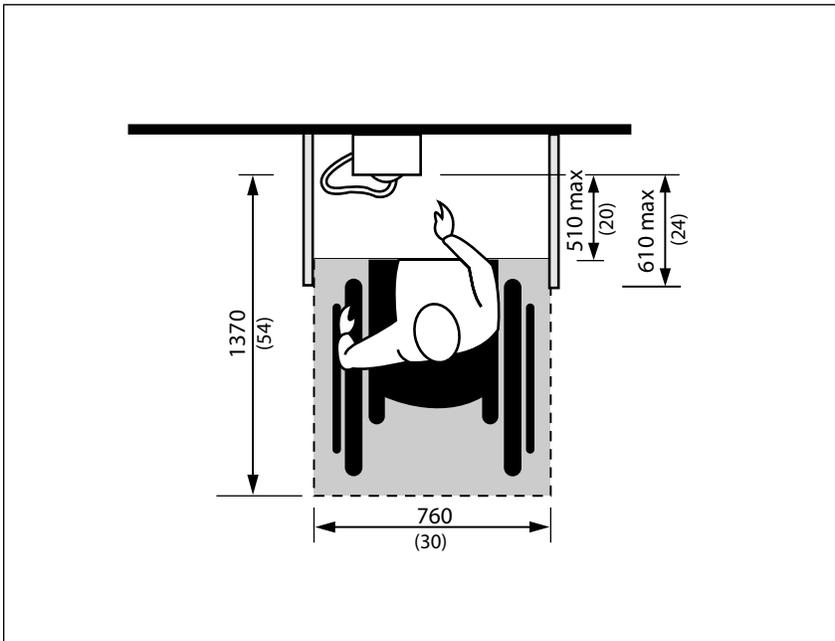

Figure 1.3.3.3 Frontal Approach to Public Telephone

1.3 GENERAL AMENITIES

GENERAL STANDARDS

1.3.4 Elevated Areas and Platforms

RATIONALE

Elevated areas and platforms, such as stage areas, speaker podiums, etc., should be *accessible* to all. A marked *accessible route* should be provided, along with safety features to assist persons who are visually impaired.

APPLICATION

Elevated platforms provided for use by the general public, clients, customers or employees shall comply with this section.

DESIGN REQUIREMENTS

Elevated platforms shall

- be located on an *accessible route* that complies with Section 1.1.3 Accessible Routes, Paths and Corridors;
- in a retrofit situation, or when an *accessible route* is not available, be fitted with a ramp in compliance with Section 1.1.5 Ramps or a lift in compliance with Section 3.1.6 Platform Lifts;
- be capable of being illuminated to at least 100 lux (9.3 ft-candles) at floor level at the darkest point;
- be sized to safely accommodate wheelchairs and other mobility equipment in compliance with Section 1.1.1 Space and Reach Requirements; and
- where higher than 200 mm (7-7/8 in.) have open platform

edges defined by a *detectable warning* surface

Note: Where it is *technically not feasible* to comply with the above requirements, a temporary lift may be sufficient.

The *detectable warning* surface on elevated platforms shall

- comply with the requirements of Section 1.2.6 Detectable Warning Surfaces;
- be consistent throughout the setting;
- be positioned parallel to the open platform edge, extending the full length of the platform; and
- be a minimum depth of 600 mm (23-5/8 in.) and a maximum of 920 mm (36 in.), flush from the open edge of the platform.

Where speaker podiums are provided they shall

- be located on an *accessible route* in compliance with Section 1.1.3 Accessible Routes, Paths and Corridors;
- be height-adjustable for use from a seated or standing position;
- incorporate *clear* space of at least 900 mm (35-1/2 in.) by 1500 mm (59 in.), configured for forward approach;
- incorporate *clear knee space* of at least 800 mm (31-1/2 in.) wide, 500 mm (19-5/8 in.) deep and 700 mm (27-1/2 in.)

high; and

- incorporate controls and operating mechanisms in compliance with Section 3.5.1 Controls and Operating Mechanisms.

RELATED SECTIONS

- 1.1.1 Space and Reach Requirements
- 1.1.2 Protruding and Overhead Objects
- 1.2.1 Texture, Finishes and Colour
- 1.2.6 Detectable Warning Surfaces
- 2.1.1 Exterior Ground Surfaces
- 2.1.3 Streetscape
- 3.1.1 Interior Floor Surfaces

1.3.4 Elevated Areas and Platforms (continued)

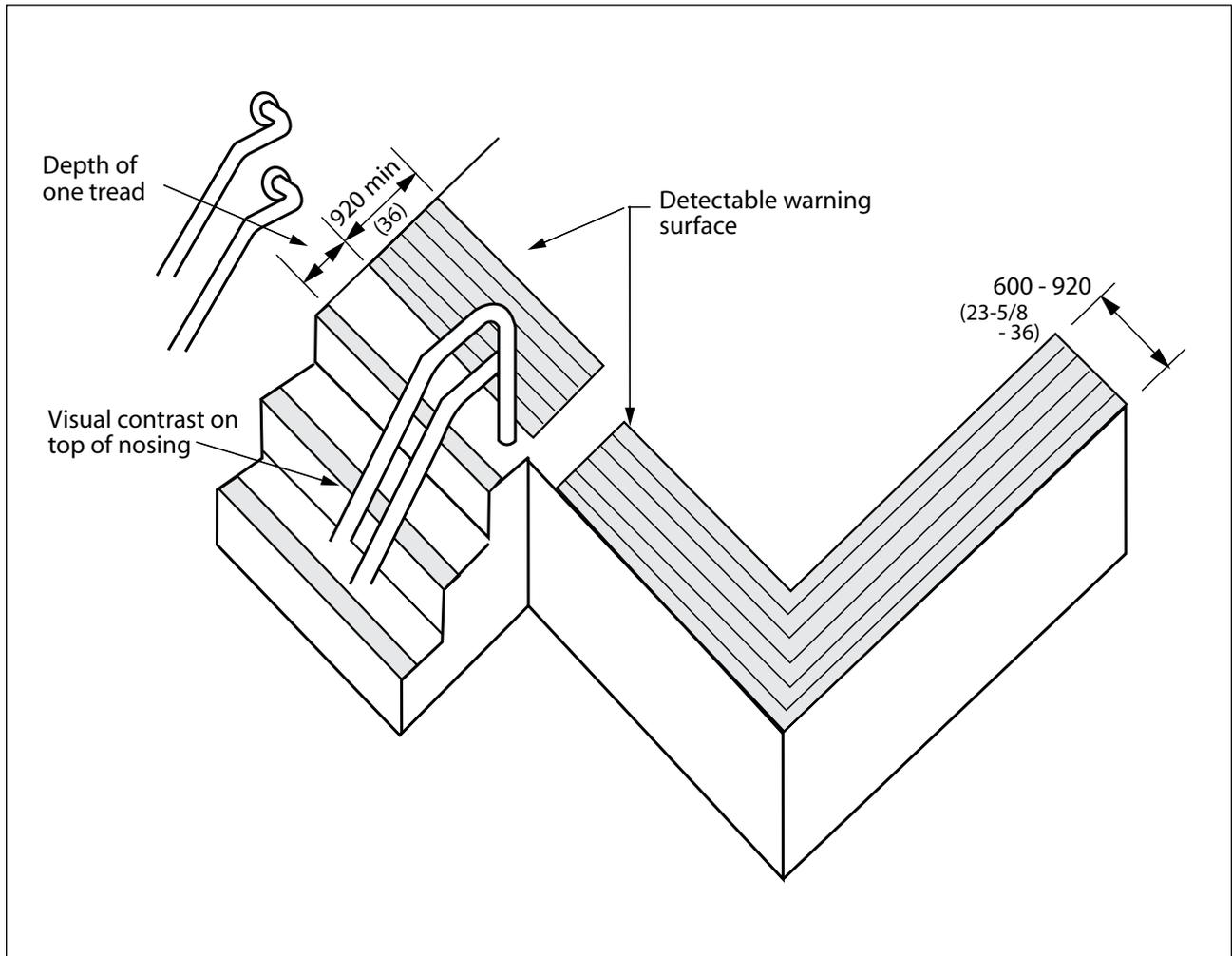

Figure 1.3.4.1 Detectable Warning Surfaces at Elevated Platform

1.3 GENERAL AMENITIES

GENERAL STANDARDS

1.3.5 Waiting and Queuing Areas

RATIONALE

Queuing areas for information, tickets or services should permit persons in wheelchairs or others with *disabilities* to move through the line safely and conveniently.

Waiting and queuing areas need to provide *space* for mobility devices, such as wheelchairs and scooters. Queuing lines that turn corners or double back on themselves will need to provide adequate *space* to maneuver mobility devices. Providing *handrails* in queuing lines may be useful support for individuals and guidance for those with vision *impairments*. The provision of benches in waiting areas is important for individuals who may have difficulty standing for extended periods.

Rope queuing systems are difficult for people who are visually impaired to use, and are a hazard to them when they walk through a queuing area.

APPLICATION

Waiting and queuing areas shall comply with this section.

DESIGN REQUIREMENTS

Barriers at queuing areas shall be laid out in parallel, logical lines, spaced a minimum of 1060 mm (42 in.) apart.

Barriers at queuing areas, provided to streamline people movement, shall be firmly mounted to the floor, and should have rigid

rails to provide support for waiting persons.

Where floor slots or pockets are included to receive temporary or occasional supports, such slots or pockets shall be level with the floor finish and have an integral cover, so as not to cause a tripping hazard.

Permanent queuing areas shall incorporate clearly defined floor patterns, colours and textures in compliance with Section 1.2.1 Texture, Finishes and Colour, as an aid to persons who are visually impaired.

There shall be a pronounced colour and texture contrast between ropes, bars or solid barriers used to define queuing areas and the surrounding environment.

Benches near queuing areas shall

- be designed to carry a minimum load of 2.27 kN (500 lbs.);
- have a variety of benches with and without armrests to accommodate individual abilities, sizes, and shapes.

RELATED SECTIONS

All relevant parts of Sections 1.0 General Design Standards, 2.0 Exterior Design Standards and 3.0 Interior Design Standards.

1.3.6 Benches

RATIONALE

Indoor and outdoor benches provide convenient resting places for all individuals and are especially important for those who may have difficulty with standing or walking for extended periods.

Benches should be placed adjacent to pedestrian walkways to provide convenient rest places without becoming potential obstructions. Appropriate seat heights can facilitate sitting and rising for individuals such as senior citizens. Armrests may also provide assistance in sitting and rising. Ensure arm rest positioning and structural supports can accommodate people of different sizes and weights. For this reason, center armrests may be appropriate in some instances. Adequate supports provide for comfortable and safe seating for people of larger stature. Persons who are blind will find it easier to locate benches if they are located adjacent to a landmark, such as a large tree, a bend in a pathway, or a sound source.

APPLICATION

All benches and seating areas, except those located on an accessible route in a dressing room, soft surface areas of *parks*, wilderness, beach or other non-hard surfaced areas, shall be *accessible* to all persons.

Benches in dressing rooms shall comply with Section 3.2.6 Specialty Change Rooms.

DESIGN REQUIREMENTS

Benches shall

- be adjacent to an *accessible route* complying with Section 1.1.3 Accessible Routes, Paths and Corridors;
- be stable;
- have a seat height between 430 mm (17 in.) and 500 mm (19-5/8 in.) from the ground;
- a seat depth of at least 444 mm to 610 mm (17 1/2 in to 24 in.);
- have a minimum of two arm rests that
 - shall be spaced no more than 700 mm (27 1/2 in.) and no less than 610 mm (24 in.). Where center armrests are provided they must allow a minimum seating area of 610 mm (24 in.).
- incorporate a minimum of one bench with a back that
 - is equal to the seat length that extends from a point no more than 50 mm (2 in.) above the seat surface to a point no less than 420 mm (16 1/2 in.) above the seat; and
 - is located no more than 64 mm (2-1/2 in.) from the seat surface to the horizontal back boards of the seat;
- be *colour contrasted* to their background;
- remain stable when a horizontal or vertical load of 1.112 kN (250 pounds) is applied to any point on the seat, fastener, mounting device, or

- supporting structure;
- where installed in wet locations, the surface of the seat shall be slip-resistant and shall not accumulate water; and
- have an adjacent level, firm ground surface at least 920 mm (36 in.) x 1500 mm (59 in.), located at least 300 mm (12 in.) back from the *accessible* route. It is preferred that this adjacent surface be colour and texture contrasted to the *accessible* routes.
- have a load capacity of (2.27 kN (500 lbs.).

RELATED SECTIONS

- 1.1.1 Space and Reach Requirements
- 1.1.2 Protruding and Overhead Objects
- 1.1.3 Accessible Routes, Paths and Corridors
- 1.2.1 Texture, Finishes and Colour
- 1.2.6 Detectable Warning Surfaces
- 2.1.1 Exterior Ground Surfaces
- 2.1.3 Streetscape
- 3.1.1 Interior Floor Surfaces

GENERAL STANDARDS

1.3.6 Benches (continued)

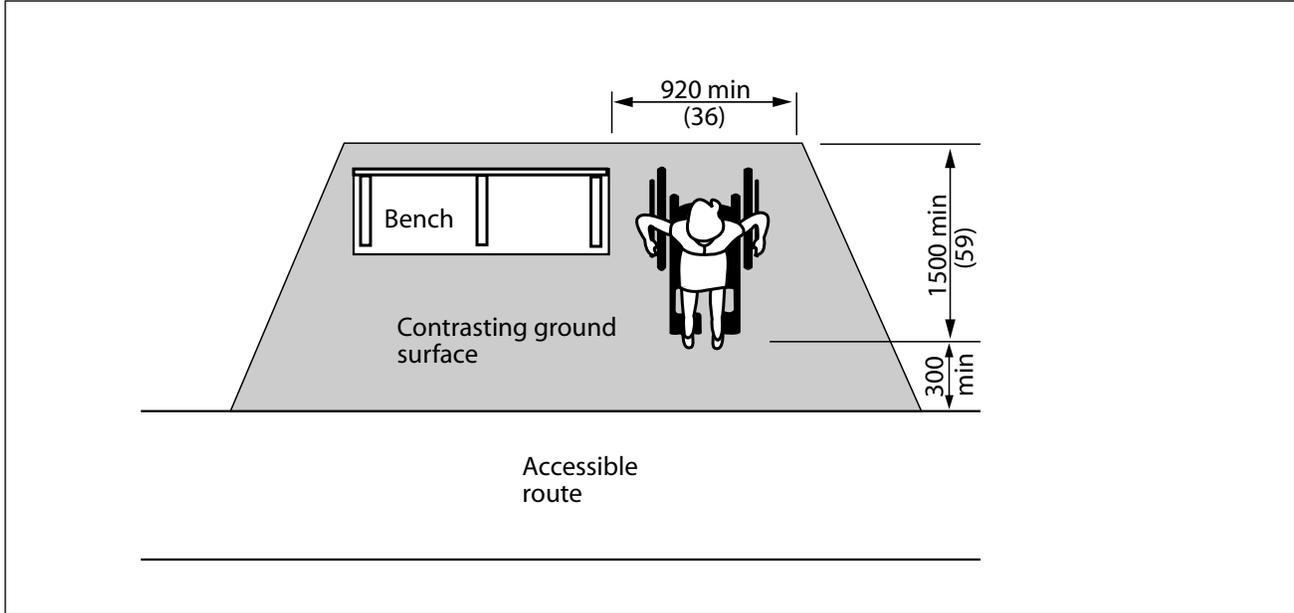

Figure 1.3.6.1 Bench in a Rest Area

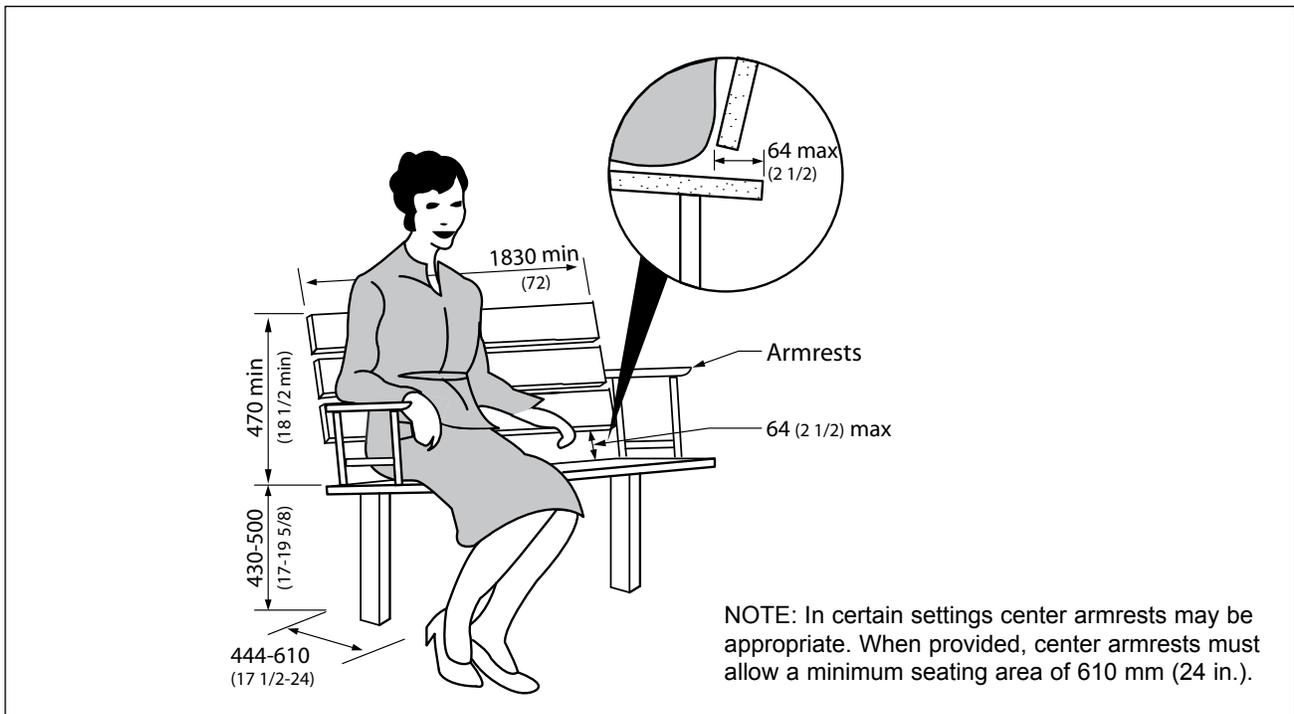

Figure 1.3.6.2 Example of Accessible Bench Seating

1.3.6 Benches (continued)

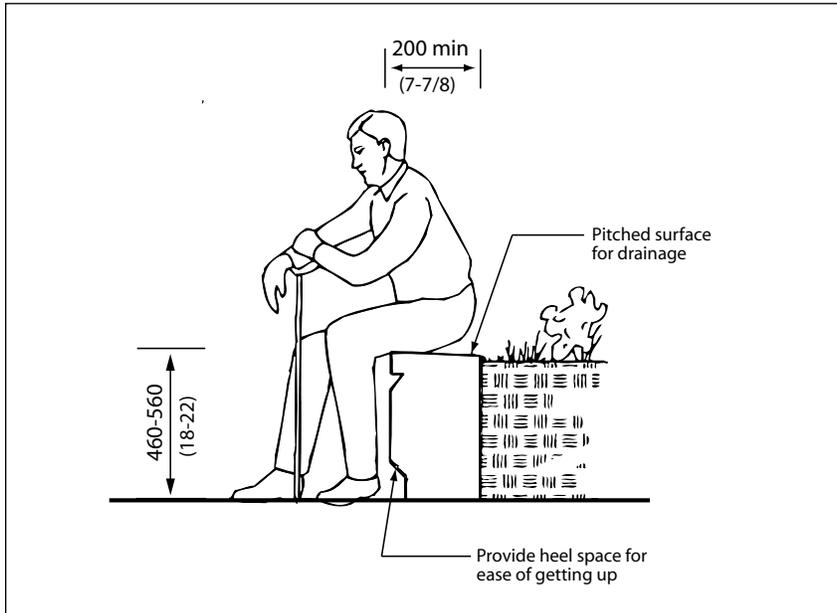

Figure 1.3.6.3 Example of Ledge Seating (Metric Handbook, Planning and Design Data, Second Edition)

GENERAL STANDARDS

1.4.1 Swimming Pools

RATIONALE

Considerations for accommodating persons who have mobility impairments include accessible change facilities and a means of access into the water. *Ramped* access into the water is preferred over lift access, as it promotes integration (everyone will use the *ramp*) and independence.

Many persons who are visually impaired will benefit from colour and textural cues along primary routes of travel and at potentially dangerous locations, such as the edge of the pool, at steps into the pool, and at railings.

Pools which feature the water level at the same level as the deck ('level-deck' design) are preferred.

APPLICATION

In addition to the design requirements specified throughout the document, swimming pools, wading pools, hot pools, splash pads and therapy pools shall comply with this section.

DESIGN REQUIREMENTS

Swimming pools, wading pools, hot pools and therapy pools shall have

- a specialty change room shall be provided in compliance with Section 3.2.6 Specialty Change Rooms;
- where the pool is indoors, a direct *accessible route*

in compliance with Section 1.1.3 Accessible Routes, Paths and Corridors, from the lobby/*entrance* to the change rooms;

- a direct *accessible route* in compliance with Section 1.1.3 Accessible Routes, Paths and Corridors, from the change rooms to the shallow end of the pool deck;
- access from the pool deck into the water, provided by a sloped entry in compliance with this section. In *retrofit* situations where it is *technically not feasible* to provide a *ramp*, a mechanical pool lift can be used;
- a shower chair available at each *facility* for use in transferring into the water and/or shower;
- where steps are provided into the pool, steps marked with a *colour contrasting* strip at least 50 mm (2 in.) wide, at both the riser and the tread;
- where steps are provided into the pool, *colour contrasting handrails* on both sides of the steps. Such *handrails* shall extend at least 300 mm (11-3/4 in.) beyond the pool edge;
- where an up-stand edge is provided, it shall be a minimum of 200 mm (7-7/8 in.) and a maximum of 400 mm (15-3/4 in.) in height;
- pool boundaries clearly defined by both a textural change and a *colour contrast* to both the water surface and surrounding pavement;
- firm, slip-resistant materials

and finishes used on the pool perimeter, deck or paved areas surrounding the pool;

- non-abrasive and easy-to-clean pool perimeter finishes;
- adequate drainage on the pool deck to drain water quickly;
- where pool-depth indicator marking is provided, depth-indicator markings, as well as 'SHALLOW END' and 'DEEP END' markings, of a highly contrasting colour and sufficient size to be easily visible;
- where diving boards or platforms are provided, they shall be clearly marked and protected. Overhead clearances should be a minimum of 2100 mm (82-3/4 in.) or protected by suitable *guards*;
- where lanes, and/or lane markers are provided, they shall be of a highly contrasting colour. Tie-off devices for lane markers shall be positioned such that they do not create a tripping hazard;
- where starting blocks are provided, they shall be of a highly contrasting colour and capable of being securely fixed in place;
- safety equipment and other accessories shall be stored such that they do not present a tripping hazard; and
- lifeguard chairs, slides and other pool related structures shall be in highly contrasting colours.
- Sloped entries into pools shall comply with Sections 1.1.5

1.4 GENERAL CONTEXT SPECIFIC REQUIREMENTS

1.4.1 Swimming Pools (continued)

Ramps and 1.1.7 Handrails and Guards, except as modified below.

Sloped entries shall

- extend to a depth of 610-760 mm (24-30 in.) below the stationary water level;
- where landings are required by 1.1.5, at least one landing shall be located 610-760 mm (24-30 in.) below the stationary water level. Exception: In wading pools, the sloped entry and landings, if provided, shall extend to the deepest part of the wading pool; and
- incorporate two *handrails* complying with 1.1.7, with a *clear* width of 840-965 mm (33-38 in.) between.

Wading pool access shall be safe and gradual, so a child or a caregiver with a *disability* can independently access or be assisted into the water easily and/or use a wheelchair to enter.

RELATED SECTIONS

All relevant parts of Sections 1.0 General Design Standards, 2.0 Exterior Design Standards and 3.0 Interior Design Standards.

GENERAL STANDARDS

1.4.2 Public Historic Places

RATIONALE

Providing people of all ages, interests and capacities with broad, general access to *public historic places* is a highly desirable social goal. It is important to ensure that such access is accompanied by adequate psychological comfort and dignity. Many users of *public historic places* are the same demographic market that is growing older, becoming less mobile, and often has compromised hearing and vision.

Design solutions that best balance accessibility needs with heritage values are those that enhance the use and appreciation of a property for everyone. Work should be carefully planned and undertaken so that damage to the heritage value and character-defining elements of a public historic place is minimized. The objective is to provide the highest level of access with the lowest level of impact. To determine the most appropriate solutions to access problems, it is recommended that accessibility and conservation specialists, as well as affected users, be consulted early in the planning process. The planning process should begin with an evaluation of the current strengths and weaknesses of the *public historic place* to identify the quality of existing means of access and *wayfinding* tools.

APPLICATION

The City of Winnipeg owns and occupies a variety of *public his-*

toric places, many of which are listed. They include but are not limited to former city halls, early office towers, theatres, swimming pools, fire/paramedic and ambulance stations, and libraries. Workplaces, services and facilities must be adapted so that persons with *disabilities* can participate in society equitably, and with dignity. For *alterations* to all *public historic places*, the Historic Building Committee is required to review the proposal for compliances with the 'Standards and Guidelines for the Conservation of Historic Places in Canada'.

DESIGN REQUIREMENTS

In the 'Standards and Guidelines for the Conservation of Historic Places in Canada', the following recommendations are proposed for accessibility upgrades to historic places. Please refer to the entire document for further detail.

- Identify the heritage value of the historic place and character-defining *elements* - materials, forms, location, spatial configurations, uses and cultural associations or meanings - so that required accessibility modifications will not damage or destroy them.
- Comply with accessibility requirements in such a way that character-defining elements are conserved and heritage value maintained.
- Work with accessibility and conservation specialists and affected users to determine the most appropriate solu-

tion to access problems that will have the least impact on character-defining elements and overall heritage value.

- Provide accessibility that promotes independence for the *disabled* person to the highest degree practicable, while conserving the heritage value and character-defining elements.
- Adapt the intervention to its anticipated lifespan, so that short-term improvements remain as reversible as possible.
- Find solutions to meet accessibility requirements that minimize the impact on the historic place and its environment.

RELATED SECTIONS

All relevant parts of Sections 1.0 General Design Standards, 2.0 Exterior Design Standards and 3.0 Interior Design Standards.

1.4.3 Fixed Seating Assembly Facilities

RATIONALE

Designated viewing areas are required for individuals unable to use typical seating. Viewing areas need to provide adequate *space* to maneuver a mobility device as large as a scooter and should not be limited to one location. Designated companion seating should also be provided. *Guards* placed around a viewing area should not interfere with the line of sight of someone sitting in a wheelchair. A choice of locations and ticket price range should be available. There should be seating options for families with a member who is *disabled*, to sit together as a family. Ensure that wheelchair seating does not block sight lines for others.

APPLICATION

In places of assembly with fixed seating, *accessible* wheelchair locations shall comply with this section and shall be provided in numbers as indicated by Table 1.4.3.1.

In addition, 1%, but not less than one, of all fixed seats shall accommodate guide dogs and be located close to the *access aisle*. A sign or marker shall identify each of the seats. *Signage* notifying patrons of the availability of such seats shall be posted at the ticket office.

In addition, 1%, but not less than one, of all fixed seats shall be aisle seats with no armrests

on the aisle side, or shall have removable or folding armrests on the aisle side. A sign or marker shall identify each of the seats. *Signage* notifying patrons of the availability of such seats shall be posted at the ticket office.

DESIGN REQUIREMENTS

Accessible wheelchair locations shall adjoin an *accessible route* complying with Section 1.1.3 Accessible Routes, Paths and Corridors, without infringing on *egress* from any row of seating or any aisle requirement.

Each *accessible* wheelchair location shall be

- an integral part of any

Number of Fixed Seats in Seating Area	Number of Spaces Required for Wheelchairs
2-100	2
101-200	3
201-300	4
301-400	5
401-500	6
501-900	7
901-1300	8
1301-1700	9
each increment of up to 400 seats in excess of 1700	One additional space

Table 1.4.3.1 Wheelchair Viewing Locations

1.4 GENERAL CONTEXT SPECIFIC REQUIREMENTS

GENERAL STANDARDS

1.4.3 Fixed Seating Assembly Facilities (continued)

seating plan. Seats shall be distributed in a manner that provides people with physical *disabilities* a choice of admission prices and lines of sight comparable to those for members of the general public;

- *clear* and level, or level with removable seats;
- if the wheelchair enters from a side approach, not less than 920 mm (36 in.) wide and 1525 mm (60 in.) long;
- if the wheelchair enters from a front or rear approach, not less than 920 mm (36 in.) wide and 1370 (54 in.) long;
- arranged so that at least two designated wheelchair locations are side by side;
- arranged so that at least one companion fixed seat is provided next to each wheelchair seating area; and
- where the seating capacity exceeds 100, provided in more than one location

RELATED SECTIONS

- 1.1.1 Space and Reach Requirements
- 1.1.2 Protruding and Overhead Objects
- 1.1.3 Accessible Routes, Paths and Corridors
- 1.2.1 Texture, Finishes and Colour
- 1.2.2 Acoustics
- 1.2.3 Public Address Systems
- 1.2.4 Signage
- 2.1.1 Exterior Ground Surfaces
- 3.1.1 Interior Floor Surfaces

1.4.3 Fixed Seating Assembly Facilities (continued)

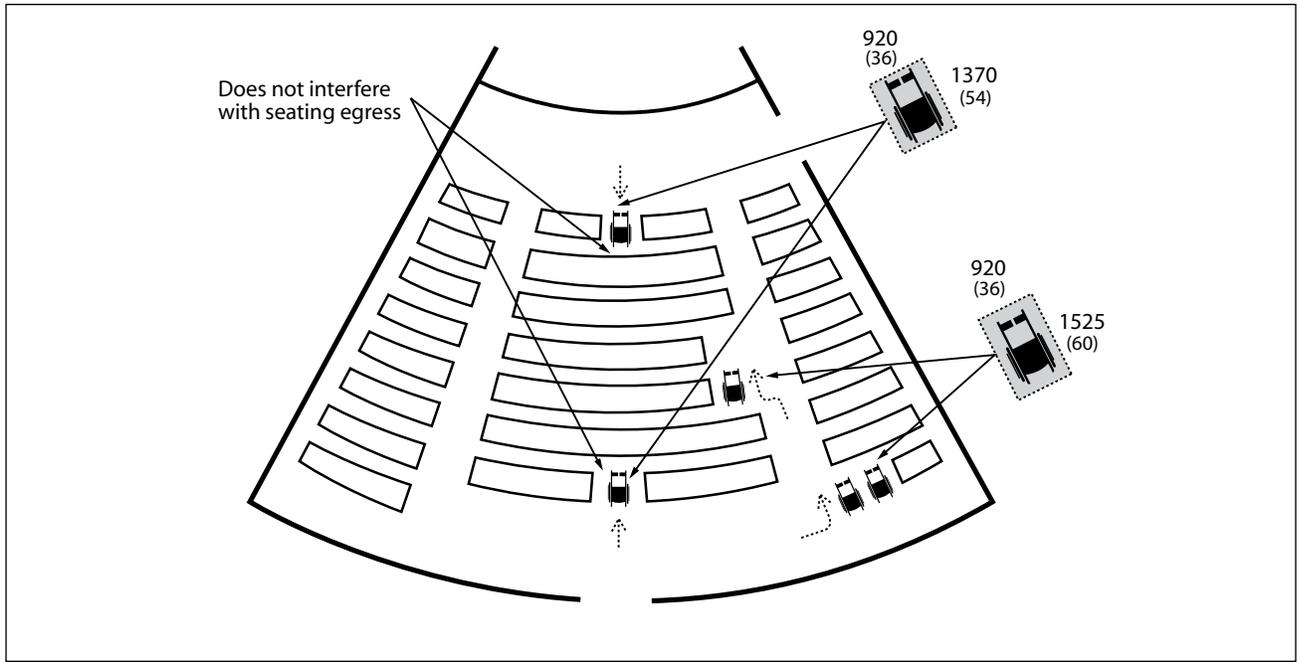

Figure 1.4.3.1 Distribution of Wheelchair Locations

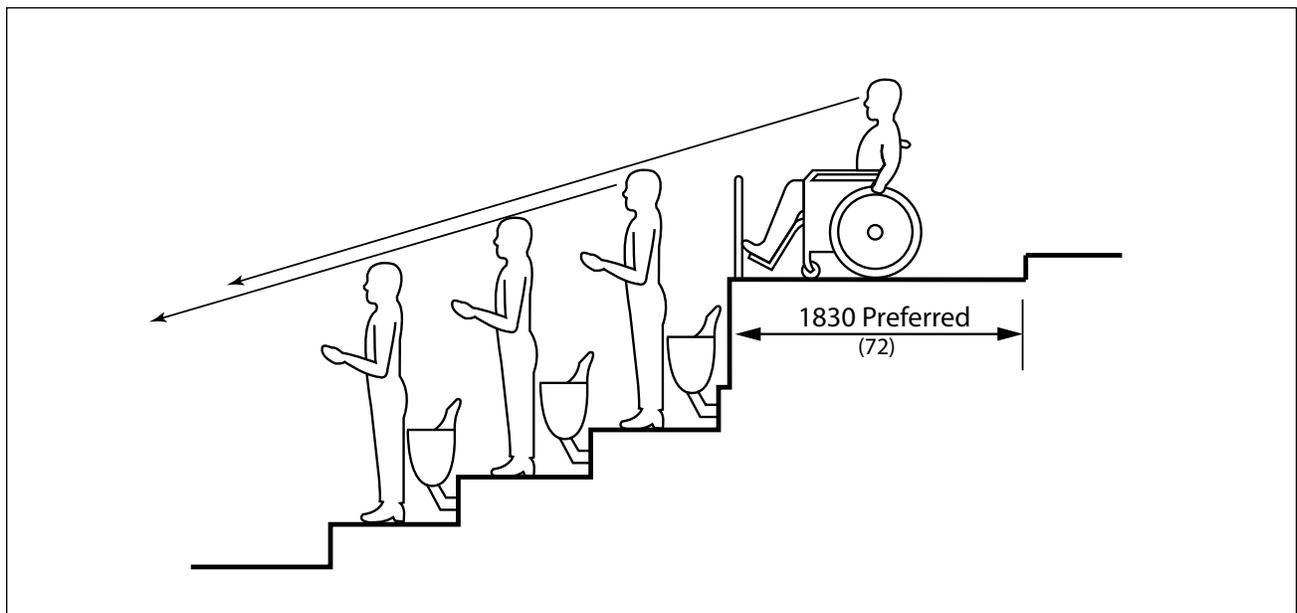
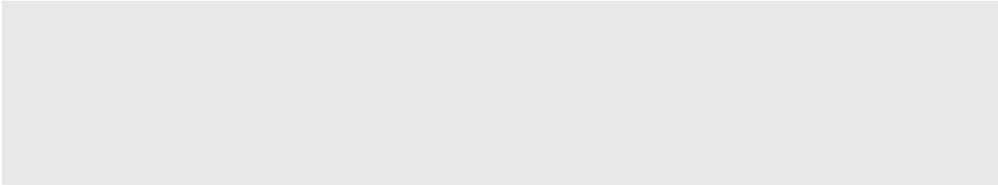
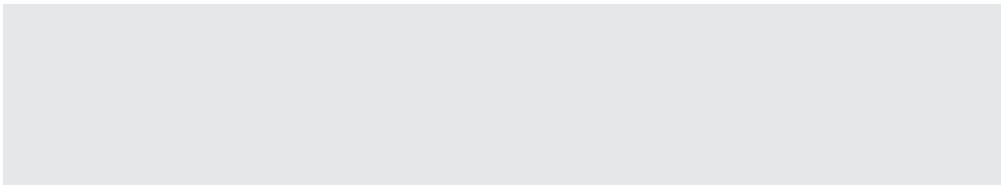

Figure 1.4.3.2 Sight Lines at Wheelchair Viewing Locations

1.4 GENERAL CONTEXT SPECIFIC REQUIREMENTS





EXTERIOR STANDARDS

EXTERIOR STANDARDS

2.1.1 Exterior Ground Surfaces

RATIONALE

The selection of ground materials can be critical to the safe and easy movement of persons using all kinds of mobility aids, as well as persons with low vision.

Irregular surfaces, such as cobblestones or pea-gravel are difficult for either walking or pushing a wheelchair. Slippery surfaces are hazardous to all individuals and especially for seniors and others who may not be sure-footed.

Small and uneven changes in surface level represent a further barrier to using a wheelchair but also present a tripping hazard to ambulatory persons. Openings in grates or grilles can catch canes or wheelchair wheels.

APPLICATION

Ground surfaces along all routes shall comply with this section.

DESIGN REQUIREMENTS

Sidewalk *accessible routes* shall be concrete. Pavers shall not be used in an *accessible route* unless avoidance is *technically not feasible*.

Where *technically not feasible*, asphalt, compacted gravel screenings, interlocking brick and patio stones may be used.

The use of interlocking brick and patio stones is discouraged within the *clear path of travel*.

Pavers may be used as secondary surfacing (in patios, furniture zones etc.) or to delineate the concrete *accessible route*.

Where interlocking pavers are used they must be installed on a stable base that is not susceptible to movement from frost heave or other factors.

Pavers shall have joint spacing not more than 6 mm (1/4 in.). Exception: Pavers with beveled edges shall have a maximum spacing of 13 mm (1/2 in.) between the edges of the bevel on the top surface of the pavers.

Suitable surfaces for outdoor pedestrian trails include asphalt, concrete and well-compacted

limestone or shale screenings.

Wood chip use must be limited to low use trails where accessibility signage is provided for difficulty rating.

Steps shall be finished with a non-slip, non-glare material and incorporate highly contrasted nosings.

Ramp surfaces shall be firm and non-slip.

Ground surfaces shall be stable, firm, slip resistant and glare-free.

Ground surfaces shall not be heavily patterned.

Changes in level, except for elevators and other elevating

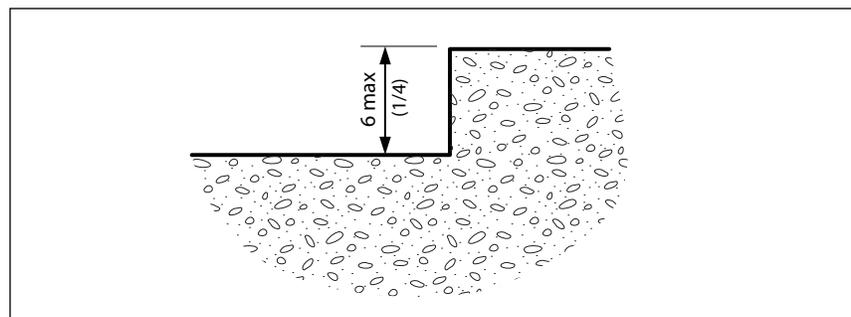

Figure 2.1.2.1 Changes in Level

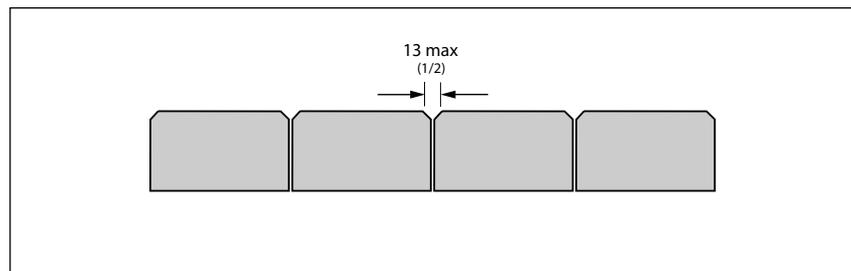

Figure 2.1.2.2 Joint Spacing in Pavers

2.1.1 Exterior Ground Surfaces (continued)

devices, shall conform to Table 2.1.1.1 and Figure 2.1.2.1.

Catch basins, hydro vaults, man-hole covers or drainage inlets shall

- not be located in the *accessible route*; and
- be relocated if already existing in an *accessible route*.

If relocation of an existing catch basin, tree grate or drainage inlet is *technically not feasible*, the grate and inlet cover shall

- have spaces not greater than 13 mm (1/2 in.) wide in one direction; and
- be placed so that the long dimension is perpendicular to the dominant direction of travel (See Figure 2.1.2.2)

RELATED SECTIONS

- 1.1.3 Accessible Routes, Paths and Corridors
- 1.1.5 Ramps
- 1.1.6 Stairs
- 1.2.1 Texture, Finishes and Colour
- 1.2.6 Detectable Warning Surfaces
- 2.1.3 Streetscape
- 2.1.5 Curb Ramps and Truncated Dome Detectable Warning Surfaces

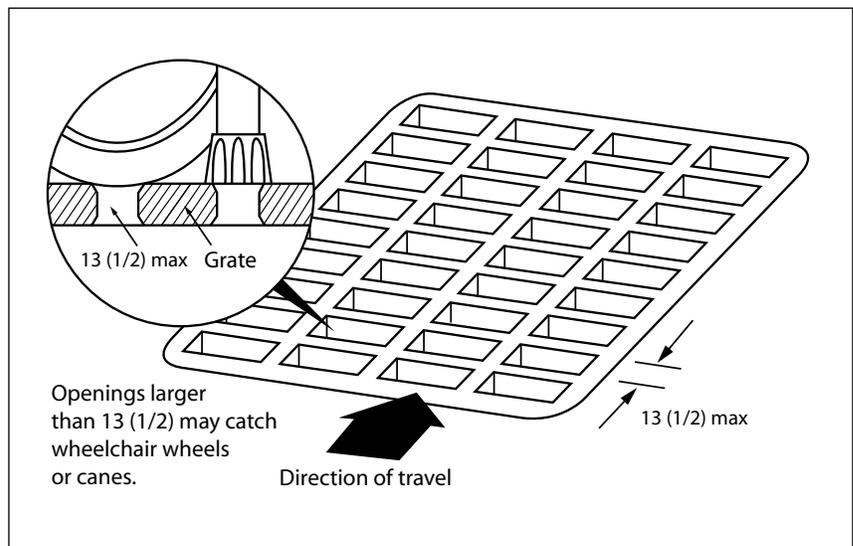

Figure 2.1.1.3 Grills and Gratings

Vertical Rise	Edge Treatment
0 to 6 mm (0 - 1/4")	May be vertical
Over 6 mm (over 1/4")	Treat as a sloped surface, <i>ramp</i> or <i>curb ramp</i>

Table 2.1.1.1 Changes in Ground Level

2.1 EXTERIOR ACCESS AND CIRCULATION

2.1.1 Exterior Ground Surfaces (continued)

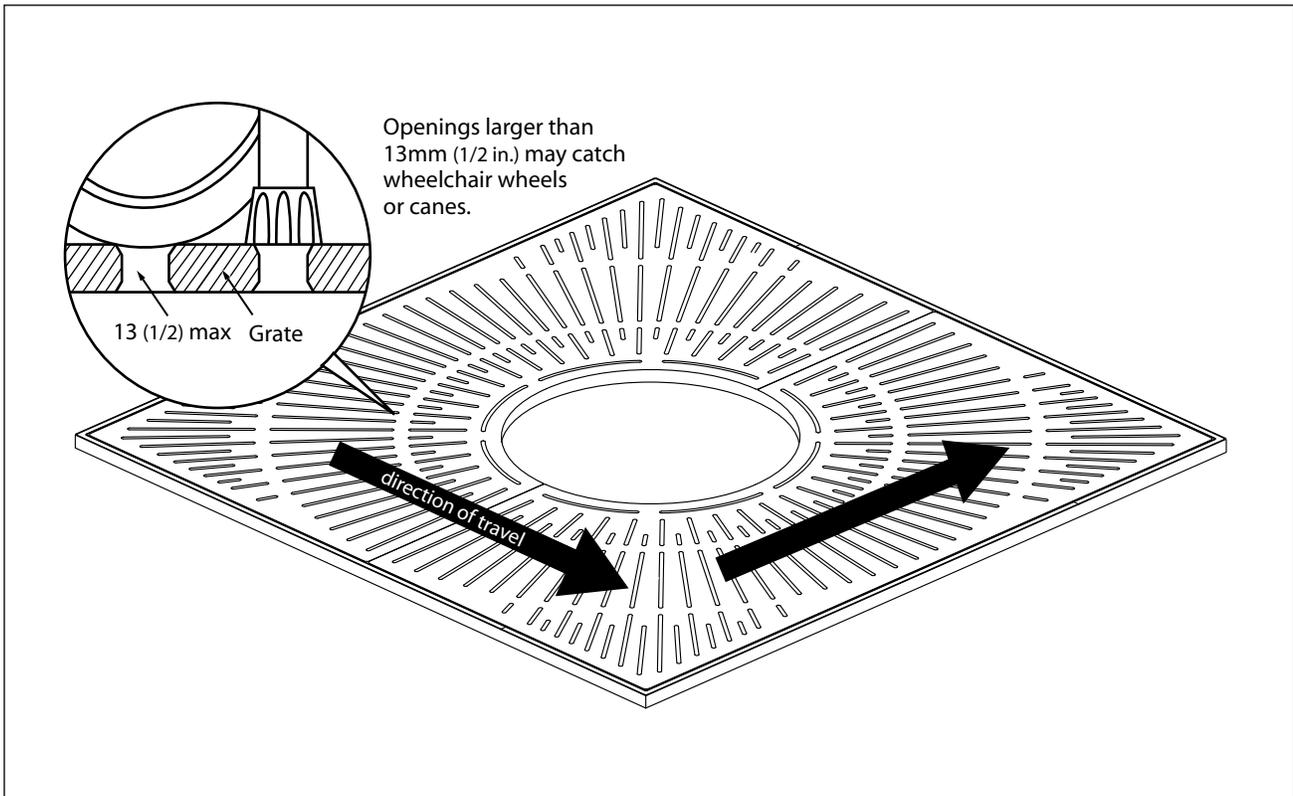

Figure 2.1.1.4 Example of an Accessible Tree Grate

2.1.2 Exterior Lighting

RATIONALE

Artificial lighting and natural light sources should provide comfortable, evenly distributed light at all working areas, in all circulation routes and in all areas of potential hazard. Also, outdoor lighting should be provided at *entrances*, along frequently used access routes and at frequently used outdoor amenities.

APPLICATION

Exterior lighting systems shall comply with this section.

DESIGN REQUIREMENTS

Exterior lighting shall be in compliance with the 'Illuminating Engineering Society of North America Standards' in all public thoroughfares, and at all pedestrian routes, to provide safe access for persons with *disabilities* from sidewalks, bus stops and parking areas to nearby *facilities* and amenities.

At pedestrian *entrances*, lighting levels should be minimum 100 lux (9.4 ft-candles) consistently over the *entrance* area, measured at the ground. Public entrances require a fuller spectrum of light ≥ 84 CRT.

Over frequently used pedestrian routes, including walkways, paths, stairs and *ramps*, lighting levels shall be minimum 5 lux (.5 ft-candles) consistently over the route, measured at the ground.

At frequently used *accessible* parking *spaces* and limited mobility *spaces*, lighting levels shall be minimum 5 lux (.5 ft-candles) for parking lots and 10 lux (1 ft-candle) for parking garages, measured at the ground.

Lighting levels at passenger drop-off areas shall be minimum 30 lux (3 ft-candles) consistently over the drop-off area, measured at the ground.

At frequently used steps and stairs, lighting shall be located at or beside the steps or stairs, to clearly define the treads, risers and nosings.

All lighting shall

- provide a good colour spectrum; and
- be evenly distributed to minimize cast shadows.

Supplementary lighting shall be provided to highlight key *signage* and orientation landmarks.

Low-level lighting shall be high enough to *clear* normal snow accumulation.

Lighting fixtures shall comply with the relevant parts of Sections 1.1.2 Protruding and Overhead Objects and 2.1.3 Streetscape.

RELATED SECTIONS

All relevant parts of Sections 1.0 General Design Standards, 2.0 Exterior Design Standards and 3.0 Interior Design Standards.

EXTERIOR STANDARDS

2.1.3 Streetscape

RATIONALE

Maintaining a clear path of travel is important to all individuals using pathways and sidewalks. Unless properly located, *street elements* such as newspaper boxes, waste receptacles, benches, outdoor patios and bus shelters present a barrier to all pedestrians, especially those that require additional *space* for use of wheelchairs, scooters, strollers or delivery carts.

For persons with a vision *impairment*, unidentified obstructions within pathways and sidewalks can present a hazard.

Clear path of travel should always consist of a smooth, solid surface such as asphalt or concrete.

Outdoor patios encroaching on pedestrian pathways and sidewalks must incorporate railings that are easily distinguished both visually and by cane.

The efficient and thorough removal of snow and ice are also essential to outdoor pathways. Negotiating a wheelchair or stroller through a snow covered path is exceptionally difficult. Icy surfaces are hazardous to all pedestrians, especially individuals such as senior citizens that may not be sure-footed.

Benches can provide a resting place for an individual with difficulty in walking distances. Such furniture should incorporate strong *colour contrasts* and be located off pathways, to minimize potential as an obstruction.

APPLICATION

Street elements, including but not limited to, waste receptacles, light standards, signs, planters, mail boxes, vending machines, benches, traffic signals, red-light cameras and utility boxes contained within a *public right-of-way*, shall comply with this section, including *street elements* that are located inside or outside of *facilities*.

DESIGN REQUIREMENTS

Where sidewalks are provided as part of the *public right-of-way*, within the Winnipeg Downtown Core Area, an *accessible route* at least 1900 mm (59 in.) wide shall be maintained along the sidewalk.

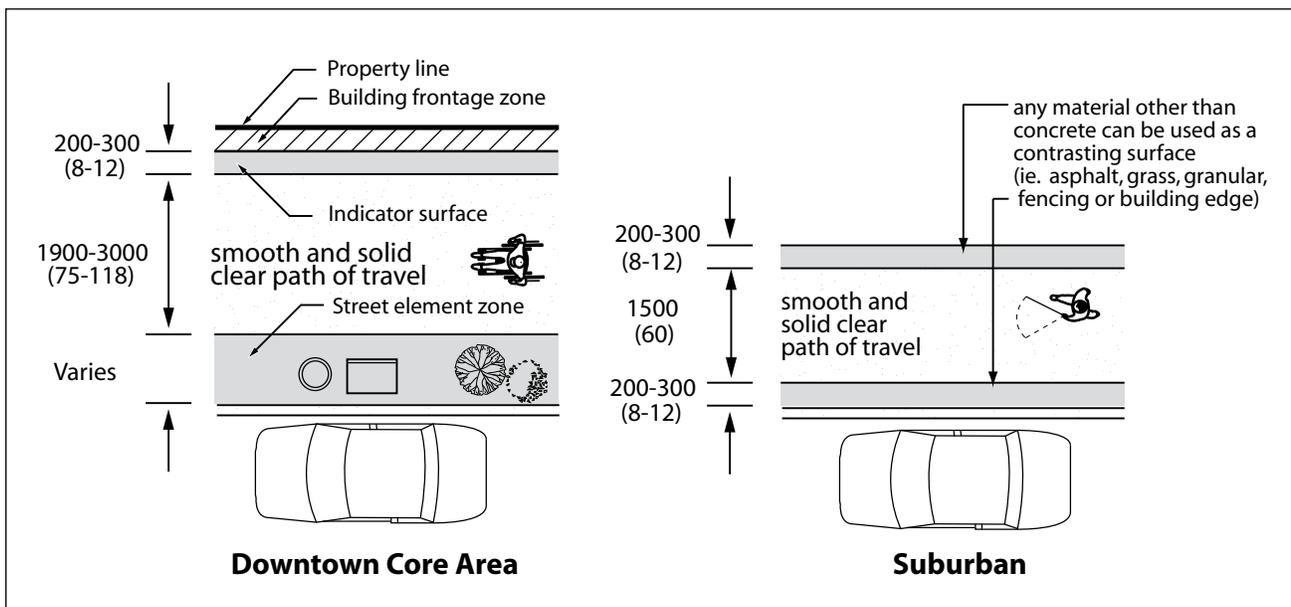

Figure 2.1.3.1 Arterial and Collector Sidewalks

2.1.3 Streetscape (continued)

Where sidewalks are provided as part of the *public right-of-way*, outside Winnipeg's downtown core area as per Winnipeg Zoning By-Law 200-2006, an *accessible route* at least 1500 mm (72 3/4 in.) wide shall be maintained along the sidewalk. This includes a clear path of travel of 1500 mm (59 in.) in.) and an indicator surface of 200 – 300 mm (7 13/16 in. - 11 13/16 in.) in width on either side of the *clear path of travel*.

Clearances along *accessible routes* within *public rights-of-way* must comply with Sections 1.1.2 Protruding and Overhead Objects, 1.1.3 Accessible Routes, Paths and Corridors and 2.1.1 Exterior Ground Surfaces.

Street elements shall

- be consistently located within the *street element zone* of the *accessible route*;
- where the *street element zone* is not identified with indicator surfaces, individual *street elements* they must be *cane-detectable*, in compliance with Section 1.1.2 Protruding and Overhead Objects; and
- be securely mounted.

Street elements shall incorporate *colour contrast* to differentiate them from the surrounding environment.

Waste receptacles and recycling bins in *accessible* open areas, such as *parks*, wilderness areas, beaches or picnic areas, shall be mounted on firm, level pads adjacent to the path or sidewalk

(but not directly beside seating areas).

Waste receptacles and recycling bins shall be clearly identified by suitable lettering, in compliance with the relevant parts of Section 1.2.4 Signage.

Where lids or openings are provided on waste receptacles and recycling bins, they shall be mounted no higher than 1060 mm (42 in.) above the adjacent floor or ground surface. Opening mechanisms shall comply with Section 3.5.1 Controls and Operating Mechanisms.

On-street letter boxes and community letter boxes shall

- be located immediately adjacent to an *accessible route*;

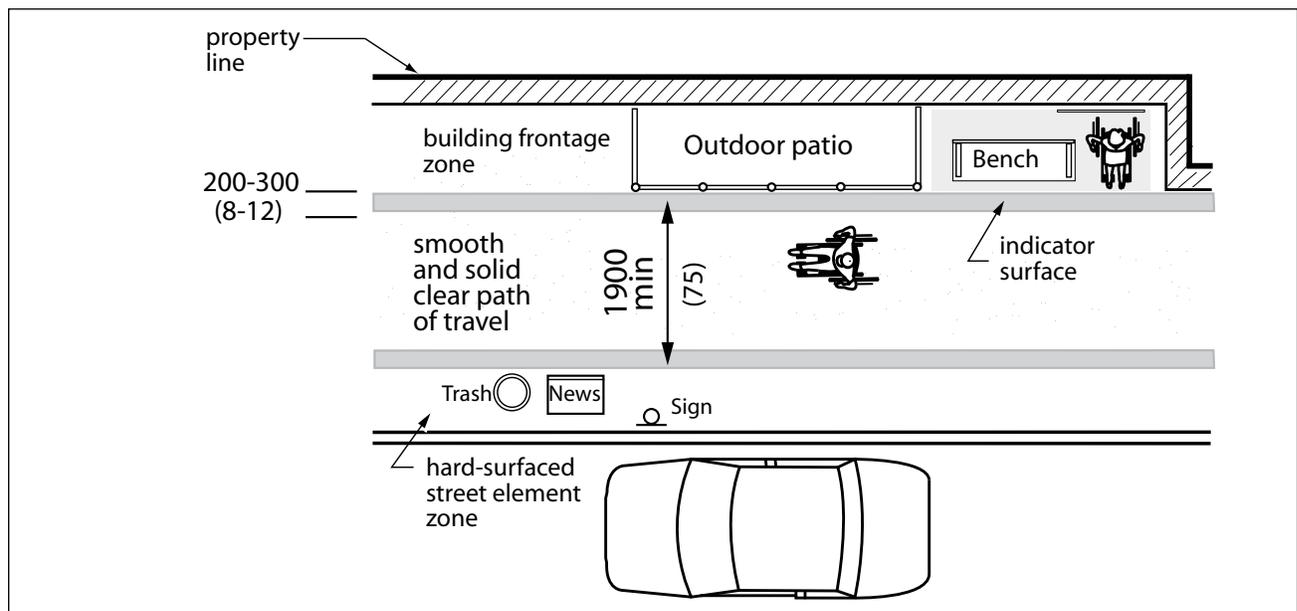

Figure 2.1.3.2 Downtown Core Area Streetscape

EXTERIOR STANDARDS

2.1.3 Streetscape (continued)

- incorporate a *clear* area at least 760 mm (30 in.) wide x 1370 mm (54 in.) long in front of usable parts;
 - ensure the *clear area* can be accessed from the adjacent *accessible* route in compliance with Section 1.1.3 Accessible Routes, Paths and Corridors;
 - where provided, have slots for posting mail located to be reachable from a seated position;
 - where provided, have at least 10%, but no less than one, mailbox for collecting mail, located to be reachable from a seated position;
 - have operating mechanisms in compliance with Sections 3.5.1 Controls and Operating Mechanisms; and
 - be kept clear of snow.
- 2.2.1 Balconies, Plazas and Patios
 - 2.2.3 Picnic Tables
 - 2.3.1 Parking
 - 2.3.2 Passenger Loading Zones

RELATED SECTIONS

- 1.1.1 Space and Reach Requirements
- 1.1.2 Protruding and Overhead Objects
- 1.1.3 Accessible Routes, Paths and Corridors
- 1.2.1 Texture, Finishes and Colour
- 1.2.4 Signage
- 1.2.6 Detectable Warning Surfaces
- 1.3.3 Public Telephones
- 1.3.6 Benches
- 2.1.1 Exterior Ground Surfaces
- 2.1.2 Exterior Lighting
- 2.1.5 Curb Ramps and Truncated Dome Detectable Warning Surfaces

2.1.4 Traffic Signal Poles

RATIONALE

Persons who use mobility devices such as wheelchairs and scooters need to be able to reach and use the pushbuttons that control pedestrian signals at crosswalks. Access issues include the provision of appropriate space beside the pushbuttons, as well as the button configuration and mounting height.

Where practical, all poles should be lined up with existing above ground elements.

APPLICATION

In new construction, where traffic signal poles with pushbuttons are provided to control pedestrian access to crosswalks, they shall comply with this section (retrofits will comply where possible).

DESIGN REQUIREMENTS

Signal poles with pushbuttons to control pedestrian access to crosswalks shall be

- adjacent to an *accessible route* complying with Section 1.1.3 Accessible Routes, Paths and Corridors;
- unobstructed from the location of crossing;
- parallel to the direction of the crosswalk controlled by the pushbutton;
- 300-500 mm (11-3/4 - 19-5/8 in.) from the lowest edge of the *curb ramp* ; and
- 800-1500 mm (31-1/2 - 59 in.) from the back of the curb

line. Note: The ideal location for the signal pole is 1000 mm (39-3/8 in.) from the back of the curb line.

Pushbuttons mounted on signal poles shall be

- be mounted 914 mm (36 in.) +/- 25 mm (1 in.) above the sidewalk grade for approach;
- incorporate a painted yellow square or reflective tape on the post behind the activation button, that is at least twice the size of the push-button enclosure; and
- be operable
 - using one hand; and
 - with a force of less than 13 N (3 lbf.).

Where there are two pedestrian signals on the same corner, the push-buttons shall be mounted on poles separated by at least 3000 mm (118 in.). Refer to Figure 2.1.4.1.

Exception: If the requirements for separation cannot be met, two *accessible* pedestrian signal-related buttons may be installed on a single pole. The traffic signal pole shall be placed in the middle of the two *curb ramps*. If two push-buttons are installed on the same pole, the *accessible* pedestrian signals shall be equipped to provide two sound messages facing the crosswalk that has the walk signal indication. Refer to Figure 2.1.4.2.

RELATED SECTIONS

- 1.1.1 Space and Reach Requirements
- 1.1.2 Protruding and Overhead Objects
- 1.1.3 Accessible Routes, Paths and Corridors
- 1.2.1 Texture, Finishes and Colour
- 1.2.6 Detectable Warning Surfaces
- 2.1.1 Exterior Ground Surfaces
- 2.1.3 Streetscape
- 2.1.5 Curb Ramps and Truncated Dome Detectable Warning Surfaces
- 3.1.1 Interior Floor Surfaces

EXTERIOR STANDARDS

2.1.4 Traffic Signal Poles (continued)

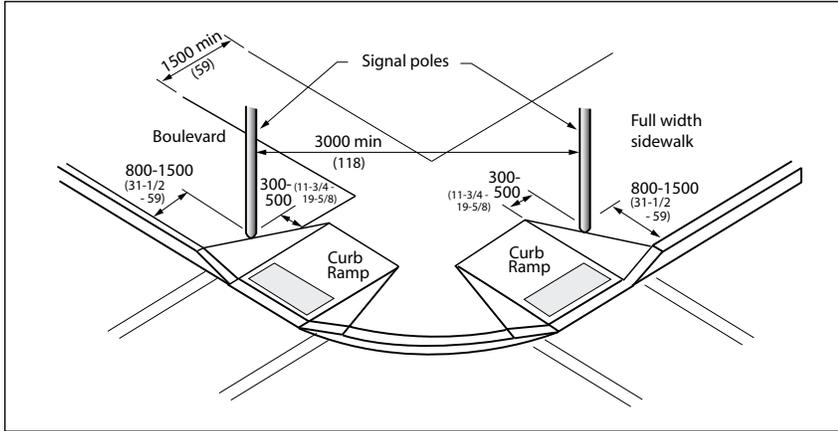

Figure 2.1.4.1 Corner with Two Traffic Signal Poles

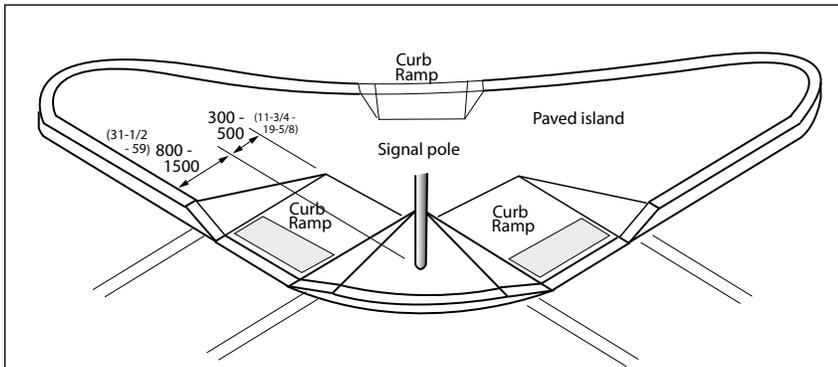

Figure 2.1.4.2 Corner with One Traffic Signal Pole

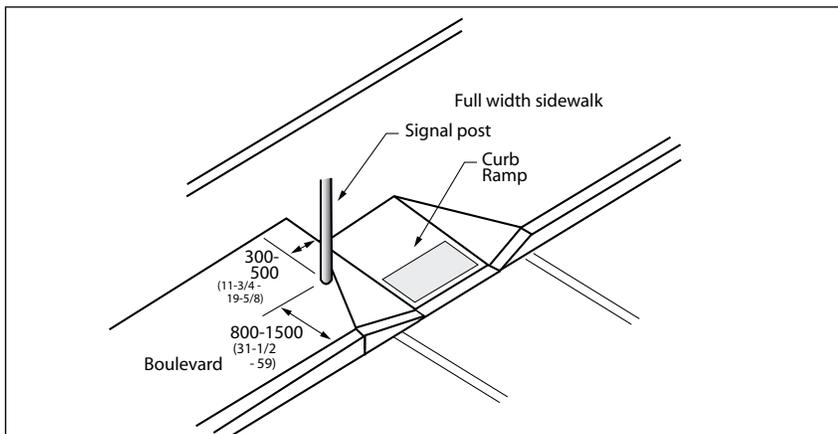

Figure 2.1.4.3 Mid-Block Crossing with One Traffic Signal Pole

2.1.5 Curb Ramps and Truncated Dome Detectable Warning Surfaces

RATIONALE

In the interest of moving people safely and efficiently on and off road, the design of *curb ramps* is very important. The same issues related to the slopes of *ramps* apply equally to slopes of *curb ramps*.

A well-designed *curb ramp* can be spoiled by an uneven or gapped transition between the road surface and *curb ramp*. Flared sides on the *curb ramp* eliminate the hazard of pedestrians stepping off of an edge. While a smooth transition and minimal slope are ideal for someone in a wheelchair, they are a potential hazard to an individual with a vision *impairment* who may not notice the transition from sidewalk to *street*. *Truncated dome detectable warning surfaces* become an important safety feature in this scenario.

Snow accumulation at *curb ramps* shall be minimized throughout the winter months.

APPLICATION

Curb ramps complying with this section shall be provided whenever any path of travel crosses a curb.

DESIGN REQUIREMENTS

Accessible curb ramps shall be on an *accessible route* complying with Section 1.1.3 Accessible Routes, Paths and Corridors.

The *ramp slope* shall be between

1:50 and 1:20 (2%-5%). *Curb ramps* with a *ramp slope* steeper than 1:20 (5%) must be approved by the Contract Administrator.

The minimum width of *curb ramps*, exclusive of flared sides, shall be 1500 mm (59 in.), except where the alternate curb ramp configuration is used. Refer to Figure 4.1.10.2. The alternate curb ramp may have a reduced sidewalk width at the top of the curb ramp of 1220 mm (48 in.) for level maneuvering/turning space.

Curb ramp configuration shall be as illustrated in Figures 4.1.10.1 to 4.1.10.7.

Truncated dome detectable warning surfaces should be installed in accordance with the most current Public Works E-specifications.

Truncated dome detectable warning surfaces shall be yellow in colour and shall be orientated perpendicular to the direction of the pedestrian crossing and the curb ramp across the *street*.

When used in an intersection, the detectable warning surface shall align directionally with the warning surface and curb ramp across the *street* to signify the start and end point of a travel way crossing.

The maximum crossfall of gutters and road surfaces immediately adjacent to *curb ramps* shall be 1:20 (5%).

Surfaces of *curb ramps* shall

- be slip-resistant; and

- incorporate a *detectable warning* surface.

Curb ramps at pedestrian crosswalks shall be wholly contained within the area designated for pedestrian use.

Where possible provide dedicated area for snow piling from all *curb ramps*, away from pedestrian routes. Remove windrows on heavily travelled pedestrian routes.

RELATED SECTIONS

- 1.1.1 Space and Reach Requirements
- 1.2.1 Texture, Finishes and Colour
- 1.2.6 Detectable Warning Surfaces
- 2.1.1 Exterior Ground Surfaces
- 2.1.3 Streetscape
- 3.1.1 Interior Floor Surfaces
- 3.5.4 Interior Glare and Light Sources

2.1.5 Curb Ramps and Truncated Dome Detectable Warning Surfaces (continued)

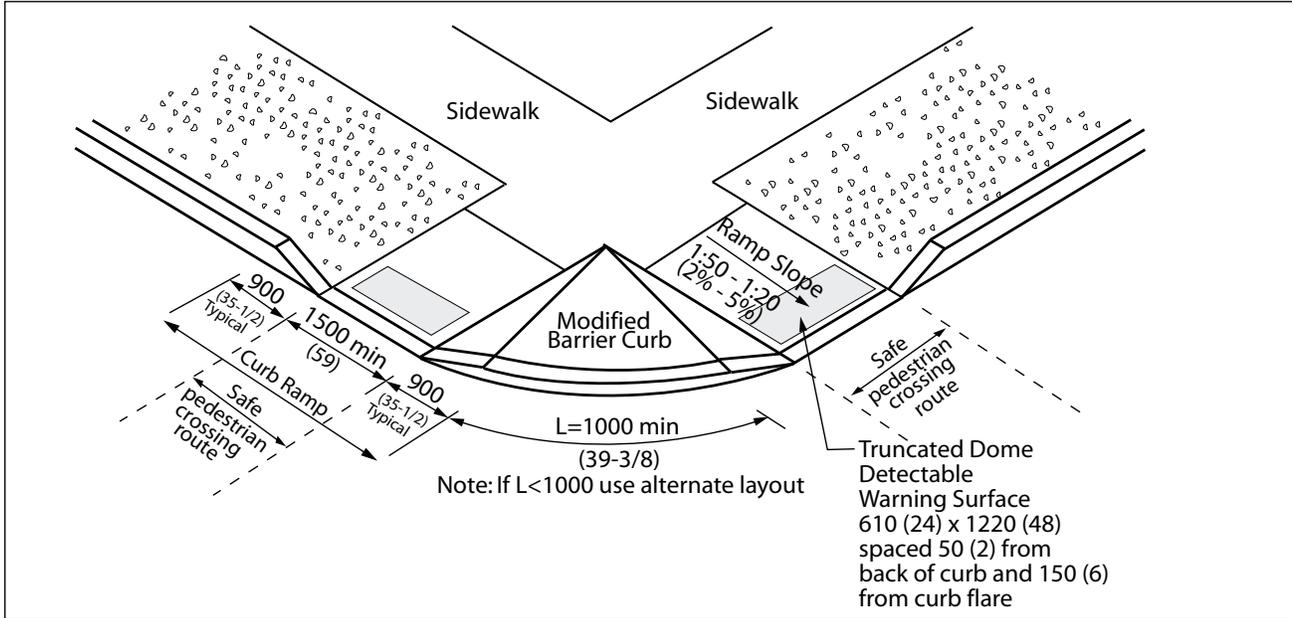

Figure 2.1.5.1 Standard Curb Ramp

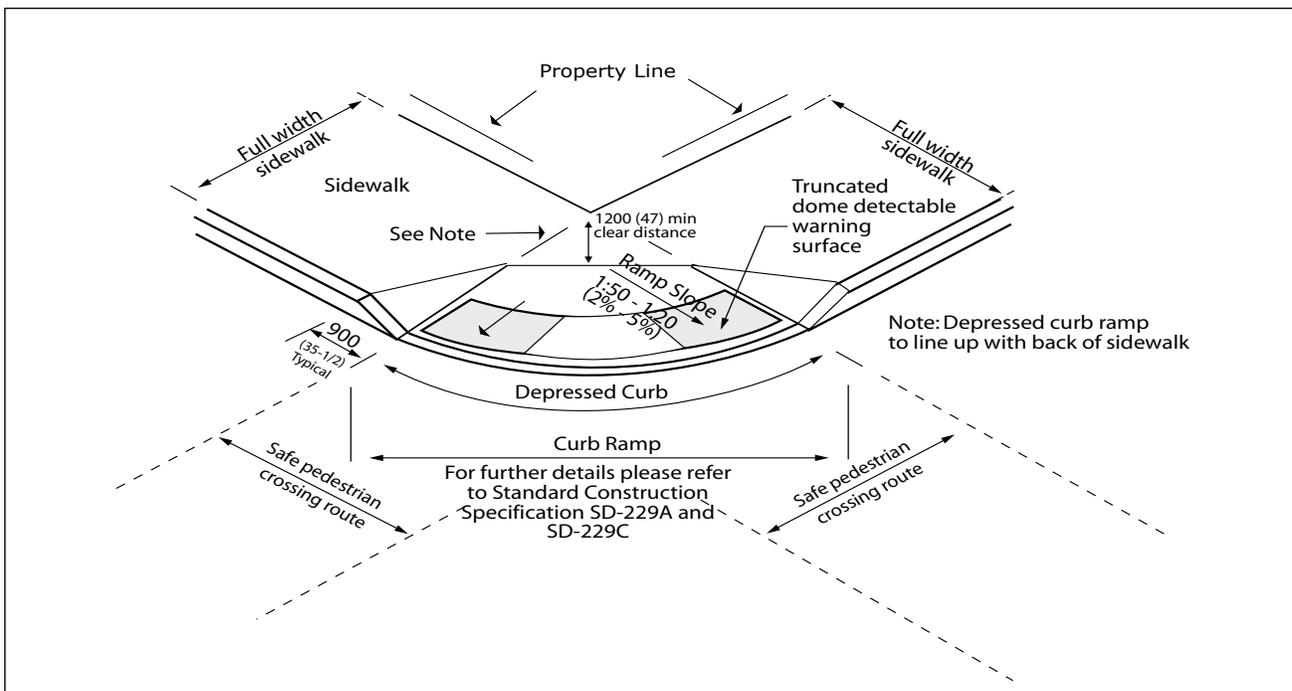

Figure 2.1.5.2 Alternate Curb Ramp

2.1.5 Curb Ramps and Truncated Dome Detectable Warning Surfaces (continued)

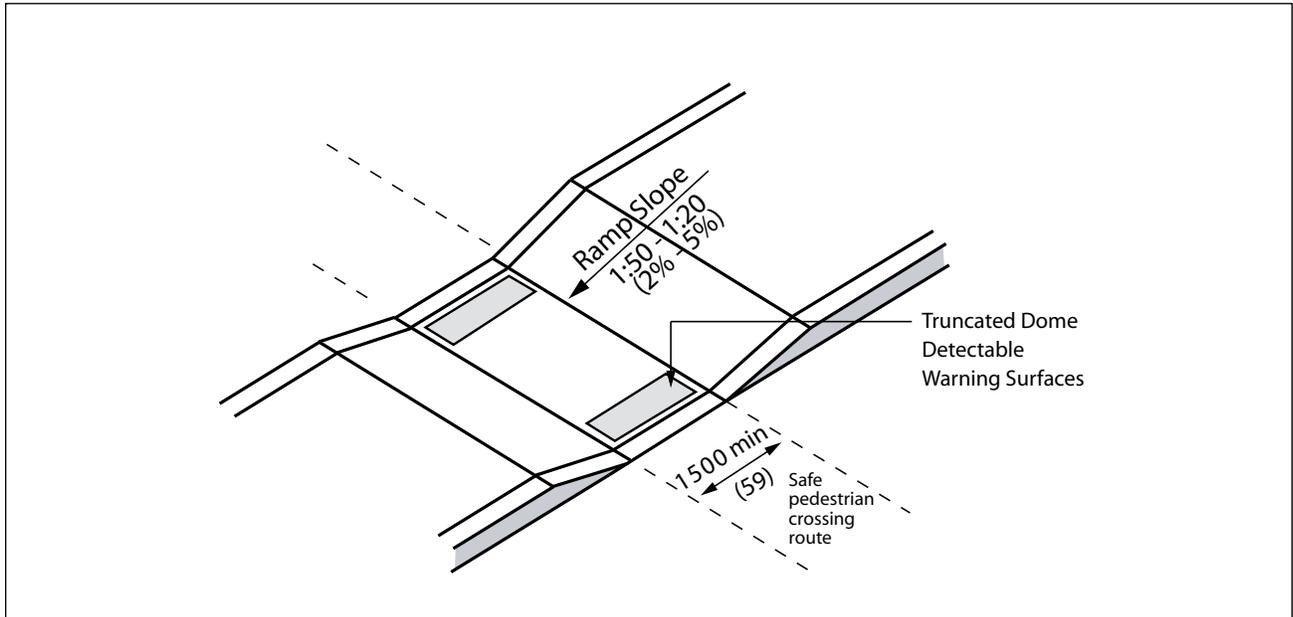

Figure 2.1.5.3 Curb Ramp at Narrow Median Sidewalk Crossing

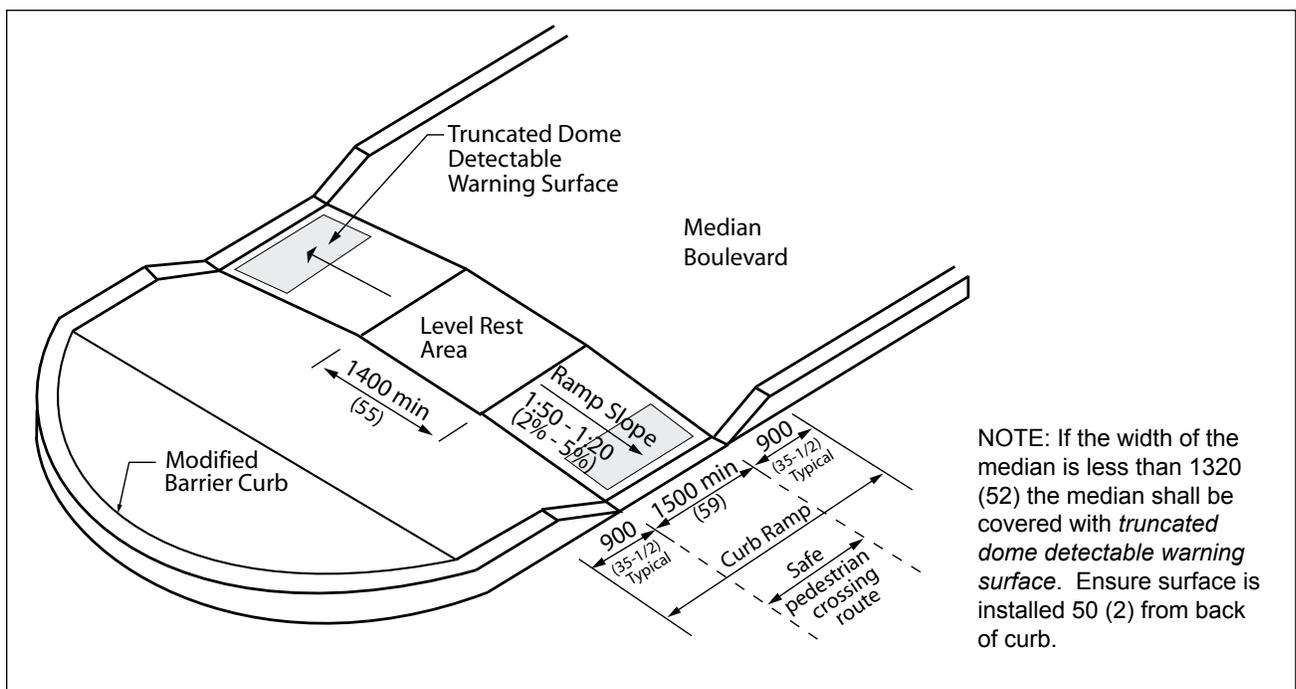

Figure 2.1.5.4 Curb Ramp at Wide Median Sidewalk Crossing

2.1 EXTERIOR ACCESS AND CIRCULATION

2.1.5 Curb Ramps and Truncated Dome Detectable Warning Surfaces (continued)

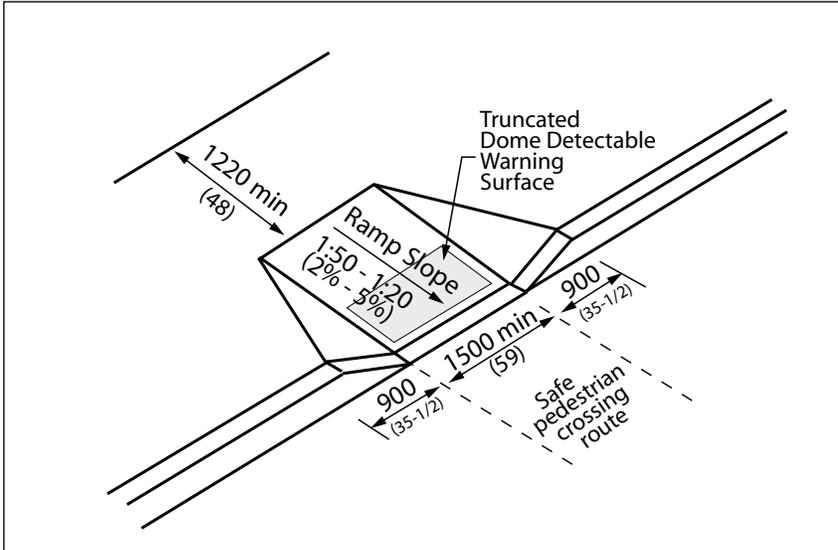

Figure 2.1.5.5 Curb Ramp at Marked Pedestrian Crosswalks

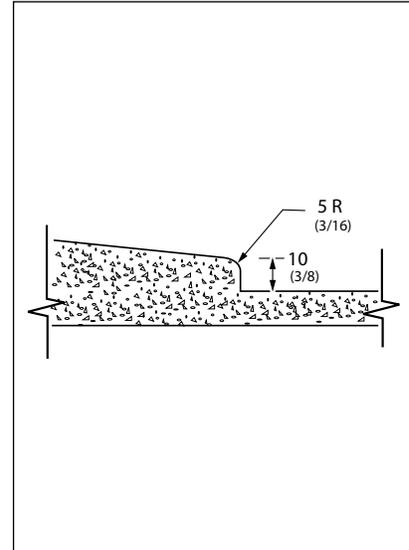

Figure 2.1.5.6 Curb Ramp Depressed Curb

**** Refer to the most current Public Works E-specifications for installation of truncated dome detectable warning surfaces .**

2.2.1 Balconies, Plazas and Patios

RATIONALE

Where a number of balconies, patios or plazas are provided, it is desirable to consider options for different levels of sun and wind protection. This is of benefit to individuals with varying tolerances for sun or heat. Doors to these *spaces* typically incorporate large expanses of glazing. These should be appropriately marked to increase their visibility. Thresholds at balcony doors should be avoided.

APPLICATION

Balconies, plazas and patios provided for use by the general public, clients, customers or employees shall comply with this section.

DESIGN REQUIREMENTS

Balconies and plazas shall

- be located on an *accessible route* complying with Section 1.1.3 Accessible Routes, Paths and Corridors; and
- have a minimum depth of 2440 mm (96 in.).

Patios and plazas shall

- not restrict the *clear* width of adjacent sidewalks or other access routes. Refer to Section 2.1.3 Streetscape and to the City of Winnipeg Encroachment ByLaw No. 692/94.

Exterior balconies, plazas and patios, where directly *accessible* from the interior *spaces*, shall incorporate a threshold in compliance with Section 3.5.1 Controls and Operating Mechanisms.

Balcony, plaza and patio surfaces shall

- comply with Section 2.1.1 Exterior Ground Surfaces;
- be sloped to ensure removal of water; and
- be sloped no more than 1:50 (2%).

Railings and *guards* at balconies, plazas and patios shall

- comply with the requirements of the *MBC*; and
- be designed to allow *clear* vision below the rail for persons seated in wheelchairs;
- incorporate pronounced *colour contrast* between the railings and *guards* from the surrounding environment; and
- where located adjacent to an *accessible route*, incorporate a *cane-detectable element*, no more than 100 mm (4 in.) above the surface of the *accessible route*.

Where located adjacent to an *accessible route* patio umbrellas shall not overhang into the *accessible route* unless an overhead clearance in compliance with Figure 1.1.2.3 can be

achieved.

Doors opening out onto balconies or patios shall be located to open against a side wall or rail.

RELATED SECTIONS

- 1.1.1 Space and Reach Requirements
- 1.1.3 Accessible Routes, Paths and Corridors
- 1.2.1 Texture, Finishes and Colour
- 2.1.1 Exterior Ground Surfaces
- 2.1.3 Streetscape
- 3.1.1 Interior Floor Surfaces

2.2 EXTERIOR AMENITIES

2.2.1 Balconies, Plazas and Patios (continued)

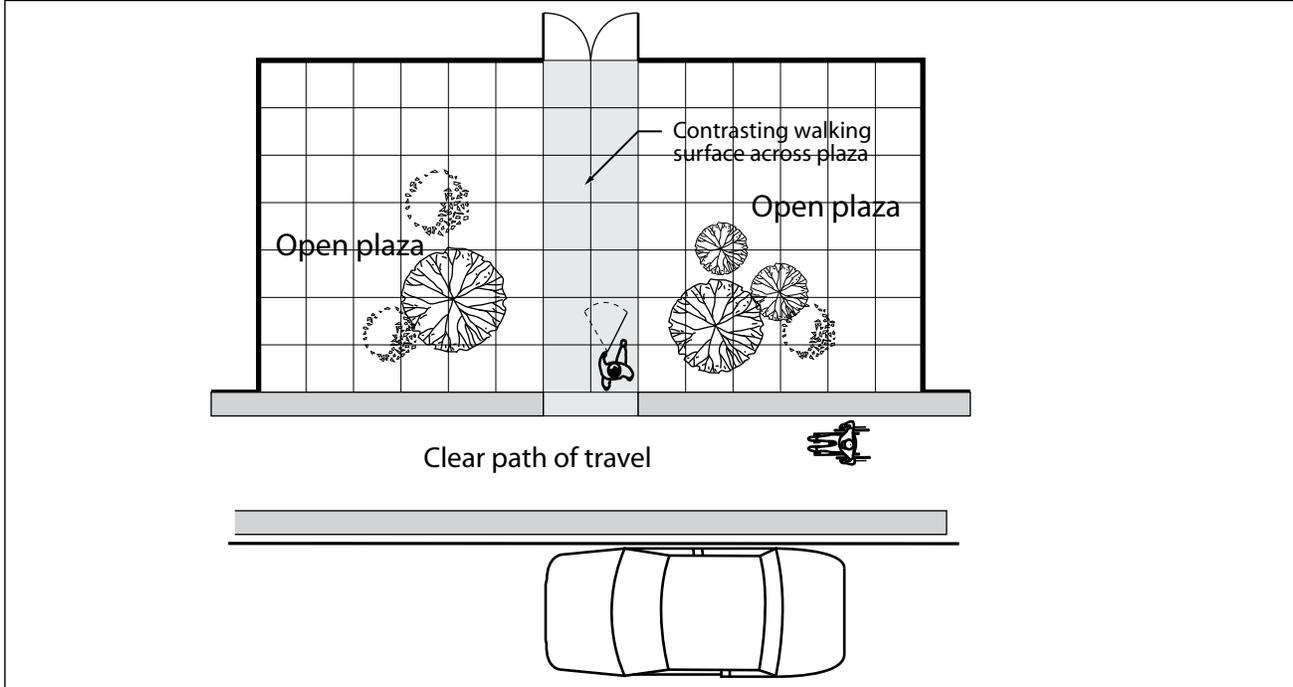
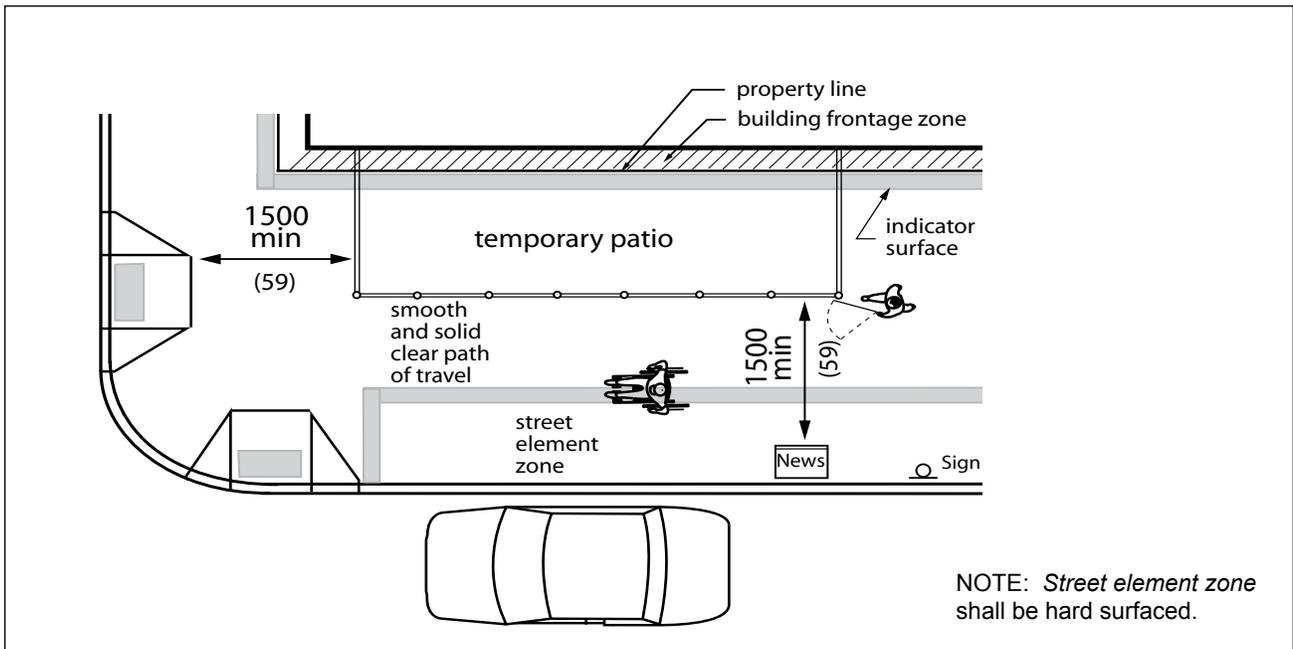

Figure 2.2.1.1 Pathway Across Open Plaza



NOTE: *Street element zone shall be hard surfaced.*

Figure 2.2.1.2 Temporary Patio in a Public Right-of-Way

2.2.1 Balconies, Plazas and Patios (continued)

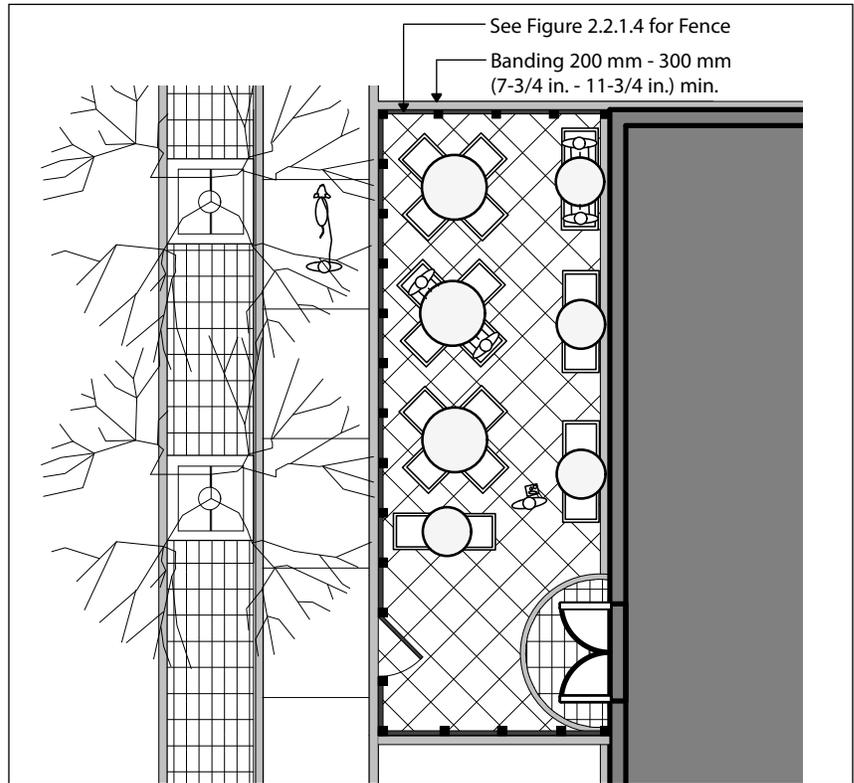

Figure 2.2.1.3 Permanent Patio in a *Public Right-of-Way*

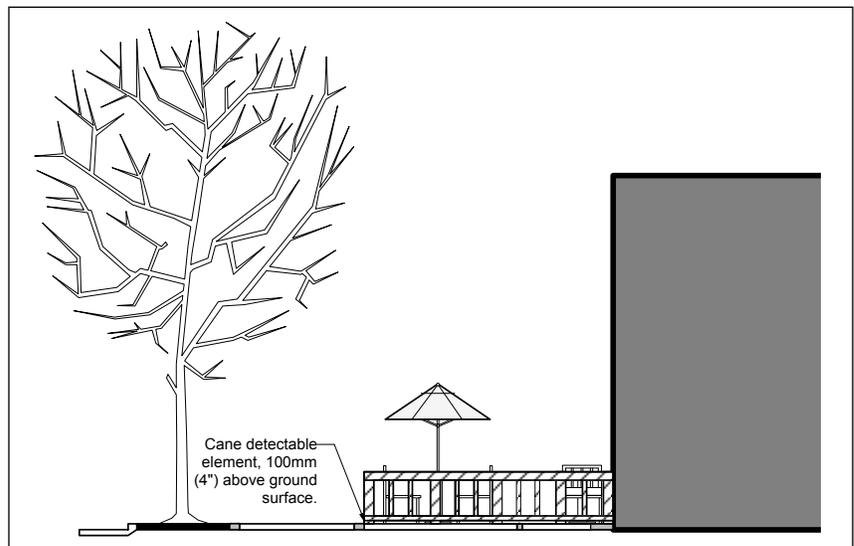

Figure 2.2.1.4 Permanent Patio in a *Public Right-of-Way*

2.2 EXTERIOR AMENITIES

2.2.2 Plantings

RATIONALE

Trees, shrubs and other plants should be selected and located with a wide variety of users in mind. Fragrant plants can provide orientation cues for individuals with vision *impairments*. *Colour contrasting* plant material near walkways can be helpful as a guide. A row of hedges along one side of a walkway can provide edge definition and straight-line orientation for individuals with vision *impairments*.

Good maintenance of planting is as important as good design. Plants that drop large seeds and/or fruit can present slipping hazards, as well as difficulties for pushing a wheelchair. Plants that overhang pathways can impede all users and be a particular hazard to individuals with vision *impairments*.

APPLICATION

Landscape *elements* and plantings beds contained within the *site* shall comply with this section.

Where plant beds or community gardens are provided for gardening use 10% of the area of the plant beds, but not less than one, shall comply with this section. It is preferable to have all plant beds comply with this section.

DESIGN REQUIREMENTS

Accessible community gardens shall be

- raised a minimum of 460 mm (18 in.) and a maximum of 865 mm (34 in.) above the adjacent floor or ground surface; and
- located on a solid surface adjacent to an *accessible route* complying with Section 1.1.3 Accessible Routes, Paths and Corridors.

Shrubs with thorns and sharp edges shall be maintained such that they do not encroach upon the *clear path of travel*.

Plants that drop large seeds and fruit such as apple trees, ornamental crab trees, and acorns from oak trees, shall not overhang or be positioned near *accessible* paths or walkways.

Guy wires shall not be used in any area which is intended for use by the general public, clients, customers or employees, unless the guy wires are protected by a *cane-detectable* barrier.

Tree *guards* shall conform to Sections 1.1.2 Protruding and Overhead Objects and 1.1.3 Accessible Routes, Paths and Corridors, and tree grates will conform to Section 2.1.1 Exterior Ground Surfaces.

Overhanging branches of trees or shrubs over walkways or paths shall not reduce the available headroom at any part of the *walkway* or path to less than 2500 mm (98 1/2 in.).

RELATED SECTIONS

- 1.1.1 Space and Reach Requirements
- 1.1.2 Protruding and Overhead Objects
- 1.1.3 Accessible Routes, Paths and Corridors
- 1.2.1 Texture, Finishes and Colour
- 1.2.6 Detectable Warning Surfaces
- 2.1.1 Exterior Ground Surfaces
- 2.1.3 Streetscape
- 3.1.1 Interior Floor Surfaces

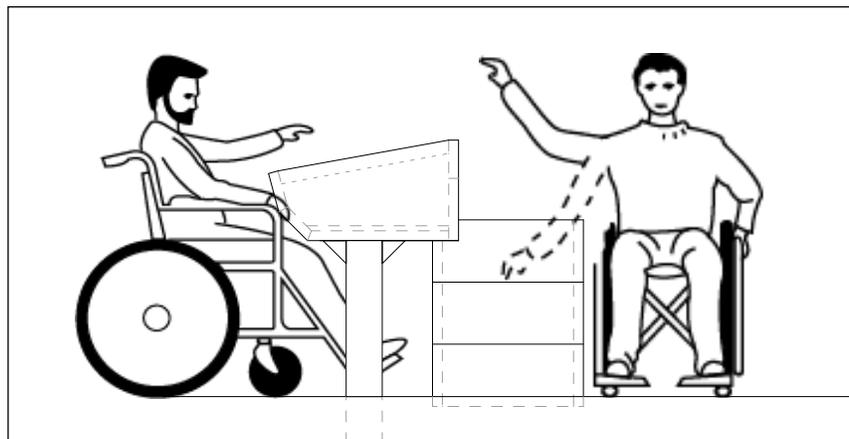

Figure 4.3.16.1 Example of an *Accessible* Planting Bed

2.2.3 Picnic Tables

RATIONALE

Picnic tables with an extension of the table surface make them *accessible* to persons using wheelchairs. A firm, level surface around the table, with an *accessible* path leading to the table, is required for wheelchair accessibility. A change in texture from a pathway to the picnic table area is an important cue for an individual with a vision *impairment*.

APPLICATION

If picnic tables are provided in an *accessible* public or *common*

use area, at least 10%, but not less than one, for each cluster of picnic tables shall comply with this section. It is preferable to have all picnic tables comply with this section.

DESIGN REQUIREMENTS

Accessible picnic tables shall

- be adjacent to an *accessible route* complying with Section 1.1.3 Accessible Routes, Paths and Corridors;
- have *knee space* under the table at least 760 mm (30 in.) wide by 500 mm (19 5/8 in.)

deep and 700 mm (27 1/2 in.) high;

- be of contrasting colour to their background; and
- have a level, firm ground surface extending at least 2440 mm (96 in.) on two sides of the table and at least 1220 mm (48 in.) on the other sides.

The top of *accessible* picnic tables shall be from 710 mm (28 in.) to 850 mm (33 1/2 in.) above the finished floor or ground.

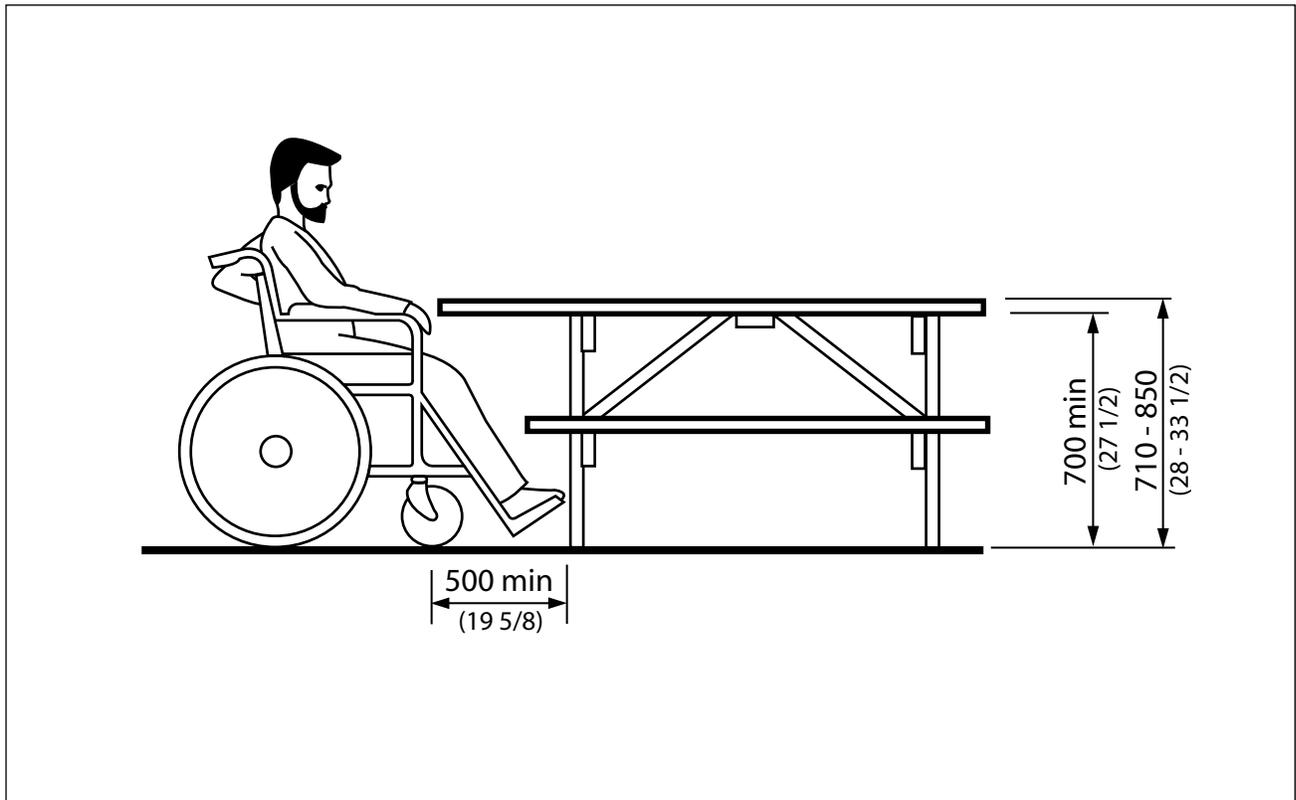

Figure 2.2.3.1 Picnic Table Requirements

2.2.3 Picnic Tables (continued)

RELATED SECTIONS

- 1.1.1 Space and Reach Requirements
- 1.1.2 Protruding and Overhead Objects
- 1.1.3 Accessible Routes, Paths and Corridors
- 1.2.1 Texture, Finishes and Colour
- 1.2.6 Detectable Warning Surfaces
- 2.1.1 Exterior Ground Surfaces
- 2.1.3 Streetscape

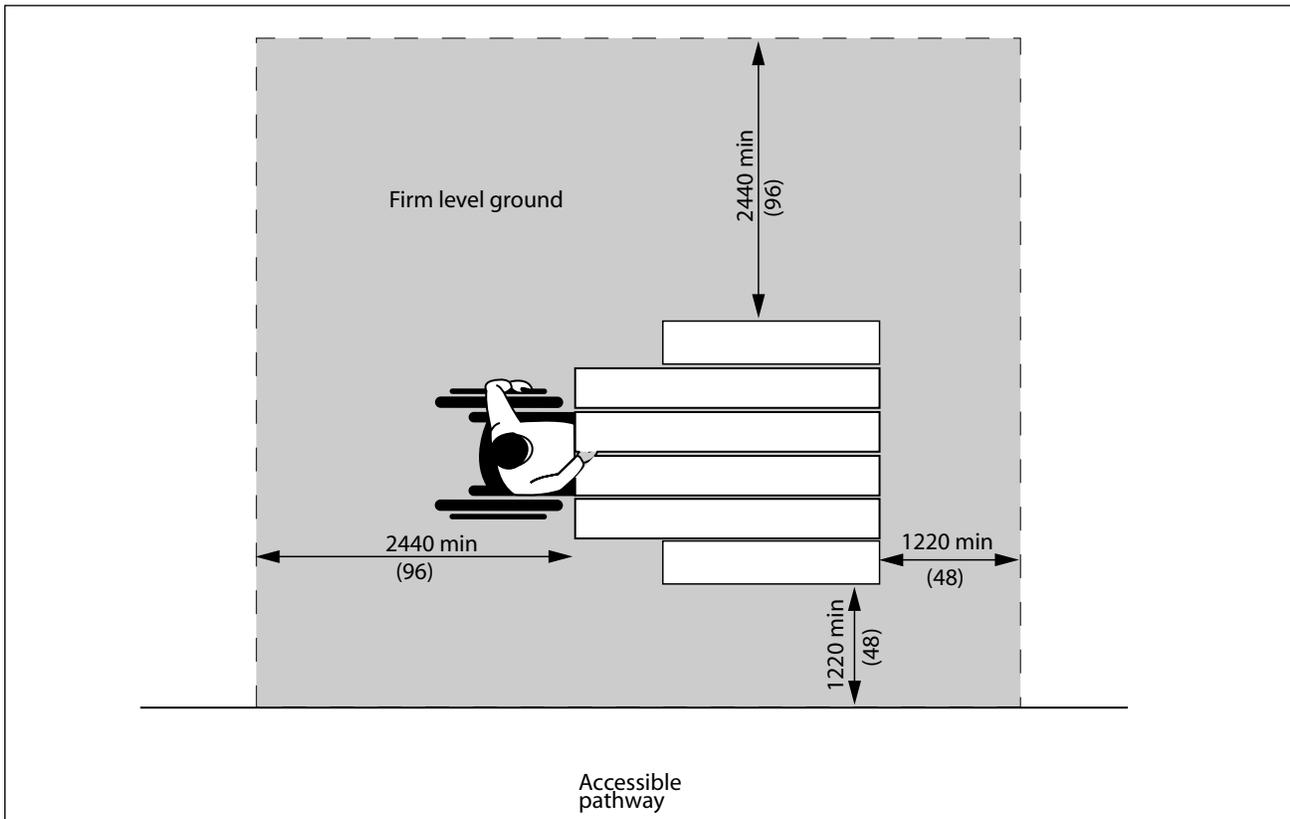

Figure 2.2.3.2 Space Requirements Around Picnic Tables

2.2.4 Dog Relief Areas

RATIONALE

Persons who are vision impaired and use a dog to assist with mobility, as well as other persons with working companion dogs, require access to an area for their dogs to relieve themselves. Such dog relief areas need to be in an *accessible* location, feature good drainage and a garbage can for waste disposal.

APPLICATION

Dog relief areas shall be provided in *buildings* of assembly occupancy which incorporate a meeting space for 50 or more people.

Dog relief areas shall comply with this section.

DESIGN REQUIREMENTS

Dog relief areas shall

- be adjacent to an *accessible route* complying with Section 1.1.3 Accessible Routes, Paths and Corridors;
- be located within 30 metres (98 ft. 5 in.) of an *accessible entrance*;
- be an unobstructed, dedicated space at least 1500 x 1500 mm (59 x 59 in.) in size;
- incorporate a ground surface with drainage (Note: grass is preferable to gravel);
- incorporate an accessible garbage can; and
- be located away from busy traffic areas such as access routes and loading docks.

RELATED SECTIONS

- 1.1.3 Accessible Routes, Paths and Corridors
- 2.1.3 Streetscape

2.2 EXTERIOR AMENITIES

EXTERIOR STANDARDS

2.3.1 Parking

RATIONALE

The provision of parking *spaces* near the *entrance* to a facility is important to accommodate persons with a variety of *disabilities*. *Disabling* conditions such as arthritis or heart conditions, using crutches or pushing a wheelchair, all make it difficult to travel long distances. Minimizing travel distances is particularly important outdoors where weather conditions and ground surfaces can make travel both difficult and hazardous. The *accessible route* of travel connecting the parking to the *entrance* should be well marked and free of steps and curbs.

In addition to the proximity to *entrances*, the spatial requirements of accessible parking *spaces* is important. A person using a mobility aid such as a wheelchair requires a wider parking stall to accommodate the maneuvering of the wheelchair beside the car or van. A van may also require additional *space* to deploy a lift or *ramp* through the side or back door. An individual would then require *space* for the deployment of the lift itself as well as additional *space* to maneuver on/off the lift.

Heights of ceilings or overhead structures along the routes to accessible parking are a factor. Accessible vans may incorporate a raised roof resulting in the need for additional overhead clearance. Alternatively, the floor of the van may be lowered, resulting in lower tolerances for speed bumps

and pavement slope transitions. The number of *accessible parking spaces* required by this section may not be sufficient in some *facilities* (such as seniors' centres) where increased numbers of persons with *disabilities* might be expected.

APPLICATION

This standard is applicable to all new parking structures, on and off-*street* parking and surface parking lots. For existing structures and surface parking lots undergoing renovations/*alterations*, standards should be employed whenever feasible.

The number of parking *spaces* designated to accommodate persons with disabilities shall be in accordance with Table 2.3.1.1.

All designated *spaces* shall be located on the shortest possible circulation route, with minimal traffic flow crossing, to an *accessible facility entrance* (e.g., in lots serving a particular *facility*) or to an *accessible pedestrian entrance* of the parking *facility* (e.g., in lots not serving a particular *facility*).

In *facilities* with multiple *accessible entrances* with adjacent parking, *accessible parking spaces* shall be dispersed and located closest to the *accessible entrances*.

DESIGN REQUIREMENTS

An *accessible route* shall be provided from each *accessible park-*

ing area to an *accessible entrance* into the *facility*.

Accessible off-street parking spaces shall

- be located on and have direct and unobstructed access to an *accessible route* complying with Section 1.1.3 Accessible Routes, Paths and Corridors;
- be at least 2440 mm (96 in.) wide and 6100 mm (240 in.) long;
- have an adjacent *access aisle* at least 2440 mm (96 in.) wide. In a *retrofit* situation where it is *technically not feasible* to provide a 2440 mm (96 in.) *access aisle*, the aisle may be reduced to 2000 mm (78-3/4 in.);
- have a firm, level surface with a maximum of 2% longitudinal grade for drainage;
- where surfaces are paved, have *access aisles* clearly indicated by markings. Refer to Figures;
- have a maximum *cross slope* of 1:50 (2%); and
- have a height clearance of at least 2750 mm (9 ft.) at the parking *space* and along the vehicle access and *egress routes*.

Accessible on-street parking spaces shall

- be located on an *accessible route* complying with Section 1.1.3 Accessible Routes, Paths and Corridors;
- be at least 3900 mm (154 in.) wide and 5400 mm (213 in.)

2.3 EXTERIOR CONTEXT SPECIFIC REQUIREMENTS

2.3.1 Parking (continued)

- long;
- have an *access aisle* behind the vehicle at least 2440 mm (96 in.) wide. In a *retrofit* situation where it is *technically not feasible* to provide a 2440 mm (96 in.) *access aisle*, the aisle may be reduced to 2000 mm (78-3/4 in.);
- have an adjacent clear space crossing the *street element zone* at least 2440 mm (96 in.) wide leading to the

- accessible route;
- have a firm, level surface;
- have a maximum *cross slope* of 2%; and
- have a height clearance of at least 2750 mm (9 ft.) at the parking space and along the vehicle access and egress routes.

Accessible parking spaces shall be designated as being reserved for use by persons with *disabili-*

ties.

Signage of parking spaces shall incorporate the following components:

- a designated *disabled* parking space sign as specified in the 'Manual of Uniform Traffic Control Devices for Canada', mounted vertically; and
- for off-street parking, an international symbol of access

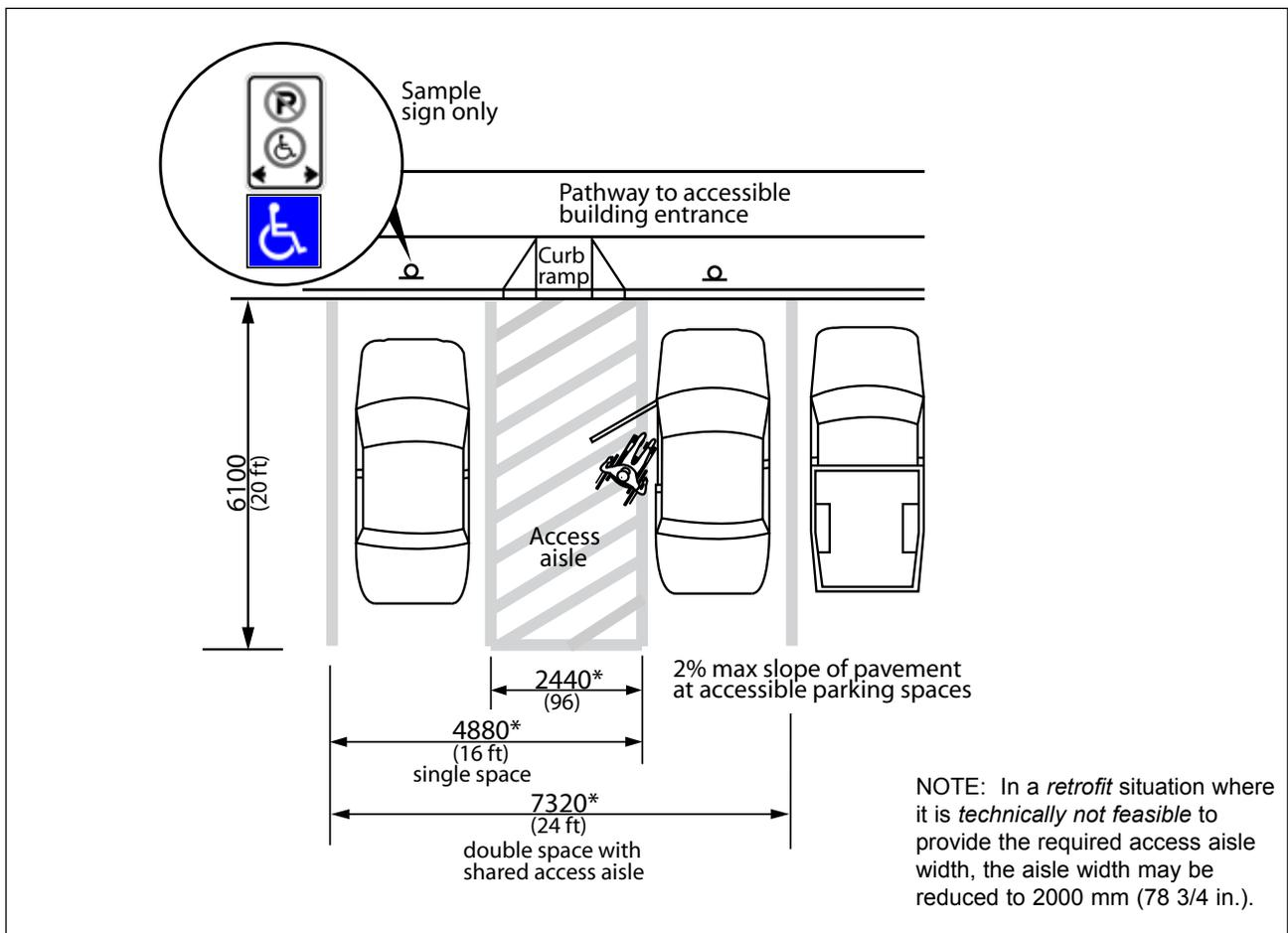

Figure 2.3.1.1 Side-by-side Parking Space

2.3 EXTERIOR CONTEXT SPECIFIC REQUIREMENTS

EXTERIOR STANDARDS

2.3.1 Parking (continued)

on the pavement of the stall.

Vertical parking *space* designation signs shall

- be at least 300 mm (12 in.) wide x 450 mm (18 in.) high; and
- be installed at a height of 2000 mm (78 in.) to 3000 mm (118 in.) from the ground/floor surface to the centre line of the sign.

The symbol of access shall be painted on the pavement of each designated *off-street* parking *space* and shall

- be at least 1000 mm (3'-4")

- long;
- be located in the centre of the *space*; and
- be painted white on a background field of blue.
- Paint used on the surface of parking *spaces* must be slip-resistant.

In multi-level parking *facilities*, signs must be provided indicating the floors that have accessible parking.

RELATED SECTIONS

- 1.1.1 Space and Reach Requirements
- 1.1.2 Protruding and Overhead Objects

- 1.1.3 Accessible Routes, Paths and Corridors
- 1.2.1 Texture, Finishes and Colour
- 1.2.4 Signage
- 1.2.6 Detectable Warning Surfaces
- 1.3.2 Vending and Ticketing Machines
- 2.1.1 Exterior Ground Surfaces
- 2.1.2 Exterior Lighting
- 2.1.3 Streetscape
- 3.1.1 Interior Floor Surfaces
- 2.1.5 Curb Ramps and Truncated Dome Detectable Warning Surfaces
- 3.5.3 Interior Lighting

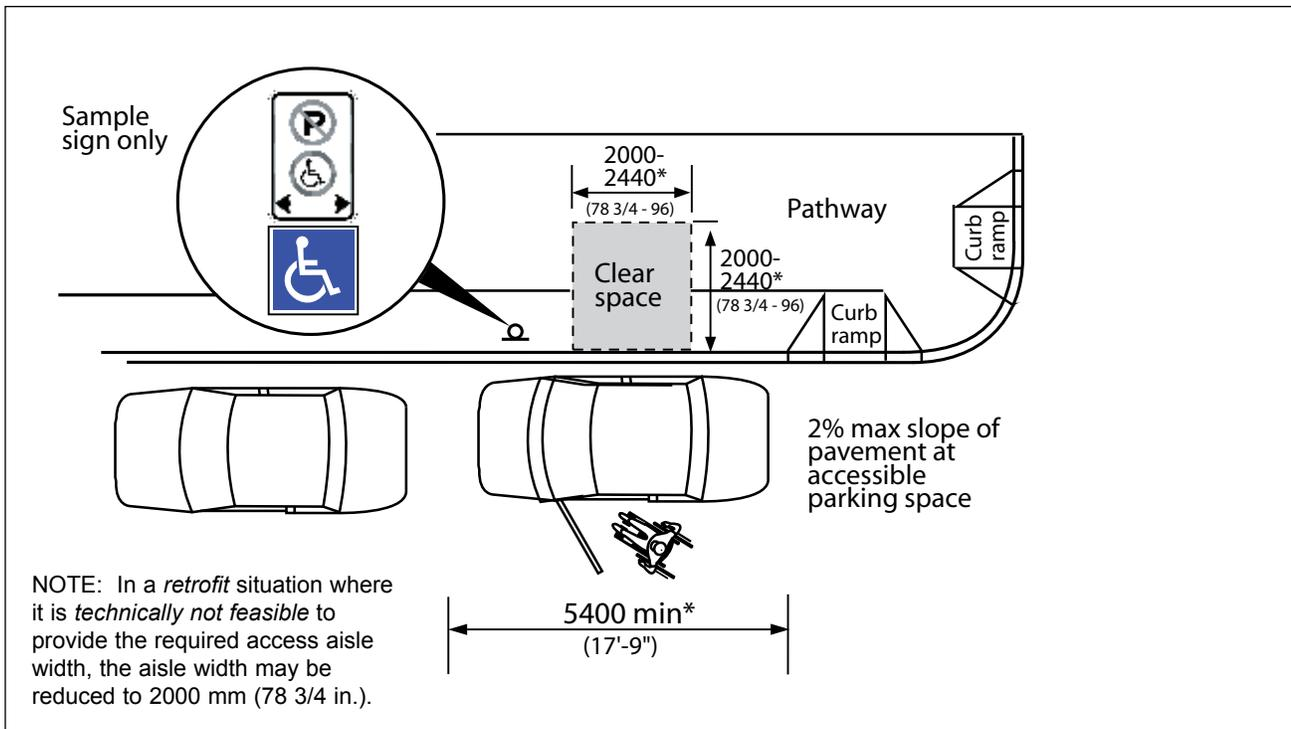

Figure 2.3.1.2 Parallel Parking Space

2.3 EXTERIOR CONTEXT SPECIFIC REQUIREMENTS

2.3.1 Parking (continued)

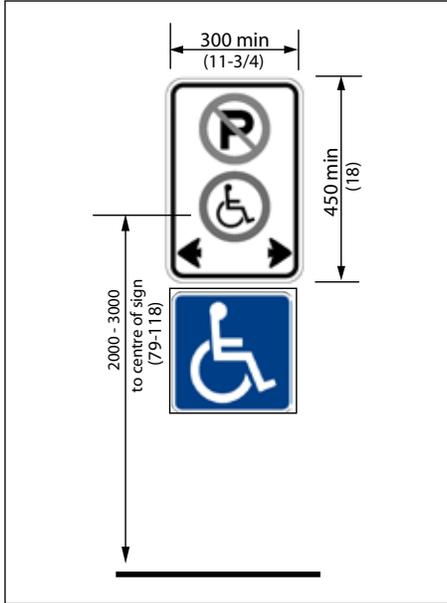

Figure 2.3.1.3 Parking Sign (Sample Sign Only)

Number of Automobile Parking Spaces	Number of Designated Parking Spaces
1-25	1
26-50	3
51-75	4
76-100	5
101-150	6
151-200	7
201-300	8
301-400	9
401-500	10
501-1000	2% of total
1001 and over	20 plus 1 for each 100 over 1000

Table 2.3.1.1 Accessible Parking Space Allocation

2.3 EXTERIOR CONTEXT SPECIFIC REQUIREMENTS

EXTERIOR STANDARDS

2.3.2 Passenger Loading Zones

RATIONALE

Passenger loading zones are important features for individuals who may have difficulty walking distances or those who use parallel transit systems. *Accessible* transit vehicles typically require *space* for the deployment of lifts or *ramps* and overhead clearances. Protection from the *elements* will be beneficial to all users and particularly those that may have difficulty with mobility.

It is beneficial to provide interior and exterior waiting areas adjacent to passenger loading zones, preferably with *clear* sight lines to approaching vehicles.

APPLICATION

Accessible passenger loading zones shall be identified with *signage* complying with 'Provincial Highway Traffic Act' loading zone signage.

Where passenger loading zones are provided, at least one shall comply with this section.

If the passenger loading zone is a designated Handi-Transit stop zone, it shall comply with all relevant municipal bylaws.

DESIGN REQUIREMENTS

Passenger loading zones shall

- be on an *accessible route* complying with Section 1.1.3 Accessible Routes, Paths and Corridors;
- provide an *access aisle* at least 2000 mm (78-3/4 in.) wide and 7000 mm (23 ft.) long, adjacent and parallel to the vehicle pull-up *space*;
- have a *curb ramp* complying with 2.1.5 where there are curbs between the *access aisle* and the vehicle pull-up *space*; and
- have a minimum vertical clearance of 3600 mm (11 ft. - 10 in.) at the loading zone and along the vehicle access route to such areas to and from the *site entrances*.

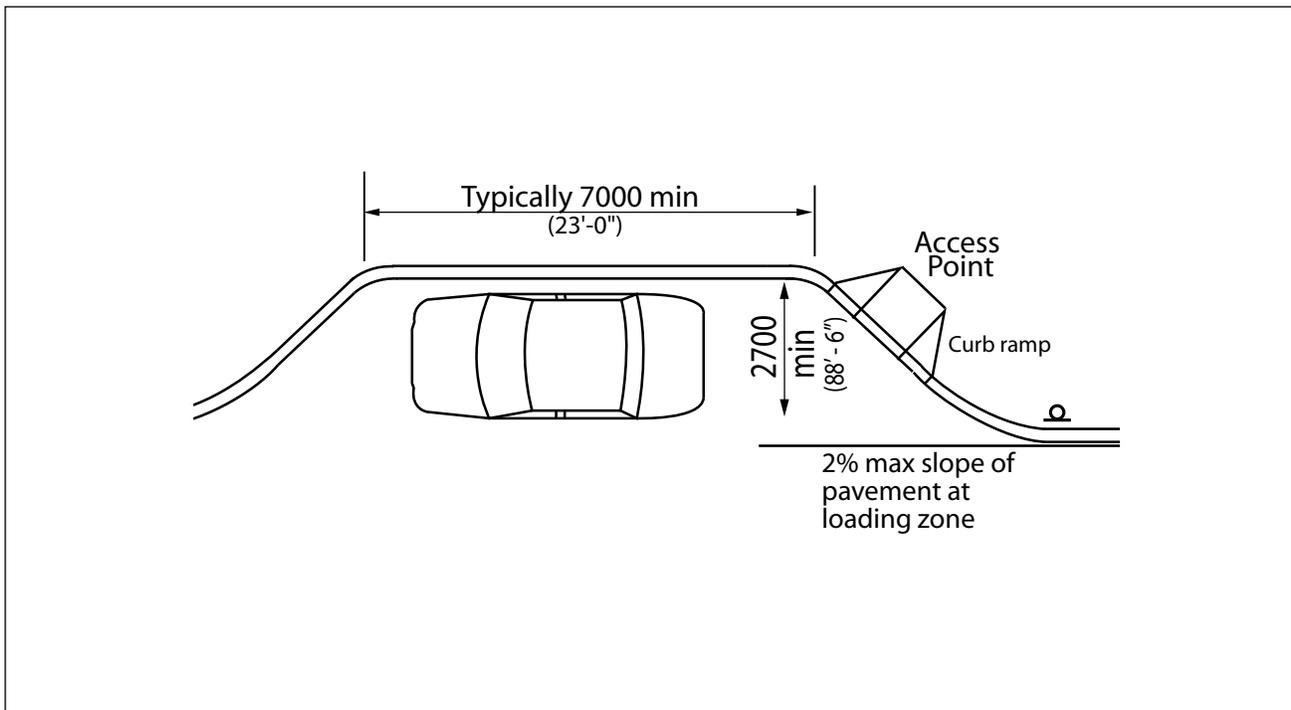

Figure 2.3.2.1 Off-Street Lay-by Passenger Loading Zone

2.3.2 Passenger Loading Zones (continued)

RELATED SECTIONS

- 1.1.1 Space and Reach Requirements
- 1.1.2 Protruding and Overhead Objects
- 1.1.3 Accessible Routes, Paths and Corridors
- 1.2.1 Texture, Finishes and Colour
- 1.2.4 Signage
- 1.2.6 Detectable Warning Surfaces
- 2.1.1 Exterior Ground Surfaces
- 2.1.2 Exterior Lighting
- 2.1.3 Streetscape
- 2.1.5 Curb Ramps and Truncated Dome Detectable Warning Surfaces

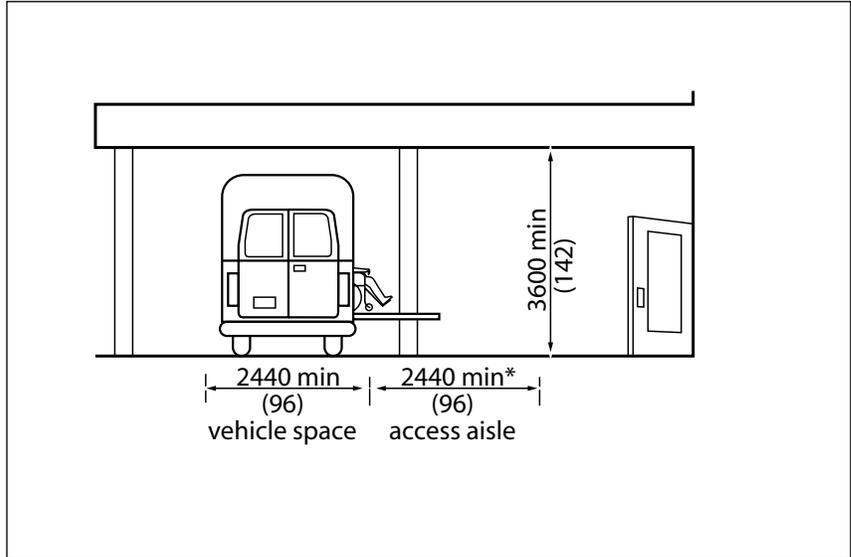

Figure 2.3.2.2 Height Clearances at Passenger Loading Zone

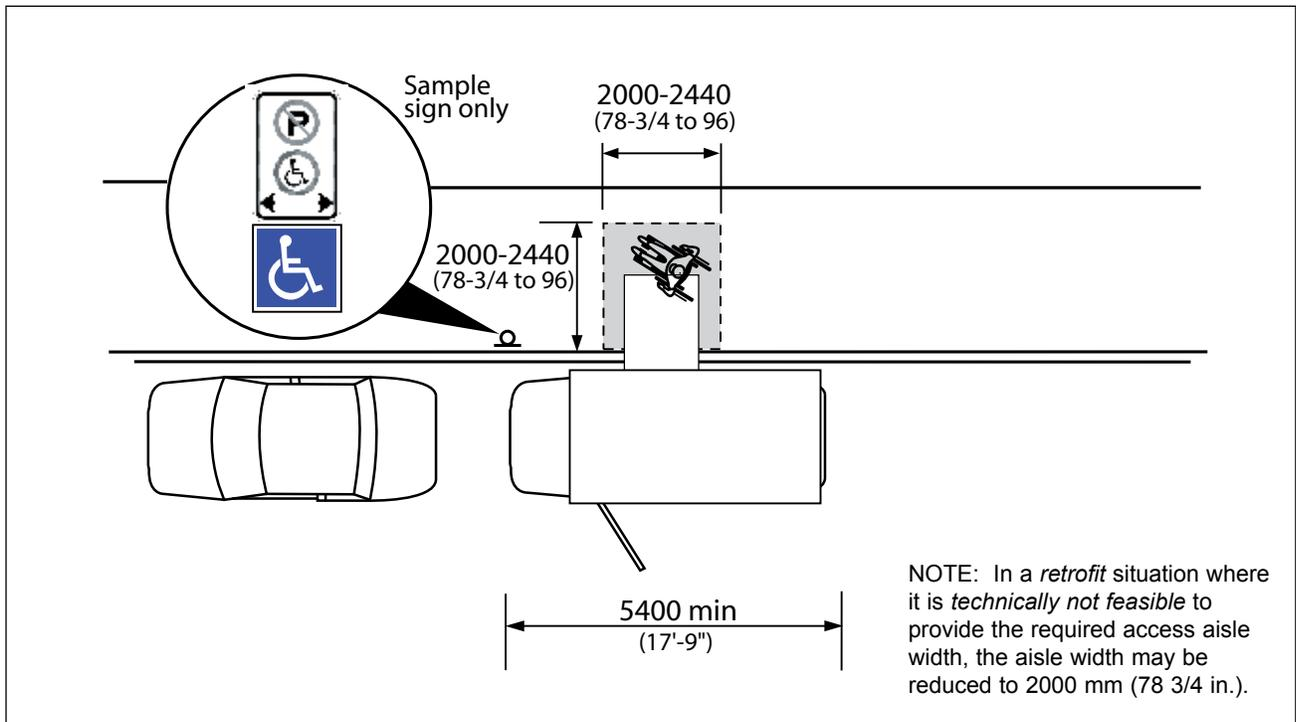

Figure 2.3.2.3 On-Street Passenger Loading Zone

2.3 EXTERIOR CONTEXT SPECIFIC REQUIREMENTS

EXTERIOR STANDARDS

2.3.3 Outdoor Recreational Facilities

RATIONALE

Opportunities for recreation, leisure and active sport participation should be available to all members of the community. Access should be provided to playing fields and other sports *facilities*, including access to the *site*, all activity areas, outdoor trails, docks, swimming areas, play *spaces*, lockers, change rooms and showers.

APPLICATION

In addition to the design requirements specified in Sections 1.0 General Design Standards, 2.0 Exterior Design Standards and 3.0 Interior Design Standards, the outdoor recreation *facilities* listed below shall comply with this section.

Where dressing *facilities* are provided for use by the general public, clients, customers, performers or staff, at least 50%, but never less than one, for each type of use in each cluster of dressing *facilities* shall be *accessible* and in compliance with Section 3.2.6 Specialty Change Rooms. It is preferable to have all dressing *facilities accessible*.

All waste receptacles, except those located in unpaved areas of *parks*, wilderness, beach or picnic areas, shall be *accessible* to persons using wheelchairs or other mobility devices.

DESIGN REQUIREMENTS

General

Parks accessibility shall encompass the development of *active transportation routes*, auxiliary services, planting and an overall environment which is *accessible* and provides a fulfilling recreational experience.

ACTIVE TRANSPORTATION ROUTES

The principal consideration when planning for, designing and siting new active transportation routes is the need of pedestrians. Because of the inherent conflict between bicycles and pedestrians, the primary aim of designing any recreational pathway is complete separation of conflicting uses.

This can be achieved by

- providing for bicyclists on the *street right-of-way*;
- providing a continuous physical barrier between bicyclists and pedestrians, such as railings or a level difference between the bicycle path and the footpath.

Where pedestrians, bicycle and vehicular paths of travel cross or converge, pedestrians tend to be most vulnerable. Therefore, giving priority consideration to pedestrian needs in these instances is extremely important.

Boardwalks

Where boardwalks are provided, they shall

- have a minimum width of 2440 mm (96 in.);
- incorporate surfaces constructed of firm, non-slip materials. Where wooden planks are used, they shall be laid perpendicular to the path of travel and have joints no greater than 6 mm (1/4 in.);
- incorporate a continuous upstand edge where the grade drop-off on any side of the boardwalk is greater than 200 mm (7-7/8 in.). The upstand edge shall be at least 100 mm (4 in.) high and of a contrasting colour to the surrounding terrain;
- have *handrails*, *guards* or other suitable barriers on both sides where the grade drop-off is greater than 76 mm (3 in.) and within 610 mm (24 in.) from any walking surface edge. Refer to Figure 1.1.3.1 in Section 1.1.3 Accessible Routes, Paths and Corridors;
- incorporate level access points to the boardwalk from *accessible* routes; and
- where benches, waste receptacles, drinking fountains, etc., are provided, they shall be located adjacent to the boardwalk on firm, level surfaces at the same elevation as the boardwalk. Refer to Section 2.1.3 Streetscape.

2.3 EXTERIOR CONTEXT SPECIFIC REQUIREMENTS

2.3.3 Outdoor Recreational Facilities (continued)

Footbridges, Steps and Ramps

Where significant changes in grade occur, trail routes (including bridges) shall ideally be sloped at no greater than 1:20 (5%), or have adjacent steps and *ramps*. If trail routes are sloped steeper than 1:20 (5%), alternate routes shall be provided.

Where steps, footbridges or *ramps* are used, the surfacing shall be of non-slip materials and include suitable *colour contrasting handrails* and/or *guards*. Refer to Sections 1.1.5 Ramps, 1.1.6 Stairs and 1.1.7 Handrails and Guards.

Pathways

All pathways shall be considered to be *accessible routes* and walkways and shall conform with Section 1.1.3 Accessible Routes, Paths and Corridors.

Waste receptacles, light standards, benches and other potential obstructions shall be located so as not to obstruct the *clear path of travel*. Refer to Section 2.1.3 Streetscape.

A different ground colour and/or texture shall be used to indicate the following

- risk areas, such as intersections, *ramps* or steps;
- functional changes, such as seating areas, viewpoints or outlooks. Refer to Section 1.2.1 Texture, Finishes and Colour; and

- vertical elements that are not *cane detectable*. Refer to Section 1.1.2 Protruding and Overhead Objects.

Bicycle Pathways

These pathways are physically separated from motor vehicle traffic and from sidewalks or pedestrian pathways, and are reserved for use by bicycles and other types of wheeled vehicles (in-line skates, scooters, wheelchairs, etc.).

Access points to bicycle pathways shall be designed to avoid mistaken use of facility by pedestrians.

Trails

When not paved, the use of hard-packed granular is accepted. For specific details contact the design branch of the City of Winnipeg Planning and Land Use Department.

Multi-Use Pathways

Only where there is insufficient space to accommodate separate pedestrian and bicycle pathways a *multi-use pathway* may be considered.

Where a *multi-use pathway* must be used, separation shall be achieved through the use of a central colour contrasted band to delineate direction of travel.

AMENITIES

Planting and Trees

Planting and trees along *accessible* path ways shall comply with Section 2.2.2 Plantings.

Rest Areas

Rest areas shall

- be provided on trails, pathways and walkways;
- be positioned adjacent to the trail, pathway or walkway;
- have *accessible* ground surfaces in compliance with Section 2.1.1 Exterior Ground Surfaces;
- use a contrasting ground finish material to identify functional change; and
- incorporate at least one bench, in compliance with Section 1.3.6 Benches.

Parks, Parkettes and Playgrounds

Entrance gates, paths and walkways throughout the *park* shall be *accessible* to persons using wheelchairs or scooters.

Picnic and play areas shall be provided in both sunny and shaded areas.

Outdoor Pools

Outdoor swimming pools shall comply with Section 1.4.1 Swimming Pools.

EXTERIOR STANDARDS

2.3.3 Outdoor Recreational Facilities (continued)

Picnic Tables

Accessible picnic tables shall comply with Section 2.2.3 Picnic Tables.

Where public parking is provided to serve picnic *facilities*, *accessible* picnic areas shall be within 30 meters (100 ft.) of the *accessible* parking spaces.

Docks

Where docks for fishing, boating, water-taxi or swimming are provided they shall

- be located on an *accessible route* in compliance with Section 1.1.3 Accessible Routes, Paths and Corridors;
- incorporate smooth and stable surfaces at transition points (such as from a walkway to a dock, or between adjacent dock units);
- incorporate clearly painted markings at transition points;
- where changes in elevation are necessary, incorporate *ramps* or *curb ramps* in compliance with Sections 1.1.5 Ramps and 3.1.4 Windows, Glazed Screens and Side-lights. *Ramps* with a slope no greater than 1:12 (8.3%) at low water are acceptable;
- be no higher than 600 mm (23-3/4 in.) above the water;
- incorporate a continuous upstand edge, at least 100 mm (4 in.) high and of a contrasting colour.
- Exception: Where boat loading openings are provided; incorporate a *guard* where

dock surfaces are greater than 450 mm (17-3/4 in.) above the surface of the water; and

- where steps are provided to access the water for swimming, incorporate *colour contrasting handrails* at the steps. Such *handrails* shall extend to a minimum of 600 mm (23-5/8 in.) above the dock surface and return down to the dock.

Drinking Fountains

Accessible drinking fountains shall comply with Section 1.3.1 Drinking Fountains.

Public Telephones

Accessible public telephones shall comply with Section 1.3.3 Public Telephones.

Illumination

Where provided, illumination levels shall

- be a minimum of 10 lux (1 ft-candle);
- be maintained at 5 lux (0.5 ft-candles) in areas of heavy trees and shrubbery; and
- be maintained at 5 lux (0.5 ft-candles) in all other areas of *park* at ground level.

Light sources used shall be indirect, non-glare, non-flickering type and provide even levels of light distribution. Refer to Section 2.1.2 Exterior Lighting.

Washrooms

Where washrooms are provided, they shall conform with Section 3.3.1 Toilet and Bathing Facilities.

Waterfront Areas

Where paths and/or lookout points are provided, they shall be *accessible* to all individuals.

Seating shall be provided along paths and at lookout points, in compliance with Section 1.3.6 Benches.

Where parking is provided, it shall be located as close as possible to key points of attraction. An *accessible route* shall be provided from the parking area to paths and/or lookout points (where provided).

Natural Areas

Accessible pathways, trails and footbridges shall be provided where environmental considerations will permit.

Paths and trails shall incorporate rest areas with appropriate seating.

Where special lookout locations or wildlife viewing areas are provided, they shall be identified with *clear signage*.

Trails shall feature a *tactile* map at the start of the trail and periodically along its length that shall

- have the critical trail features embossed; and

2.3.3 Outdoor Recreational Facilities (continued)

- important text in raised lettering and Grade 1 uncontracted Braille.

Playing Fields and Spectator Areas

Controlled access points shall be designed to accommodate persons using wheelchairs. (e.g., Where turnstiles are used, an

adjacent *accessible* gate shall be provided.)

Level seating areas shall be provided beside sports fields for spectators or participants with *disabilities*.

Where provided, public viewing areas shall comply with Section 1.3.4 Elevated Areas and Platforms.

Where provided, public washrooms shall comply with Section 3.3.1 Toilets and Bathing Facilities.

RELATED SECTIONS

All relevant parts of Sections 1.0 General Design Standards, 2.0 Exterior Design Standards and 3.0 Interior Design Standards.

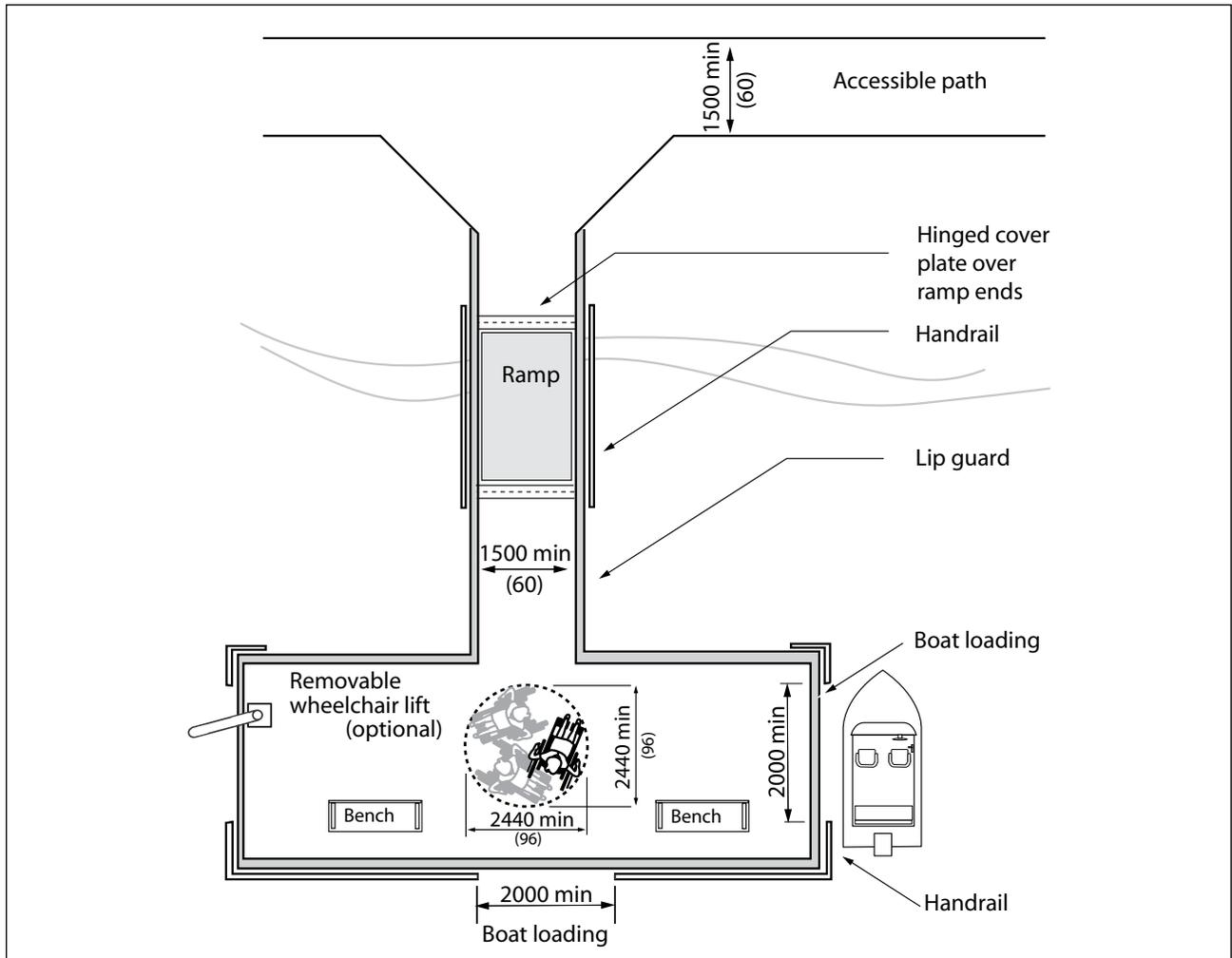

Figure 2.3.3.1 Accessible Dock

2.3 EXTERIOR CONTEXT SPECIFIC REQUIREMENTS

EXTERIOR STANDARDS

2.3.4 Transit Facilities

RATIONALE

Links to public transportation should be *accessible* to all members of a community.

Multiple modes of presenting scheduling information should be available (ie. electronic, audible, tactile, visual, etc.) wherever possible.

A large bus stop platform is required where *accessible* buses are used or where a large number of passengers are expected to congregate between bus arrivals. The large platform will accommodate the deploying (lowering) of a wheelchair *ramp* from a bus and to allow for wheelchair movement on and off the *ramp*, as well as alighting from the rear door.

If not properly placed and maintained, *street* furniture such as trees, newspaper boxes, waste and recycling receptacles can restrict access to bus stops.

APPLICATION

In addition to the design requirements specified in Sections 1.0 General Design Standards, 2.0 Exterior Design Standards and 3.0 Interior Design Standards, transportation *facilities* located within a *site* shall comply with this section.

DESIGN REQUIREMENTS

Bus Stop Platforms

Bus stop platforms shall

- be located on or immediately adjacent to an *accessible route* in compliance with Section 1.1.3 Accessible Routes, Paths and Corridors;
- be a minimum of 8500 mm (27 ft.) long and 2100 mm (84 in.) wide;
- be *clear* of all obstacles (including trees, newspaper boxes, waste and recycling receptacles); and
- maintain clearances as specified in Section 1.1.2 Protruding and Overhead Objects.

Where there is no *accessible* route from the sidewalk to the bus stop platform, two paved connections from the sidewalk to the platform shall be provided which

- are aligned with the edge of the platform;
- are at least 1500 mm (47 in.) wide;
- incorporate ground surfaces that comply with Section 2.1.1 Exterior Ground Surfaces;
- are *clear* of all obstacles (including trees, newspaper boxes, waste and recycling receptacles); and
- maintain clearance as specified in Section 1.1.2 Protruding and Overhead Objects.

Bus Passenger Shelters

Bus passenger shelters shall

- be located on an *accessible route* in compliance with Section 1.1.3 Accessible Routes,

Paths and Corridors;

- provide a *clear* view of oncoming traffic;
- be located on firm, level pads approximately at the same elevation as the sidewalk or walkway;
- incorporate access openings at least 950 mm (37-1/2 in.) wide;
- incorporate *clear space* in compliance with Section 1.1.1 Space and Reach Requirements to accommodate a person using a wheelchair or scooter;
- where glazed, incorporate a continuous horizontal safety strip decal which are a minimum 75 of mm (3 in.) wide, *colour contrasting*; and located 1400 - 1600 mm (55 - 63 in.) above ground level;
- where frameless glass is used adjacent to an access opening, incorporate a vertical *colour contrasting* safety stripe, applied to cap the end of the glass panel; and
- feature at least one seat with armrests and a seat height between 400 mm and 450 mm (15-3/4 in. and 17-3/4 in.).

RELATED SECTIONS

All relevant parts of Sections 1.0 General Design Standards, 2.0 Exterior Design Standards and 3.0 Interior Design Standards.

2.3 EXTERIOR CONTEXT SPECIFIC REQUIREMENTS

2.3.4 Transit Facilities (continued)

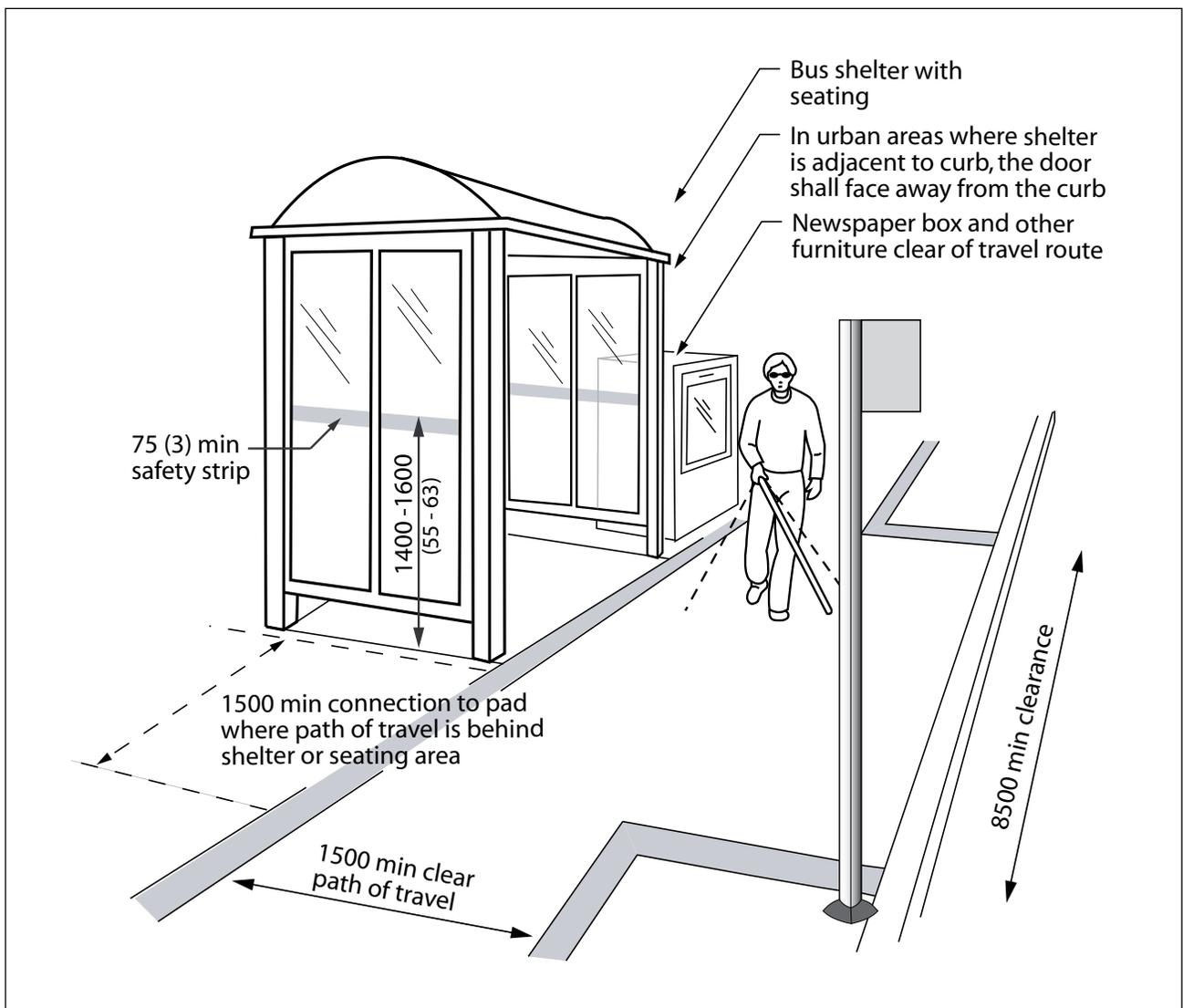

Figure 2.3.4.1 Bus Stop Platform with Shelter

2.3 EXTERIOR CONTEXT SPECIFIC REQUIREMENTS

EXTERIOR STANDARDS

2.3.5 Play Areas

RATIONALE

Children require access to play facilities to provide opportunities for the development of motor and cognitive skills, as well as opportunities for interaction and the development of socialization skills.

The integration of universally *accessible* play features within all play areas will benefit both care-givers and children with *disabilities*.

APPLICATION

Newly designed and newly constructed play areas for children ages 2 and over and altered portions of existing play areas shall comply with this section.

Ground level play components shall be provided in the numbers and types required in Table 2.3.5.2 and elsewhere in this section.

Where ground level play components are provided, at least one of each type provided shall be located on an *accessible* route in compliance with the design requirements of this section.

Where elevated play components are provided, ground level play components shall be provided in accordance with Table 2.3.5.2. Such ground level play components shall be located on an *accessible* route in compliance with the design requirements of this section.

Exception: Where at least 50% of the elevated play components are connected by a *ramp*, and if at least 3 of the elevated play components connected by the *ramp* are different types of play components.

Where elevated play components are provided

- at least 50% shall be located on an *accessible* route complying with the design requirements of this section; and
- where the elevated play components are connected by a *ramp*, the *ramp* shall comply with the design requirements of this section.

Exception: Transfer systems complying with the design requirements of this section are permitted to connect elevated play components, except where 20 or more elevated play components are provided, no more than 25% of the elevated play components shall be permitted to be connected by transfer systems. Refer to Table 2.3.5.1.

Access routes within the boundary of a play area shall connect

- ground level play components; and
- entry and exit points of the play components.

Where transfer systems are provided, an elevated play component shall be permitted to connect to another elevated play component, in lieu of an *acces-*

sible route.

The *clear* width of access routes within play areas shall comply with the design requirements of this section.

DESIGN REQUIREMENTS

Play areas shall comply with the latest edition of 'CAN/CSA-Z614 - Children's Playspaces and Equipment'.

Swings shall be placed away from other play areas and should be delineated by ground surfaces that feature colour and texture contrast.

Borders around play areas must incorporate an access point where accessible play components have been provided.

RELATED SECTIONS

All relevant parts of Sections 1.0 General Design Standards, 2.0 Exterior Design Standards and 3.0 Interior Design Standards.

2.3.5 Play Areas (continued)

Elevated Play Components		
Total Provided	Ramped Access	Ramp or Transfer System Access
Less than 20	not required	50% minimum
20 or more	25% minimum	25% minimum

Table 2.3.5.1 Access to Elevated Play Components

Number of Elevated Play Components Provided	Minimum Number of Ground Level Play Components Required to be on an Accessible Route	Minimum number of Different Types of Ground Level Play Components Required to be on an Accessible Route
1	Not Applicable	Not Applicable
2 to 4	1	1
5 to 7	2	2
8 to 10	3	3
11 to 13	4	3
14 to 16	5	3
17 to 19	6	3
20 to 22	7	4
23 to 25	8	4
More than 25	8 plus 1 for each additional three over 25, or part thereof	5

Table 2.3.5.2 The Number and Types of Ground Level Play Components Required to be on an *Accessible Route*

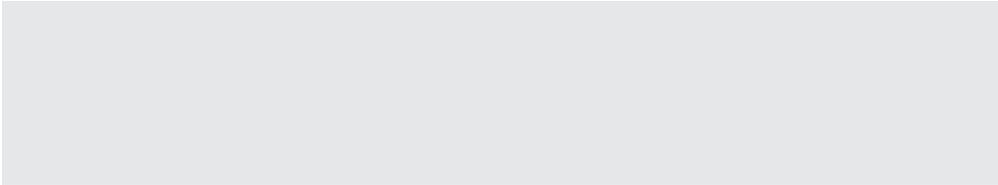

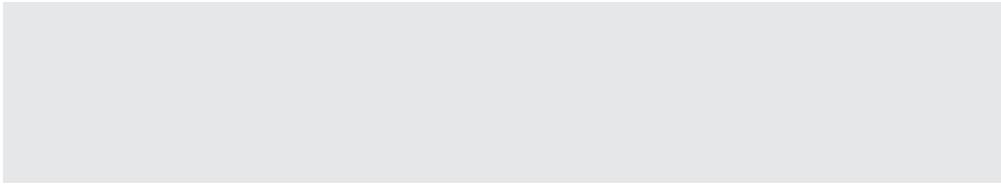

INTERIOR STANDARDS

INTERIOR STANDARDS

3.1.1 Interior Floor Surfaces

RATIONALE

The selection of flooring materials can be critical to the safe and easy movement of persons using all kinds of mobility aids, as well as persons with low vision.

Floor finishes, such as carpet, should be selected and installed so that persons using wheelchairs and walkers or other mobility aids can easily travel over them without using undue energy or tripping. Finishes that are slip resistant and not highly reflective also promote safe travel.

Glare from polished floor surfaces can be uncomfortable for all users and can be a particular obstacle for individuals with vision *impairments*.

Pronounced *colour contrast* between walls and floor finishes may be helpful for individuals with vision *impairments*, as are changes in colour/texture where a change in level or function occurs.

Caution is recommended in the selection of heavy or distinct patterns on walls or floors since these can add visual confusion to settings for persons with low vision or for persons with psychiatric disorders, if overused. Simple, repetitive and non-directional patterns with low contrast are preferred (e.g., for carpeting, floor tiles, wall papers, etc.) in order to produce the least amount of visual confusion.

Thick pile carpeting makes pushing a wheelchair very difficult. Small and uneven changes in floor level represent a further barrier to using a wheelchair but also present a tripping hazard to ambulatory persons.

APPLICATION

Floor surfaces along all routes generally used by staff and public and within all areas generally used by staff and public shall comply with this section.

DESIGN REQUIREMENTS

Floor surfaces shall be stable, firm, slip resistant and glare-free.

Floor surfaces shall not be heavily patterned.

Carpet shall be low profile or low loop construction, directly glued to the subfloor.

Where hard, monolithic materials are selected, they shall be non-slip and non-glare, complying with Section 1.2.1 Textures, Finishes and Colour.

Where floor tiles are used, joints should be no wider than 6 mm (1/4 in.) and should be flush.

Changes in level, except for elevators and other elevating devices, shall conform to Table 3.1.1.1.

Carpets or carpet tile shall

- be securely fixed;
- have a firm cushion, pad or backing, where used;
- have a level loop, textured loop, level cut pile, or level cut/uncut pile texture with a maximum pad and pile height of 13 mm (1/2 in.); and
- have exposed edges fastened to floor surfaces with trim conforming to Table 3.1.1.1.

RELATED SECTIONS

- 1.1.3 Accessible Routes, Paths and Corridors
- 1.1.5 Ramps
- 1.1.6 Stairs
- 1.2.6 Detectable Warning Surfaces
- 1.2.1 Texture, Finishes and Colour

3.1.1 Interior Floor Surfaces (continued)

Vertical Rise	Edge Treatment
0 to 6 mm (0 - 1/4")	May be vertical
Over 6 mm (over 1/4")	Treat as a sloped floor or ramp

Table 3.1.1.1 Changes in Floor Level

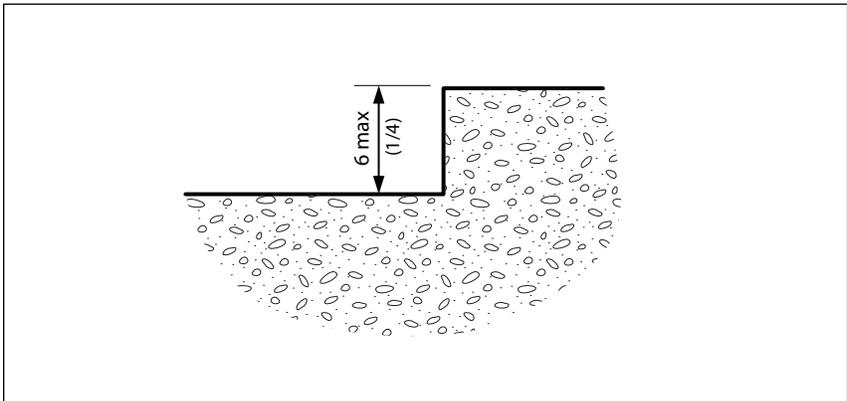

Figure 3.1.1.1 Changes in Level

INTERIOR STANDARDS

3.1.2 Entrances

RATIONALE

Design decisions concerning *entrances* will have an immediate impact on the independence and dignity of everyone entering a *facility*. *Entrances* that address the full range of individuals using the *facility* promote a spirit of inclusion that separate accessible *entrances* do not.

Features such as canopies are recommended to minimize the impact of weather conditions and also make an *entrance* more obvious to someone with a cognitive *impairment* or someone unfamiliar with the *facility*.

APPLICATION

All *entrances* used by staff or the public shall be *accessible* and comply with this section. In *retrofit* situations where it is *technically not feasible* to make all staff and public *entrances* accessible, at least 50% of all staff *entrances* and 50% of all public *entrances* shall be accessible and comply with this section.

In *retrofit* situations where it is *technically not feasible* to make all staff and public *entrances* accessible, the primary *entrances* used by staff and the public shall be *accessible* and comply with this section.

Accessible public *entrances* must be provided in a number at least equivalent to the minimum number of exits required by the *MBC*.

An *accessible* public *entrance* must be provided to each tenancy in a *facility*.

In police stations public *entrances* that are secured shall be *accessible* as required in Section 3.6.5 Emergency Services.

If direct access is provided for pedestrians from an enclosed parking garage to the *facility*, at least one direct *entrance* from the parking garage to the *facility* must be *accessible*.

If access is provided for pedestrians from a pedestrian tunnel or elevated walkway, one *entrance* to the *facility* from each tunnel or walkway must be *accessible*.

If the only *entrance* to a *facility* or tenancy is a *service entrance*, that *entrance* shall be *accessible*.

Entrances which are not *accessible* shall have directional *signage* complying with Section 1.2.4 Signage which indicates the nearest *accessible entrance*.

Accessible entrances shall be identified with *signage* complying with applicable provisions of Section 1.2.4 Signage.

RELATED SECTIONS

- 1.1.1 Space and Reach Requirements
- 1.1.4 Gates, Turnstiles and Openings
- 1.2.4 Signage
- 1.2.5 Information Systems
- 2.1.3 Streetscape

- 3.1.3 Doors
- 3.1.4 Windows, Glazed Screens and Sidelights
- 3.5.2 Card Access, Safety and Security Systems
- 3.5.3 Interior Lighting

3.1.2 Entrances (continued)

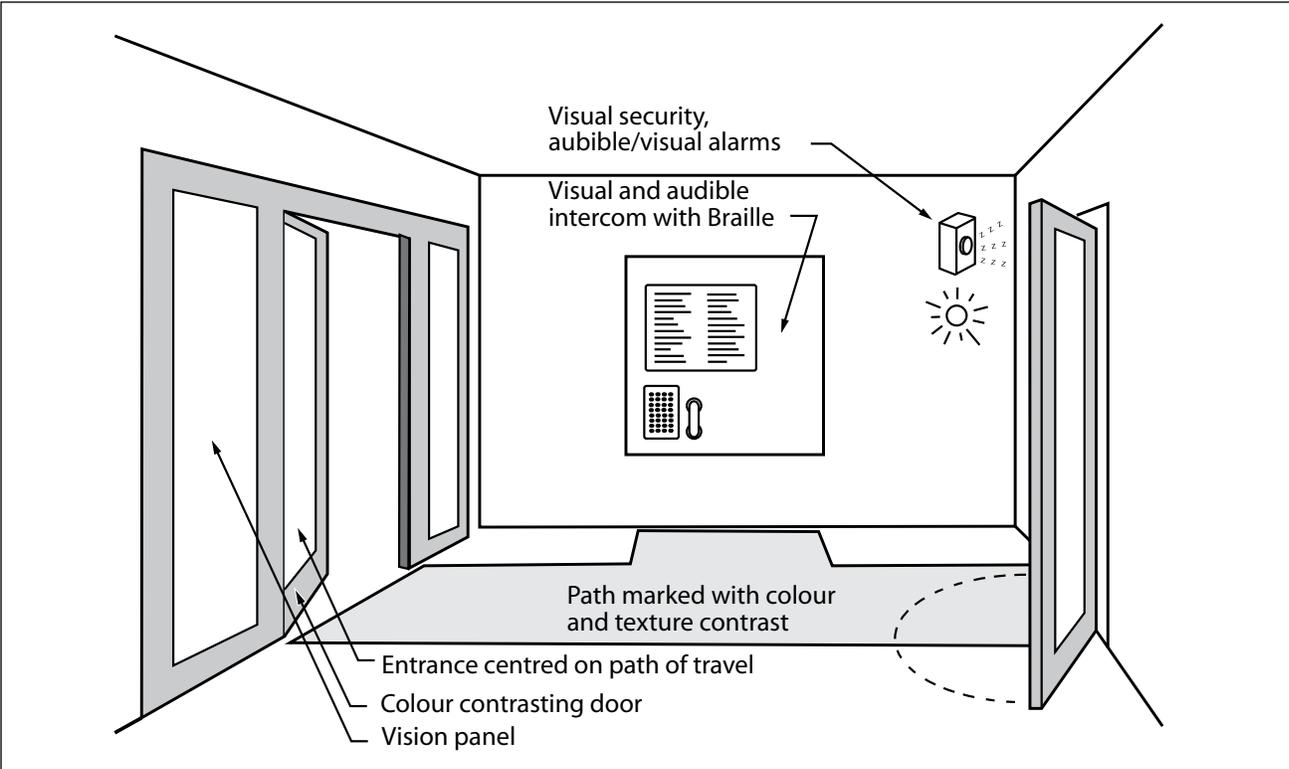

Figure 3.1.2.1 Typical Entrance Foyer

INTERIOR STANDARDS

3.1.3 Doors

RATIONALE

Sufficiently wide doorways will be advantageous to individuals using wheelchairs, pushing strollers, or making a delivery. A raised threshold at the base of the door could impede any one of these same individuals. This same group, with the addition of children, seniors or even someone carrying packages, would have difficulty opening a heavy door and would benefit from some form of *automatic door opener*. *Entrances* without doors are preferred.

Independent use of doors is desirable. Reliance on assistance from others to open doors is not an *accessible* or dignified solution. Automatic hands-free doors provide the most independence.

Where there is ambiguity of which direction the door swings ensure adequate information is provided regarding direction.

Careful thought to the direction of the door swing can enhance the usability and limit the hazard to other pedestrians. Sliding doors can be easier for some individuals to operate, and can also require less wheelchair maneuvering *space*. Doors that require two hands to operate are not considered to be accessible. Revolving doors are not accessible for persons using wheelchairs and strollers. The coordination required to use such doors may be difficult for children or someone with a cognitive *impairment*.

Glazed doors can present a hazard to all individuals and especially those with vision *impairments*. The inclusion of *colour contrast* strips across the glass, mounted at eye level, as well as *colour contrasting* door frames and door hardware, will increase the safety and visibility of a glazed door for a person with a vision *impairment*. Etching on glass may not provide adequate contrast. Frameless glass doors are not recommended.

APPLICATION

All doors used by staff or the public shall comply with this section. In a *retrofit* situation where it is *technically not feasible* to make all doors *accessible*, at least one door at each *accessible space* shall comply with this section. Exception: Doors not requiring full user passage, such as shallow closets, may have the *clear* opening reduced to 510 mm (20 in.) minimum.

Each door that is an *element* of an *accessible route* shall comply with this section.

Each door required by Section 3.1.8 Emergency Exits, Fire Evacuation and Areas of Rescue Assistance shall comply with this section.

Where a door system incorporates multiple door leaves at a single location, at least one of the door leaves shall comply with this section.

Power operators shall be provided at the following door locations:

- *entrances* required by Section 3.1.2 Entrances;
- washrooms that include an *accessible* toilet stall, where there is no individual wash-room on the same floor. Exception: Where there is at least one other male and female washroom with accessible toilet stalls on the same floor, that are equipped with a power door operator;
- *accessible* individual wash-rooms;
- *accessible* change rooms;
- intermediate doorways across primary circulation routes within a *facility*. Exception: Doors that are held-open using electromagnetic hold-open devices; and
- *entrances* into primary functional areas within a *facility*, as designated by the *City of Winnipeg*. Exception: Doors that are held-open using electromagnetic hold-open devices.

Mats and mat sinkages at doors shall comply with this section.

Revolving doors or turnstiles shall not be the only means of passage at an *accessible entrance* or along an *accessible route*. An *accessible* gate or door shall be provided adjacent to the turnstile or revolving door and shall be designated to facilitate the same use pattern.

3.1.3 Doors (continued)

DESIGN REQUIREMENTS

Door hardware on all doors throughout a *facility* (not only those deemed *accessible*), shall comply with the door hardware requirements of this section.

Accessible doors shall be on an *accessible route* that complies with Section 1.1.3 Accessible Routes, Paths and Corridors.

The minimum *clear* opening at doorways in *accessible* door systems shall be 915 mm (36 in.). In *retrofit* situations where it is *technically not feasible* to provide

this clearance, the minimum *clear* opening at doorways shall be required to meet *MBC* minimums.

Note: In order to achieve 915 mm (36") minimum clear opening width, the actual door must be 1000 mm (39") minimum.

Unless equipped with a power door operator, doors shall have level wheelchair maneuvering *space* on both sides of the door, and *clear space* beside the latch, as described in Table 4.1.6.

Exception: The *clear space* is not required on the inactive side of a

door, where access is provided from one side only - such as to a closet.

The required *clear space* beside the latch is to be unobstructed for the full height of the door.

The minimum *space* between two hinged or pivoted doors in series shall be 1525 mm (60 in.), plus the width of any door swinging into the *space*.

Thresholds shall be not more than 6 mm (1/4 in.) high.

Door hardware (operating devices

Context	Floor Space Required (in mm)		
	Depth	Width	Space beside latch
Side-hinged door - Front approach (Figure 3.1.3.3)			
Pull side	1525 (60 in.)	1600 (63 in.) (*1525 (60 in.))	600 (23-5/8 in.)
Push side	1370 (54 in.)	1250 (49-1/4 in.) (*1220 (48 in.))	300 (11-3/4 in.)
Side-hinged door - Latch-side approach (Figure 3.1.3.1)			
Pull side	1370 (54 in.) (*1220 (48 in.))	1600 (63 in.) (*1525 (60 in.))	600 (23-5/8 in.)
Push side	1370 (54 in.) (*1100 (43-1/4 in.))	1525 (60 in.)	600 (23-5/8 in.)
Side-hinged door - Hinge-side approach (Figure 3.1.3.2)			
Pull side	2440 (96 in.) (*1525 (60 in.))	2440 (96 in.) (*1525 (60 in.))	600 (23-5/8 in.)
Push side	1370 (54 in.) (*1100 (43-1/4 in.))	1830 (72 in.)	450 (17-3/4 in.)
Sliding door (Figure 3.1.3.8)			
Front approach	1370 (54 in.)	1100 (43-1/4 in.) (*920 (36 in.))	50 (2 in.)
Side approach	1370 (54 in.) (*1100 (43-1/4 in.))	1550 (61 in.) (*1370 (54 in.))	540 (21-1/2 in.)

Table 3.1.3.1 Maneuvering *Space* at Doors

In *retrofit* situations where it is *technically not feasible* to provide the required clearances at doors, the clearances may be reduced as shown by the asterix (*).

INTERIOR STANDARDS

3.1.3 Doors (continued)

such as handles, pulls, latches, and locks) shall

- not require fine finger control, tight grasping, pinching, or twisting of the wrist to operate; and
- be mounted with its centre located 850 mm - 950 mm (33-1/2 in. - 37-3/8 in.) from the floor.

Operating hardware on sliding doors shall be exposed and usable from both sides when sliding doors are fully open.

The maximum door opening force for pushing or pulling open a door shall be

- 38 N (8.5 lb.) for exterior

- hinged doors;
- 22 N (4.6 lb.) for interior hinged doors; and
 - 22 N (4.6 lb.) for sliding or folding doors.

Door closers shall be adjusted to the least pressure possible, but never more than the opening forces noted above.

The sweep period of door closers shall be adjusted so that, from an open position of 90 degrees, the door will take not less than 3 seconds to move to a semi-closed position of approximately 12 degrees.

Power-assisted swinging doors shall

- take not less than 3 seconds to move from the closed to the fully open position; and
- require a force of not more than 66 N (13.8 lb.) to stop door movement.

Permanent mats and metal gratings at *entrances* and in vestibules shall be recessed flush with the floor, so as not to create a tripping hazard.

Occasional mats (e.g. runners used in bad weather) should be level with the floor surface and/or have a gently beveled edge, so as not to create a tripping hazard.

Where power door operators are provided, operator controls shall

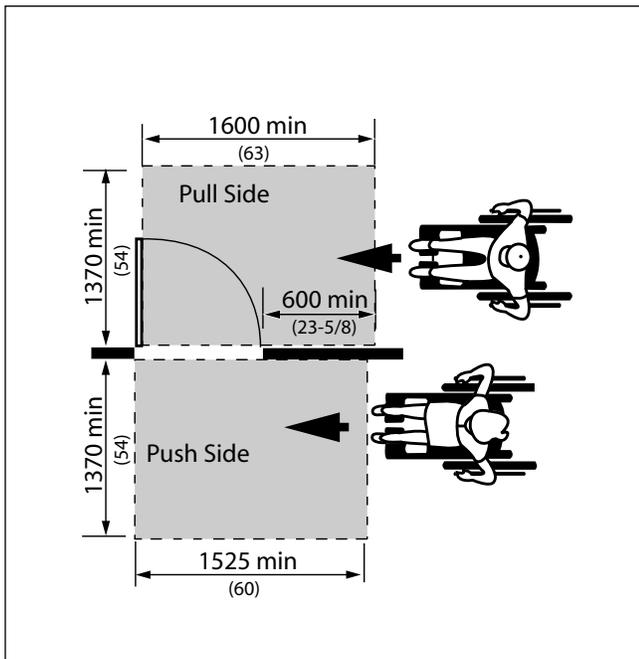

Figure 3.1.3.1 Latch Side Approach at Hinged Doors

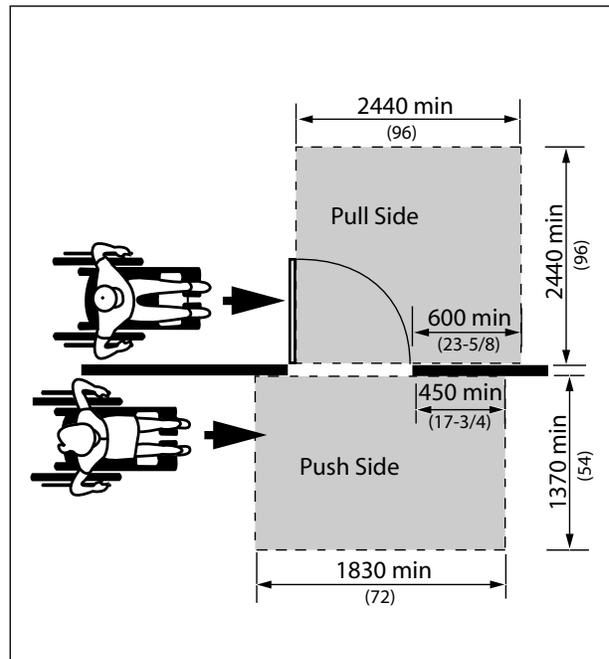

Figure 3.1.3.2 Hinge Side Approach at Hinged Doors

3.1.3 Doors (continued)

- be located to allow a person using a wheelchair or scooter to stop immediately adjacent to the control;
- be located no closer than 700 mm (27-1/2 in.) from an inside corner, for side-access;
- be located no closer than 400 mm (15-3/4 in.) from an inside corner, for front-access.
- if located on hinge side of door it controls, be located not less than 600 mm (23-5/8 in.) beyond the door swing, where the door opens towards the control;
- be operable at two heights, one with its centre located 850

- 950 mm (33-1/2 - 37-3/8 in.) from the floor; and the other with its centre located 225 mm (9 in.) from the floor. A single control bar that can be activated from either height is acceptable.
- incorporate controls that are clearly visible which are at least 150 mm (5-7/8 in.) in diameter;
- incorporate the International Symbol of Access for Persons with Disabilities;
- incorporate systems that will detect individuals using wheelchairs where pressure-sensitive mats, overhead

- beams or proximity scanners are used to detect traffic;
- incorporate safety *guards* that comply with Section 1.1.2 Protruding and Overhead Objects, projecting a minimum of 300 mm (11-3/4 in.) beyond both sides of the open door, where exterior doors swing open into a pedestrian area. See Figure 3.1.3.5 and 3.1.3.10.;
- provided a guard *colour contrasted* with the surrounding environment; the guard shall have a tactile floor finish length on all sides of the guard 300 mm (11 3/4 in.) along the floor surface.

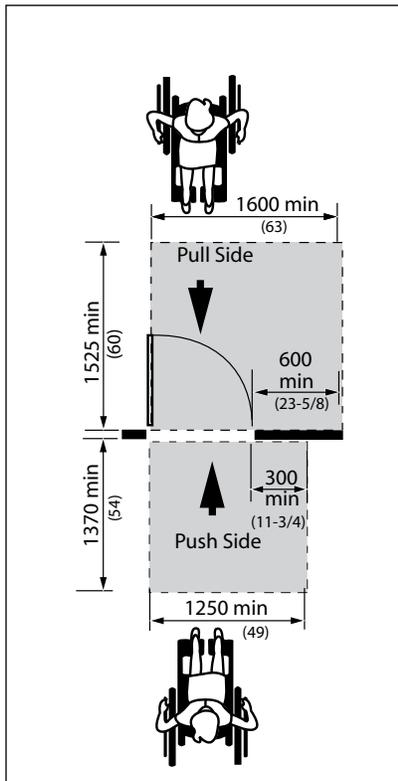

Figure 3.1.3.3 Front Approach at Hinged Doors

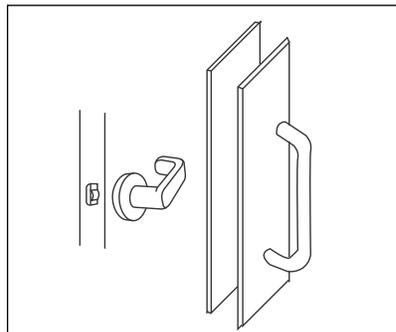

Figure 3.1.3.4 Examples of Accessible Hardware

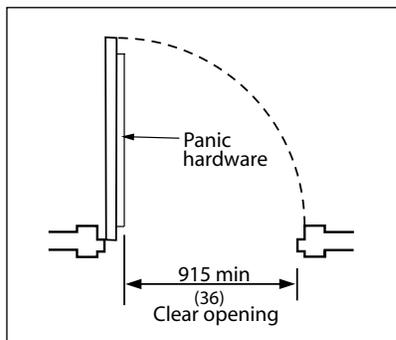

Figure 3.1.3.5 Minimum Clear Opening at Doors

Where doors are not equipped with a closing device, the edge of door shall be *colour contrasted* to the face of the door. See Figure 3.1.3.6.

On *accessible routes*, the bottom of doors shall incorporate a smooth, uninterrupted kick plate, at least 300 mm (11-3/4 in.) high.

Doors shall incorporate pronounced *colour contrast*, to differentiate them from the surrounding environment. Door handles and other operating mechanisms shall incorporate pronounced *colour contrast*, to differentiate them from the door itself.

Where a door incorporates glazing or is fully glazed, it shall comply with Section 3.1.4 Windows, Glazed Screens and Skylights.

3.1.3 Doors (continued)

Frameless glass doors shall comply with Section 3.1.4 Windows, Glazed Screens and Sidelights.

RELATED SECTIONS

- 1.1.1 Space and Reach Requirements
- 1.1.4 Gates, Turnstiles and Openings
- 1.2.4 Signage
- 1.2.5 Information Systems
- 3.1.4 Windows, Glazed Screens and Sidelights
- 3.5.1 Controls and Operating Mechanisms
- 3.5.2 Card Access, Safety and Security Systems

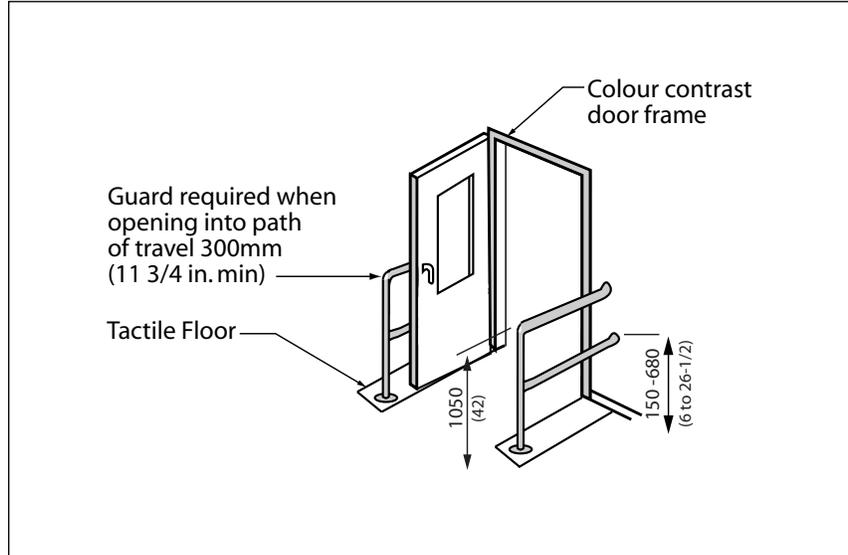

Figure 3.1.3.6 Colour Contrast at Doors and Protective Safety Guards

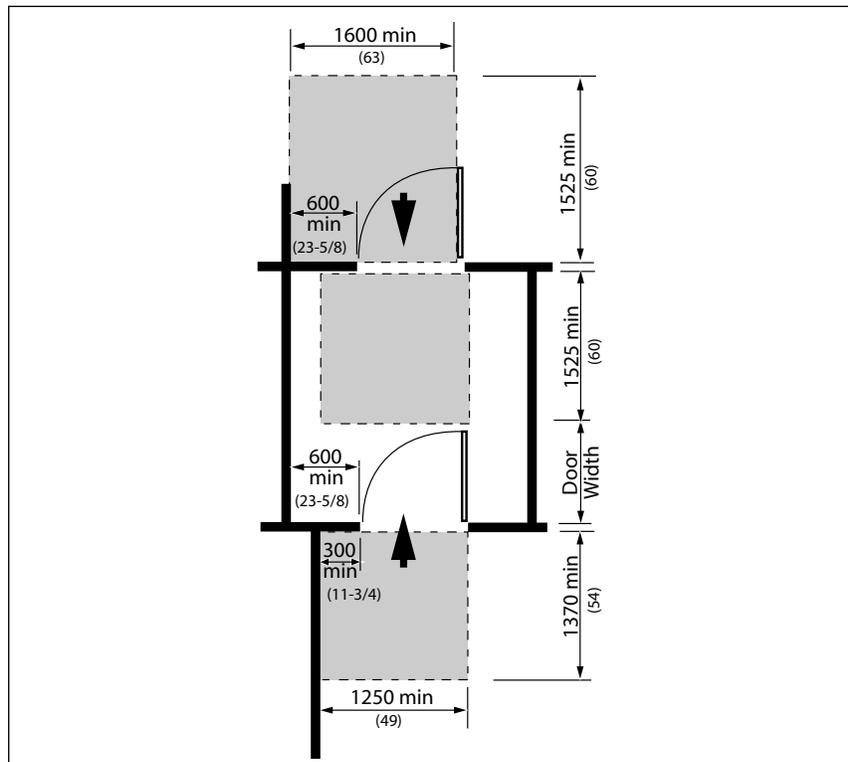

Figure 3.1.3.7 Maneuvering Space at Doors in Series

3.1.3 Doors (continued)

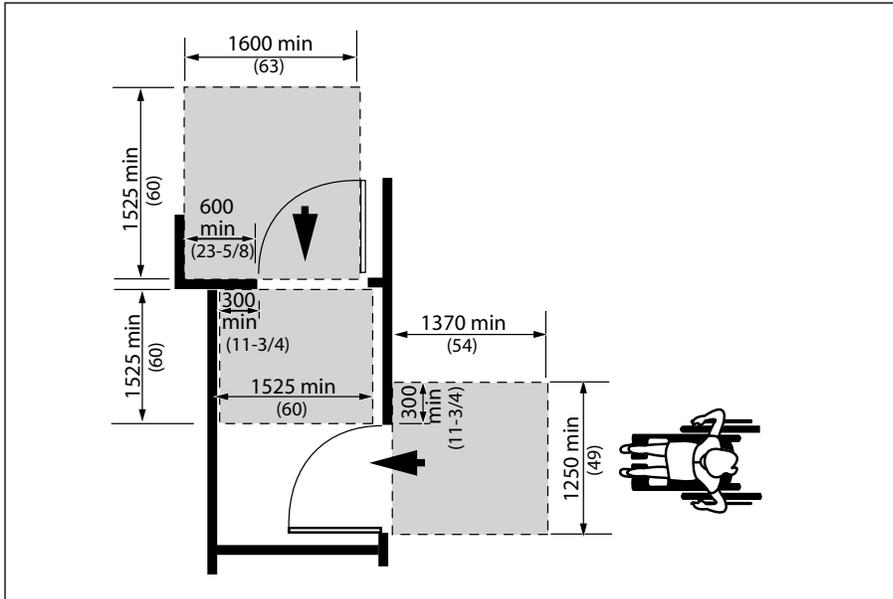

Figure 3.1.3.8 Maneuvering Space at Doors in Series

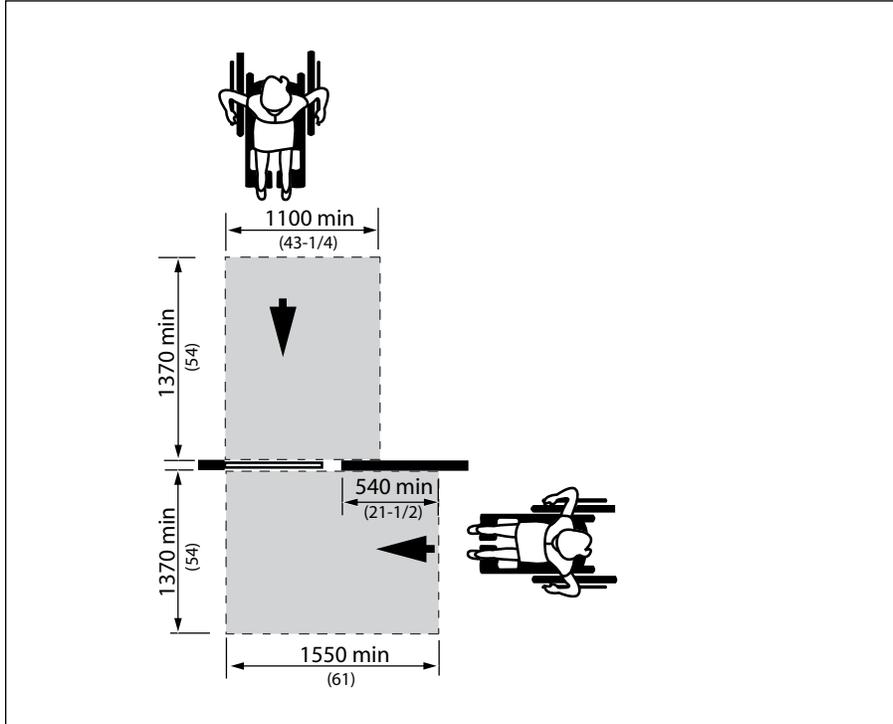

Figure 3.1.3.9 Front and Side Approach at Sliding Doors

3.1 INTERIOR ACCESS AND CIRCULATION

3.1.3 Doors (continued)

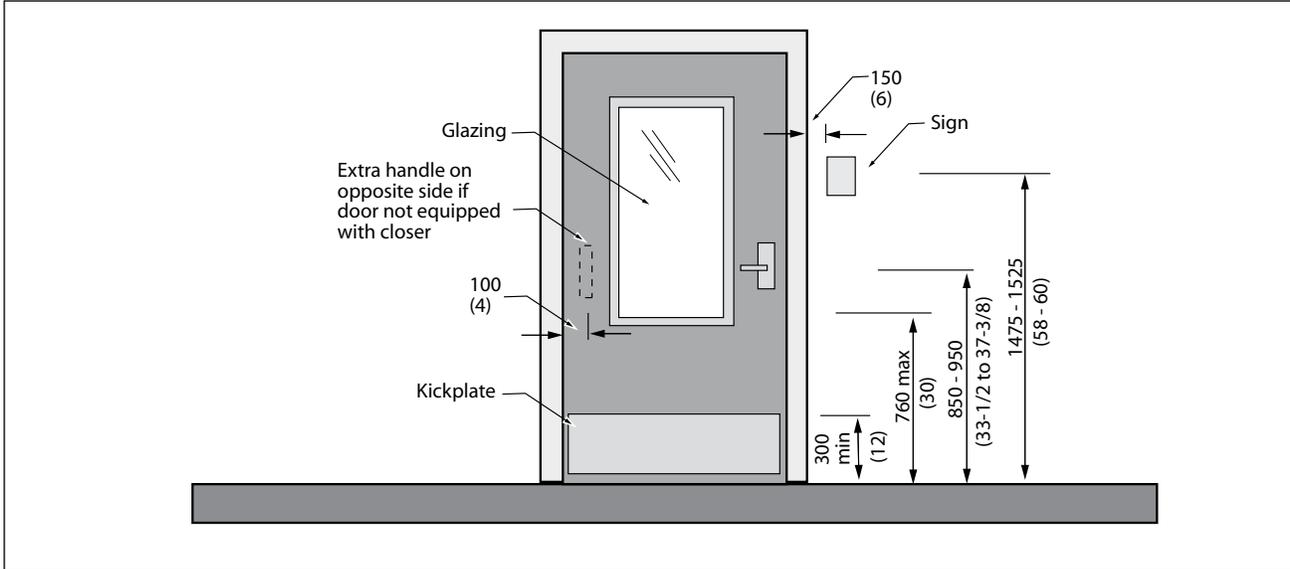

Figure 3.1.3.10 Door Features

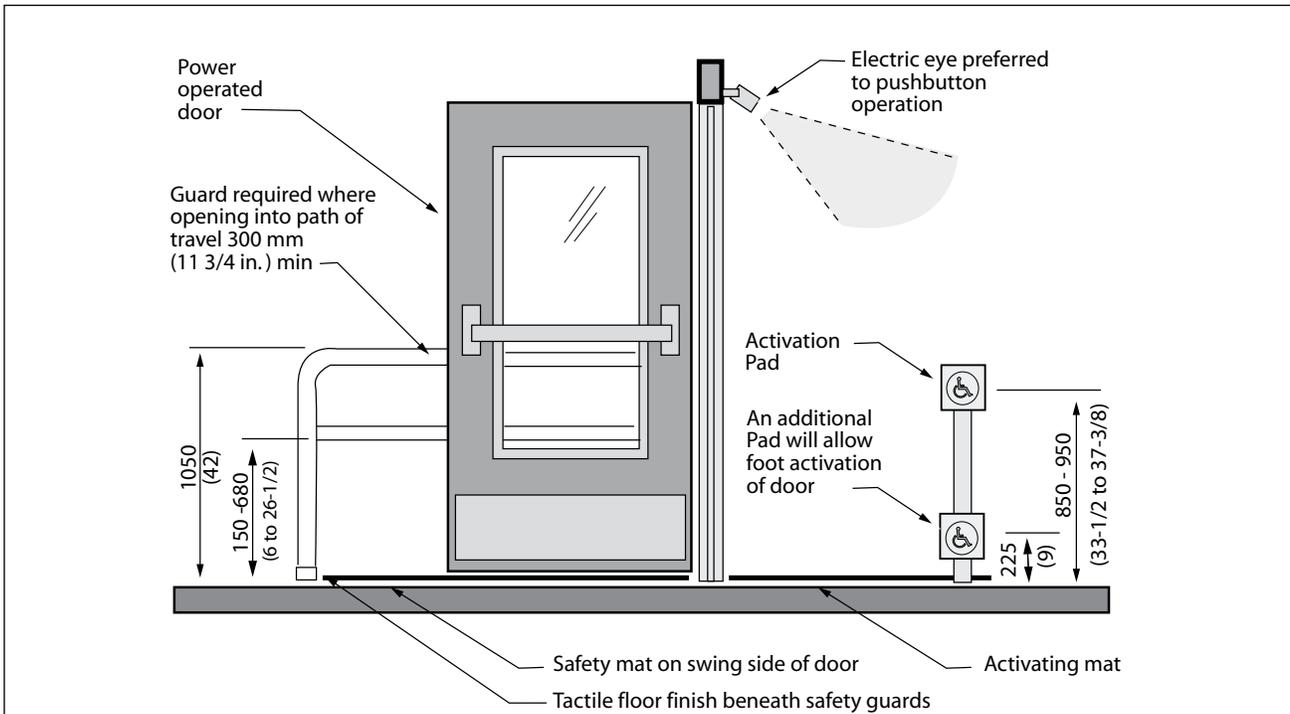

Figure 3.1.3.11 Power Door Features, Also Refer to Figure 3.1.3.7

3.1.4 Windows, Glazed Screens and Sidelights

RATIONALE

Broad expanses of glazing in screens, sidelights and doors can be difficult to detect. This may be a particular concern for individuals with vision *impairments*.

Persons who use wheelchairs or scooters experience the *facility* from a seated position thereby lowering their eye level and reach range. This necessitates the need for lower sill heights and easily reached operating mechanisms. Window controls and operating devices should also respect the limitations of hand strength or dexterity encountered with different types of *disabilities*, including arthritis.

APPLICATION

Where windows, glazed screens, fully-glazed sidelights, fully glazed doors, and glazed panels in doors are designed for viewing, they shall comply with this section.

DESIGN REQUIREMENTS

Fully-glazed sidelights at exterior *entrances* or vestibules, as well as fully-glazed screens, shall be clearly identified with a horizontal row of decals, or a continuous stripe, minimum 50 mm (2 in.) wide and of highly contrasting colour, mounted with its centre line between 1475 mm (58 in.) and 1525 mm (60 in.) from the floor or ground. Additionally, a second row of decals, or a continuous stripe, a minimum 50 mm (2 in.) wide and of highly contrasting

colour shall be provided, mounted with its centre line between 1170 mm (46 in.) and 1220 mm (48 in.) above the floor or ground.

Where decals are used, they shall be located at a maximum of 150 mm (5-7/8 in.) from centre to centre. The decals can either be 50 mm (2 in.) square or round, and/or of a special design (e.g., a logo) provided the solid portion of the decals provides high *colour contrast* and is easy to identify by individuals with vision *impairments*.

Where etched or patterned glass is used, decals or a stripe of highly *contrasting colour* shall still be provided.

Where frameless glass panels are used, exposed edges shall be identified with a vertical safety stripe applied to cap the end glass panel.

Where viewing windows or vision panels are provided,

- the sill height shall be no more than 760 mm (30 in.) from the floor; and
- where horizontal transoms are incorporated in windows, the transoms shall not be locate.

There may be additional guard requirements under the *MBC*.

In *facilities* with operable win-

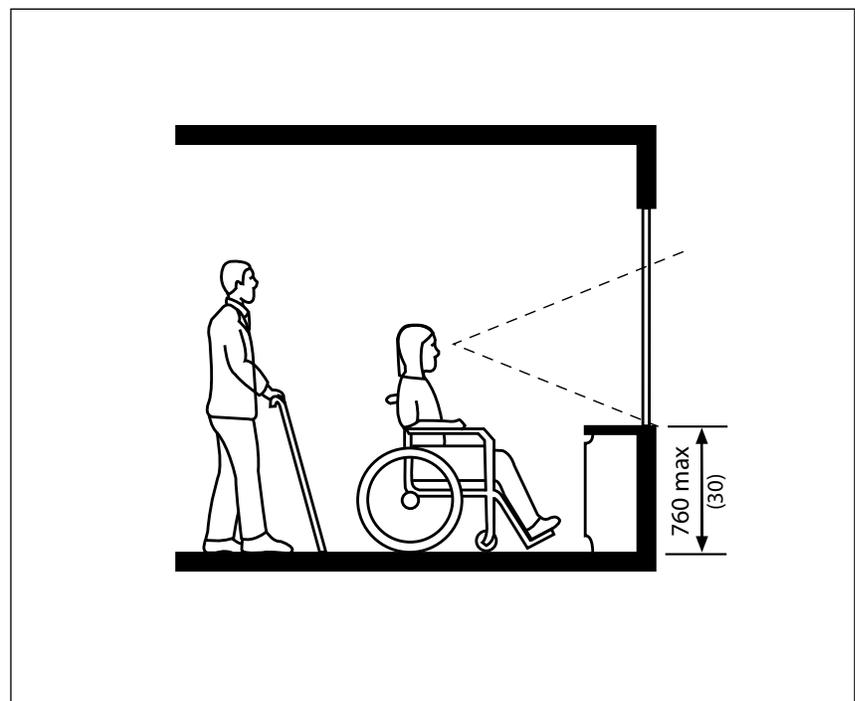

Figure 3.1.4.1 Window Sill Height

3.1.4 Windows, Glazed Screens and Sidelights (continued)

dows, window opening hardware shall

- be mounted between 400 mm (15-3/4 in.) and 1200 mm (47 in.) from the floor;
- be operable using one hand; and
- not require fine finger control, tight grasping, pinching, or twisting of the wrist to operate.

RELATED SECTIONS

- 1.1.1 Space and Reach Requirements
- 3.5.1 Controls and Operating Mechanisms

3.1.5 Elevators

RATIONALE

The buttons used on elevators need to address a range of functional issues as discussed in Sections 1.2.1 Texture, Finishes and Colour and 3.5.1 Controls and Operating Mechanisms. More specific to elevators is the need to provide audible cues for individuals with vision *impairments* to identify different floor levels and the direction of travel. These are of benefit to anyone who uses the elevator. Adequate door-closing delays provide individuals using mobility devices additional time to reach, enter or exit the elevator car.

APPLICATION

One passenger elevator complying with this section shall serve each level, including *mezzanines*, in all multi-storey *facilities*, unless exempted below. If more than one elevator is provided, each passenger elevator shall comply with this section.

Freight elevators shall not be required to meet the requirements of this section, unless the only elevators provided are used as combination passenger and freight elevators for use by the public and employees.

Elevator access is not required

- in elevator pits, elevator penthouses, mechanical rooms, piping or equipment catwalks;
- when *accessible ramps*

complying with Section 1.1.5 Ramps are used in lieu of an elevator; and

- when platform and wheelchair lifts complying with Section 3.1.6 Platform Lifts are used, applicable Provincial Codes are used in lieu of an elevator only under the following conditions:
 - to provide an *accessible route* to a performing area in an assembly occupancy;
 - to comply with wheelchair viewing position line-of-sight and dispersion requirements of Section 1.3.4 Elevated Areas and Platforms;
 - to provide access to incidental occupied spaces and rooms that are not open to the general public and which house no more than five persons, including, but not limited to, equipment control rooms and projection booths; and
 - to provide access to raised judges' benches, clerks' stations, speakers' platforms, jury boxes and witness stands or to depressed areas, such as the well of a court.

DESIGN REQUIREMENTS

Accessible elevators shall be on an *accessible route* complying with Section 1.1.3 Accessible Routes, Paths and Corridors.

Accessible elevators shall be identified with *signage* complying with applicable provisions of Section 1.2.4 Signage.

Elevators shall be automatic and be provided with a two way automatic levelling device to maintain the floor level to ± 13 mm (1/2 in.).

Accessible elevators shall have power operated horizontal sliding car and landing doors opened and closed by automatic means.

The *clear* width for elevator doors shall be at least 950 mm (37-1/2 in.). In a *retrofit* situation where it is *technically not feasible* to provide a *clear* elevator door width of 950 mm (37-1/2 in.), the *clear* elevator door width may be reduced to 900 mm (35 in.).

Doors shall be provided with a door re-opening device that will function to stop and reopen a car door and an adjacent hoist way door to at least 950 mm (37-1/2 in.), in case the car door is obstructed while closing. This re-opening device shall also be capable of sensing an object or person in the path of a closing door at a nominal 125 ± 25 mm (5 ± 1 in.) and 735 ± 25 mm (29 ± 1 in.) above the floor without requiring contact for activation.

Elevator doors should remain fully open for at least 8 seconds. This time may be reduced by operation of the door-close button.

The minimum distance between

INTERIOR STANDARDS

3.1.5 Elevators (continued)

the walls or between wall and door, excluding return panels, shall not be less than 1725 x 1525 mm (68 in. x 60 in.). In *facilities with high public use*, such as arenas, libraries or entertainment complexes, the distance between walls or between wall and door shall be 2030 x 1525 mm (80 in. x 60 in.).

Car controls shall be readily *accessible* from a wheelchair upon entering an elevator.

Floor register buttons in elevator cabs shall

- be a minimum 19 mm (3/4 in.) in size and may be raised, flush or recessed. The depth of flush or recessed buttons when they are being operated shall not exceed 10 mm (3/8 in.); and
- be provided with visual and momentary audible indicators to show when each call is registered. The visual indicators shall be extinguished when each call is answered.

All car control buttons shall be designated by Grade 2 Braille characters and by raised standard alphabet characters for letters, Arabic characters for numbers, and standard symbols. Markings shall be a minimum of 16 mm (5/8 in.) high and raised a minimum of 0.75 mm (1/32 in.), placed immediately to the left of the buttons to which they apply. Exception: Where the call buttons are mechanical, the raised

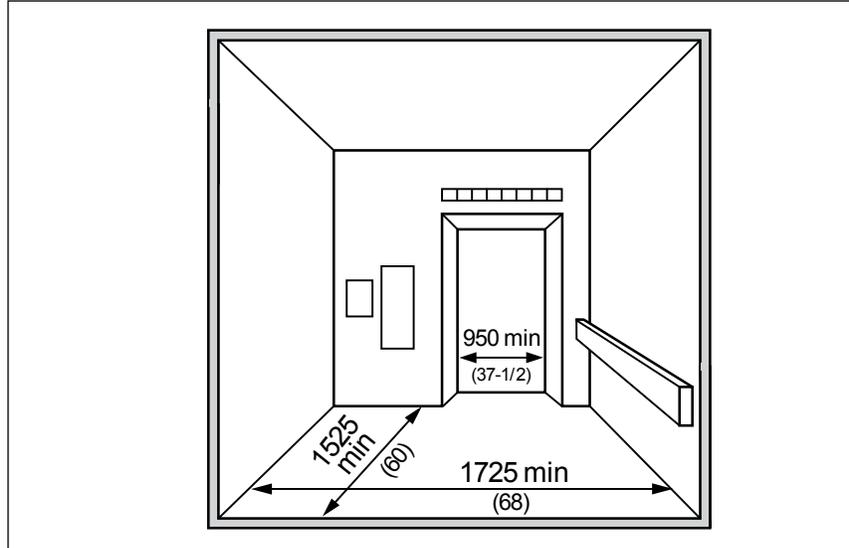

Figure 3.1.5.1 Elevator Cab

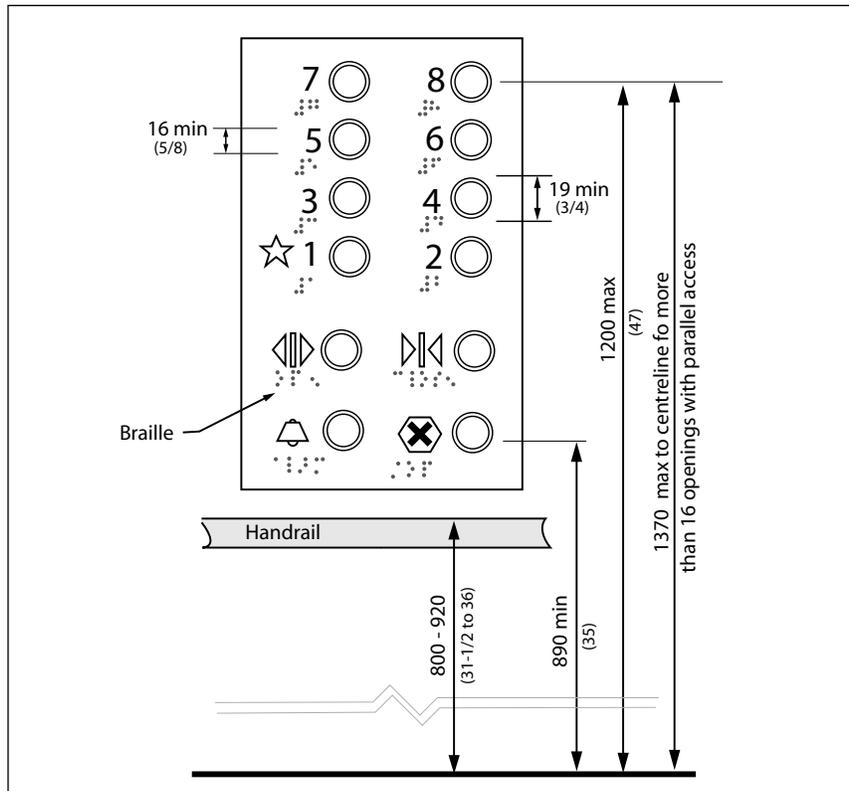

Figure 3.1.5.2 Control Panel

3.1.5 Elevators (continued)

markings may be on the buttons.

Emergency car controls and door-operating buttons shall be grouped together at the bottom of the control panel. The centre line of the alarm button and the emergency stop switch shall be not less than 890 mm (35 in.) from the floor. The centre line of the highest floor button shall be no higher than 1200 mm (47 in.) from the floor. Other controls may be located where it is convenient.

An indicator shall be provided in the car to show the position of the car in the hoist way, by illuminating the indicator corresponding to the landing at which the car is stopped or passing. Indication characters shall be on a contrasting colour background and a minimum of 16 mm (5/8 in.) high.

Floors of elevator cabs shall have a firm and slip-resistant surface that permits easy movement of wheelchairs.

Handrails shall be provided on all non-access walls at a height of 800 to 920 mm (31-1/2 to 36 in.) with a *space* of 40 to 45 mm (1-9/16 to 1-3/4 in.) between the rails and wall.

The illumination at the car controls and landing sill shall be not less than 100 lux (10 ft-candles) and shall be the same lighting level as the adjacent lobby space.

The centre line of hall call buttons shall be 920 ± 25 mm (36 ± 1 in.) above the floor. Buttons shall be

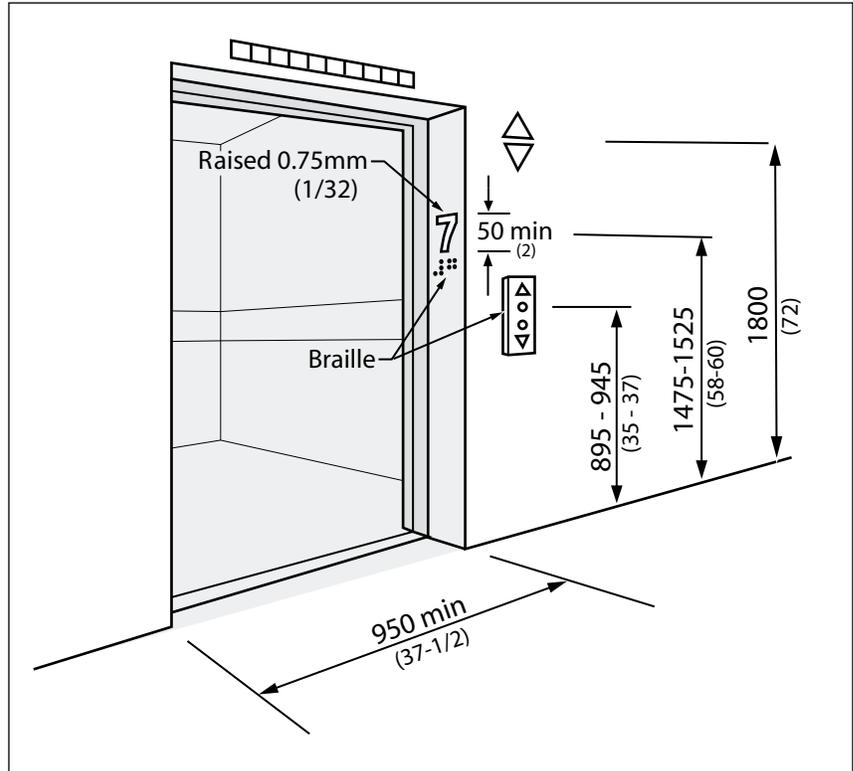

Figure 3.1.5.3 Elevator Entry

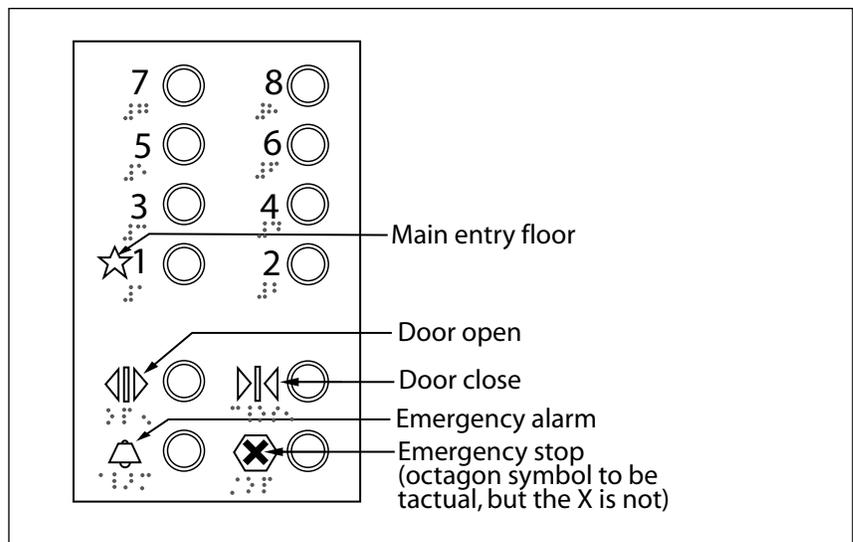

Figure 3.1.5.4 Tactile Symbols

3.1 INTERIOR ACCESS AND CIRCULATION

INTERIOR STANDARDS

3.1.5 Elevators (continued)

a minimum of 20 mm (13/16 in.) in size, mounted one above the other.

Hall visual indication shall be provided to show each call that is registered and that is extinguished when the call is answered.

Hall or in-car lanterns shall be provided. The centre line of the fixture shall be a minimum of 1830 mm (72 in.) above the floor. An audible signal shall be provided when the elevator stops at the landing. Visual *elements* shall be a minimum of 60 mm (2-3/8 in.) in the smallest direction.

All elevator hoist way *entrances* shall have raised Arabic numerals and Braille floor designations provided on at least one jamb. The characters shall be a minimum of 50 mm high (2 in.) and at least 0.75 mm (1/32 in.) shall be placed on both sides of the door jambs, with the centreline at 1500 ± 25 mm (59 ± 1 in.) from the floor.

As the car stops at a floor, the floor and direction of travel shall be announced using voice-annunciation technology.

Passenger elevators shall be linked by an emergency call system to a monitored location with two way communication ability. The highest *operable portion* of any two way communication system shall be a maximum of 1200 mm (47 in.) from the floor of the car. It shall be identified by a raised symbol and lettering located adjacent to the device.

The symbol shall be a minimum of 38 mm (1-1/2 in.) high and raised a minimum of 0.75 mm (1/32 in.). Permanently attached plates are acceptable. If the system uses a handset, then the length of the cord from the panel to the handset shall be at least 735 mm (29 in.). Additionally, the handset shall be equipped with a receiver that generates a magnetic field in the area of the receiver cap, and the handset shall have a volume control and shall comply with CSA Standard T515. If the system is located in a closed compartment, the compartment door and hardware shall conform to Section 3.5.1 Controls and Operating Mechanisms. The emergency intercommunication system shall not require voice communication. It may be in the form of a panic button.

Mirrors shall not be used below a height of 2000 mm (78-3/4 in.) within elevator cabs as a finish material on the wall *opposite* the door.

Where the dimension of elevator cabs is less than 1500 mm (59 in.) in any direction, an angled mirror shall be provided above a height of 2000 mm (78-3/4 in.) on the wall opposite the door, to assist persons who wheelchairs to back out.

Floor finishes within elevator cabs shall comply with Section 3.1.1 Interior Floor Finishes.

Elevator doors shall incorporate pronounced *colour contrast*,

to differentiate them from the surrounding environment.

There shall be a pronounced *colour contrast* between the car sill and the *facility* floor.

RELATED SECTIONS

- 1.1.1 Space and Reach Requirements
- 1.1.7 Handrails and Guards
- 1.2.1 Texture, Finishes and Colour
- 1.2.4 Signage
- 2.1.1 Exterior Ground Surfaces
- 2.1.2 Exterior Lighting
- 3.1.1 Interior Floor Surfaces
- 3.1.3 Doors
- 3.1.6 Platform Lifts
- 3.5.1 Controls and Operating Mechanisms
- 3.5.2 Card Access, Safety and Security Systems
- 3.5.3 Interior Lighting
- 3.5.4 Interior Glare and Light Sources

3.1.6 Platform Lifts

RATIONALE

Platform lifts are typical in *retro-fit* applications. Elevators that are used by all *facility* users are preferred to platform lifts which tend to segregate persons with *disabilities* and limit *space* at *entrance* and stair locations. Furthermore, independent access is often compromised, as platform lifts are often controlled by key operation. Whenever possible, grading or integrated elevator access should be incorporated to avoid the use of lifts.

If there are no suitable alternatives, lifts must be selected to permit the spatial requirement of larger mobility devices such as scooters.

APPLICATION

Platform lifts can not be located in exit stairs.

Accessible platform lifts shall comply with this section.

Platform lifts may only be used in lieu of an elevator or *ramp* where allowable under 3.1.5. Exception: Where it is *technically not feasible* to install an elevator or other *accessible* means of change of level.

DESIGN REQUIREMENTS

Accessible platform lifts shall

- be on an *accessible route* complying with 1.1.3;
- be identified with *signage*

complying with applicable provisions of 1.2.7;

- comply with CSA standard CAN/CSA B355 (latest edition); and
- allow for unassisted entry, operation, and exit from the lift.

The platform size shall be no less than 915 x 1525 mm (36 x 60 in.).

The doors to the platform lift shall comply with 3.1.3.

Controls and operating mechanisms shall comply with 3.3.2.

Platform lifts shall be linked by an emergency call system to a monitored location within the *facility*,

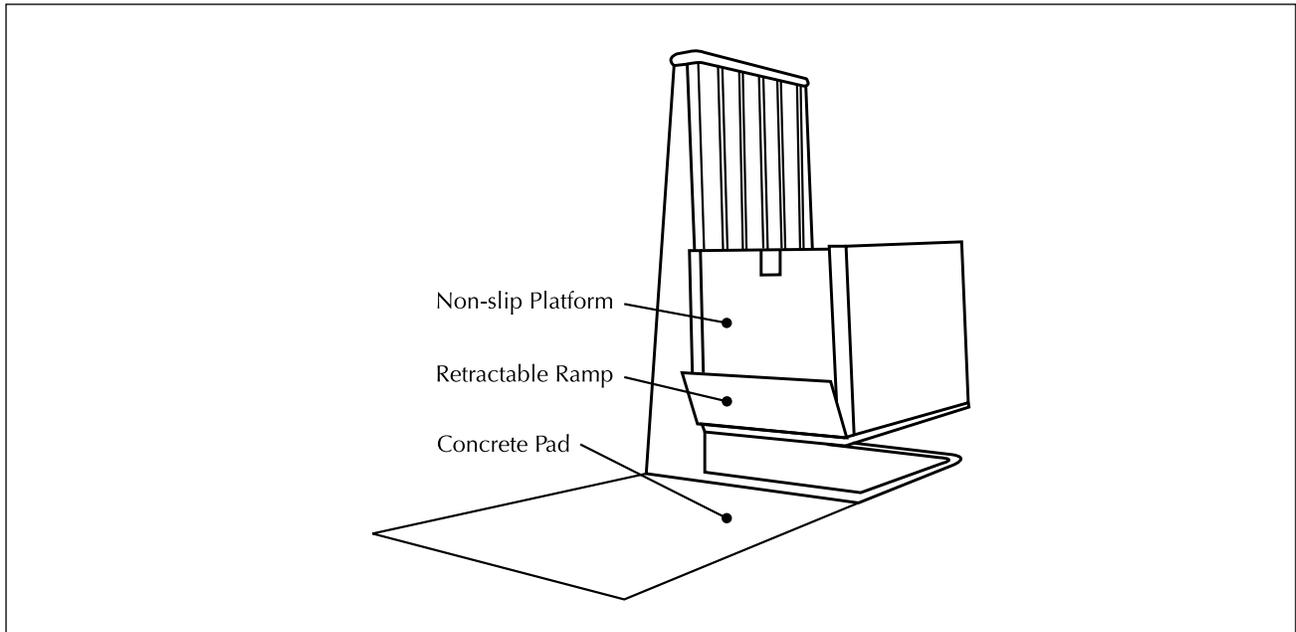

Figure 3.1.6.1 Vertical Platform Lift

3.1.6 Platform Lifts (continued)

with two way communication ability. The highest *operable portion* of the two way communication system shall be a maximum of 1200 mm (47 in.) from the floor of the car. If the system uses a handset, then the length of the cord from the panel to the handset shall be at least 735 mm (29 in.). If the system is located in a closed compartment, the compartment door and hardware shall conform to Section 3.5.1 Controls and Operating Mechanisms.

Floor finishes within platform lifts shall comply with Section 3.1.1 Interior Floor Finishes.

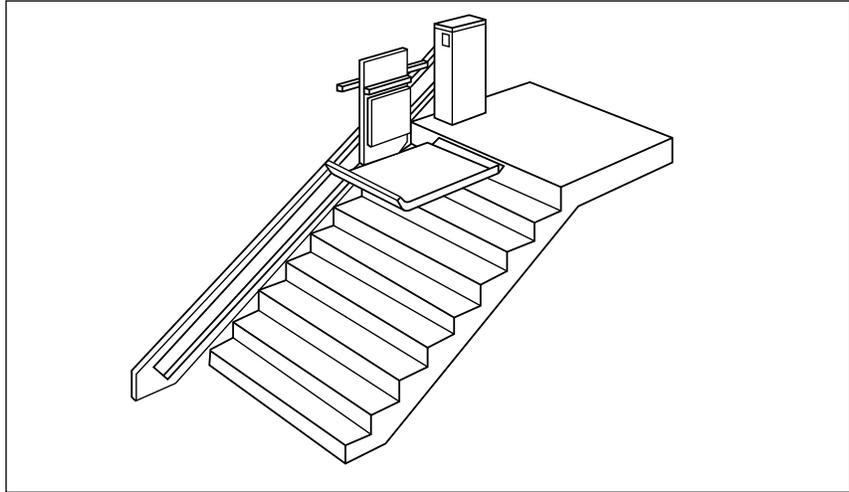

Figure 3.1.6.2 Inclined Platform Stair-Lift

RELATED SECTIONS

- 1.1.1 Space and Reach Requirements
- 1.1.7 Handrails and Guards
- 1.2.1 Texture, Finishes and Colour
- 1.2.4 Signage
- 2.1.1 Exterior Ground Surfaces
- 3.1.1 Interior Floor Surfaces
- 3.1.3 Doors
- 3.1.5 Elevators
- 3.5.1 Controls and Operating Mechanisms
- 3.5.2 Card Access, Safety and Security Systems
- 3.5.3 Interior Lighting
- 3.5.4 Interior Glare and Light Sources

3.1.7 Escalators

RATIONALE

Boarding and stepping off of an escalator can be challenging for many people. Lack of contrast on the edge of steps makes it difficult to determine the position of the steps or judge their speed. *Detectable warning surfaces* extending in front of the escalator provide warnings for any pedestrian, especially someone with a vision *impairment*. Contrasting colour strips on stair edges are also necessary.

APPLICATION

Escalators shall comply with this section.

DESIGN REQUIREMENTS

Escalator installations shall include high definition (*colour contrast*) of tread edges and nosing.

Detectable warning surfaces that comply with Section 1.2.6 Detectable Warning Surfaces shall be provided at the head and foot of the escalator.

The surface of escalator treads shall be in a matte finish, to minimize reflected glare.

Lighting over escalators shall be a minimum of 200 lux (18.4 ft-candles), evenly distributed, from a low-glare light source.

RELATED SECTIONS

- 1.1.1 Space and Reach Requirements
- 1.2.1 Texture, Finishes and Colour
- 1.2.4 Signage
- 1.2.6 Detectable Warning Surfaces
- 3.1.1 Interior Floor Surfaces
- 3.5.4 Interior Glare and Light Sources
- 3.1.2 Interior Lighting

3.1.8 Emergency Exits, Fire Evacuation and Areas of Rescue and Assistance

RATIONALE

In order to be *accessible* to all individuals, emergency exits must include the same accessibility features as other doors. The doors and routes must also be marked in a way that is *accessible* to all individuals, including those who may have difficulty with literacy, such as children or persons speaking a different language. In the event of fire when elevators cannot be used, areas of rescue assistance are an asset to anyone who would have difficulty traversing sets of stairs.

APPLICATION

The main floors of *facilities* required to be *accessible* shall incorporate *accessible means of egress* in the same number as required by the *MBC*.

Above the main level, where required exits from a floor level are not accessible, the only *means of egress* will be to an *area of rescue assistance*.

Areas of rescue assistance shall be provided on the floor level in a number equal to that of the required exits.

Every *occupiable* level in non-residential occupancies above or below the first *storey* (as defined by the *MBC*) that is *accessible*, shall

- be served by an elevator that has protection features, as specified in Section 3.3.1.7 of

the *MBC*; or

- be divided into at least two zones by fire separations, as specified in the *MBC*.

In *occupiable* levels above or below the first *storey* in residential occupancies, the requirements for a protected elevator or two fire zones may be waived, if an appropriate balcony, as specified in Section 3.3.1.7 of the *MBC*, is provided for each suite.

Areas of rescue assistance shall comply with this section.

A horizontal exit meeting the requirements of the *MBC* shall satisfy the requirements for an

area of rescue assistance.

DESIGN REQUIREMENTS

Where emergency warning systems are provided, then they shall include both audible alarms and visible alarms. Visual alarms shall comply with Section 3.4.1 Visual Alarms.

Accessible means of egress shall comply with Section 1.1.3 Accessible Routes, Paths and Corridors.

Accessible means of egress shall be identified with *signage* complying with applicable provisions of Section 1.2.4 Signage.

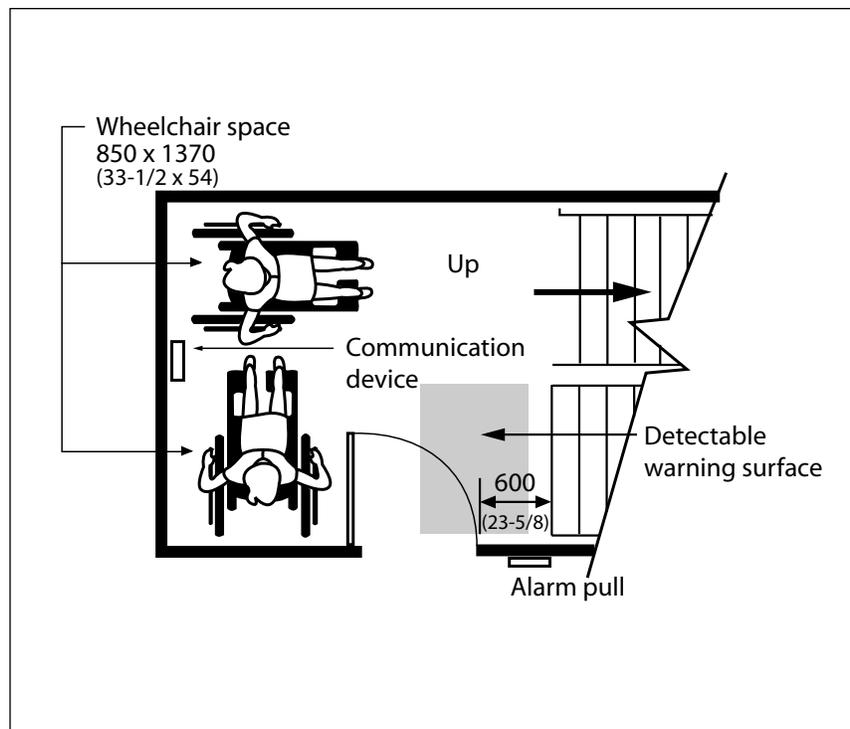

Figure 3.1.7.1 Area of Rescue Assistance

3.1.8 Emergency Exits, Fire Evacuation and Areas of Rescue and Assistance (continued)

Areas of rescue assistance shall

- be located on an *accessible route* complying with Section 1.1.3 Accessible Routes, Paths and Corridors;
- have a door in compliance with Section 3.1.3 Doors;
- incorporate the number of rescue spaces in accordance with Table 3.1.8;
- be of a size that allows a minimum floor *space* of 850 mm (33-1/2 in.) x 1370 mm (54 in.) per non-ambulatory occupant;
- be separated from the floor area by a fire separation having a fire-resistance rating at least equal to that required for an exit;
- be served by an exit or firefighter elevator;
- be designated as an *area of rescue assistance* for persons with *disabilities* on the *facility* plans and in the *facility*;
- be smoke protected in *facilities* of more than three *storeys*;
- incorporate a two way voice communication system for use between each *area of rescue assistance* and the central alarm and control *facility*;
- be identified with directional *signage* complying with applicable provisions of Section 1.2.4 Signage, stating 'Area of Rescue Assistance' and incorporate the international symbol for accessibility for *disabled* persons;
- be identified on all publicly

displayed floor evacuation plans;

- be identified on floor evacuation plans that are available in alternate formats; and
- be designated in evacuation procedure documents.

RELATED SECTIONS

All relevant parts of Sections 1.0 General Design Standards, 2.0 Exterior Design Standards and 3.0 Interior Design Standards.

Occupant load of the floor area served by the area of rescue assistance	Minimum number of rescue spaces
1 to 400	2
Over 400	3 plus 1 for each additional increment of 200 persons in excess of 400 persons

Table 3.1.7.1 Number of Rescue Spaces

3.2.1 Information, Reception and Service Counters

RATIONALE

Information, reception and service counters should be accessible to all visitors. A choice of counter heights is recommended to provide a range of options for a variety of persons. Lowered sections will serve children, persons of short stature and persons using wheelchairs. The choice of heights should also extend to speaking ports and writing surfaces. The provision of knee space under the counter facilitates use by a person using a wheelchair. The use of *colour contrast*, *tactile* difference or audio landmarks (e.g., receptionist voice or music source) can assist individuals with vision impairments to more precisely locate service counters or speaking ports.

In secure locations, there must be a balanced approach to safety, employee and customer reach ranges and access.

APPLICATION

Counters for information or service shall have at least one section usable by persons in wheelchairs. The service provider shall be at the same level as those being served.

DESIGN REQUIREMENTS

Information, reception and service counters shall be located on an *accessible route* complying with Section 1.1.3 Accessible Routes, Paths and Corridors.

Counters for information or service shall incorporate at least one *accessible* section that is located between 710 mm (28 in.) and 865 mm (34 in.) above the finished floor or ground. This section shall be at least 920 mm (36 in.) wide.

Accessible sections of information, reception and service counters shall have, on both sides of the counter, knee space below of at least 700 mm (27-1/2 in.) high by 500 mm (19-5/8 in.) deep.

Wheelchair seating spaces at *accessible* sections of information, reception and service counters shall incorporate a *clear space* not less than 760 mm (30 in.) by 1370 mm (54 in.).

Where a forward approach is used to access a wheelchair seat-

ing space, a *clear knee space* of at least 760 mm (30 in.) wide, 500 mm (19 5/8 in.) deep and 700 mm (27 1/2 in.) high shall be provided.

Where speaking ports are provided at information, reception or service counters, at least one such position should have a speaking port no higher than 1060 mm (42 in.) above the finished floor or ground.

If counter extension is used to accomplish adequate knee clearance, ensure it meets the requirements of Section 1.1.3 Accessible Routes, Paths and Corridors.

Point of sale mechanisms must be accessible (portable or reachable) to all users.

RELATED SECTIONS

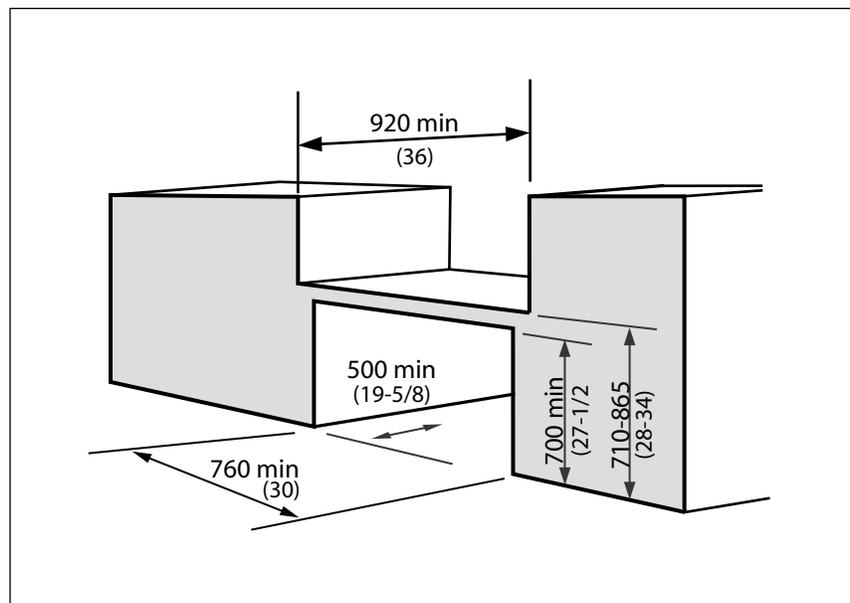

Figure 3.2.1.1 Service Counter

3.2.1 Information, Reception and Service Counters (continued)

- 1.1.1 Space and Reach Requirements
- 1.1.3 Accessible Routes, Paths and Corridors
- 1.2.1 Texture, Finishes and Colour
- 1.2.2 Acoustics
- 1.2.4 Signage
- 1.2.5 Information Systems
- 3.5.1 Controls and Operating Mechanisms
- 3.4.2 Assistive Listening Systems
- 3.5.3 Interior Lighting
- 3.5.4 Interior Glare and Light Sources

3.2.2 Tables, Counters and Work Surfaces

RATIONALE

Tables, counters and work surfaces should accommodate the needs of a range of users. Consideration should be given to standing-use as well as seated use. For individuals using wheelchairs, tables need to be high enough to provide knee space with enough clear space to pull into. The furniture placement at tables and maneuvering space at counters should provide sufficient turning space for a person using a wheelchair or scooter.

APPLICATION

If fixed or built-in tables, counters and work surfaces (including, but not limited to, dining tables and

study carrels) are provided in accessible public or common use areas, at least 10%, but not less than one, of the fixed or built-in tables, counters and work surfaces shall comply with this section.

DESIGN REQUIREMENTS

Accessible tables, counters and work surfaces shall be located on an accessible route complying with Section 1.1.3 Accessible Routes, Paths and Corridors.

An accessible route complying with Section 1.1.3 Accessible Routes, Paths and Corridors shall lead to and around such fixed or built-in tables, counters and work surfaces.

Wheelchair seating spaces at accessible tables, counters and work surfaces shall incorporate a clear space of not less than 900 mm (35-1/2 in.) by 1500 mm (59 in.).

Where a forward approach is used to access a wheelchair seating space, a clear knee space of at least 800 mm (31-1/2 in.) wide, 500 mm (19-5/8 in.) deep and 700 mm (27-1/2 in.) high shall be provided. It may overlap the clear space by a maximum of 500 mm (19-5/8 in.).

The top of accessible tables, counters and work surfaces shall be located between 710 mm (28 in.) to 850 mm (33-1/2 in.) above the finished floor or ground.

Cabinets shall

- incorporate doors that are colour contrasted; and
- incorporate hardware that is colour contrasted to the doors, and is in compliance with Section 3.5.1 Controls and Operating Mechanisms.

RELATED SECTIONS

- 1.1.1 Space and Reach Requirements
- 1.1.3 Accessible Routes, Paths and Corridors

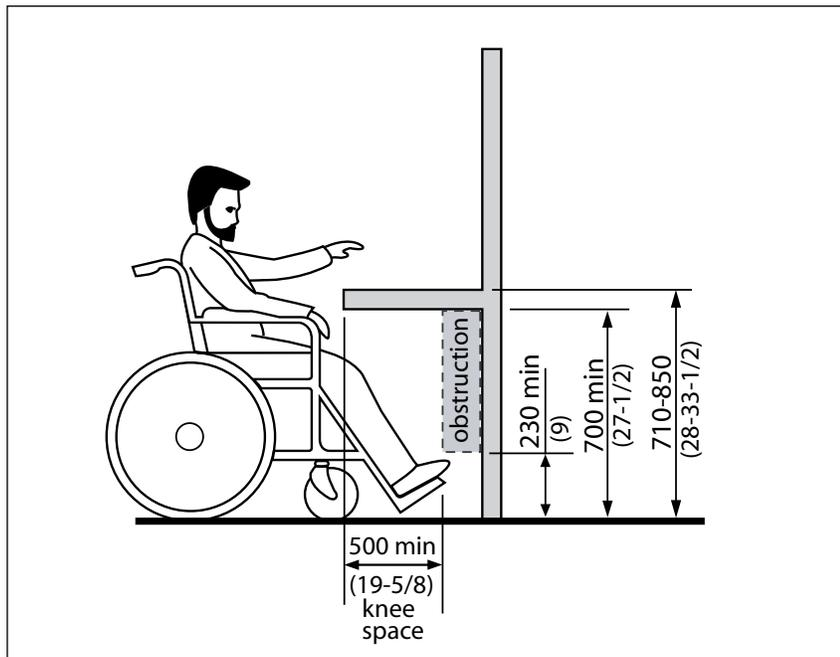

Figure 3.2.2.1 Table, Counter and Work Surface Clearance

3.2.2 Tables, Counters and Work Surfaces (continued)

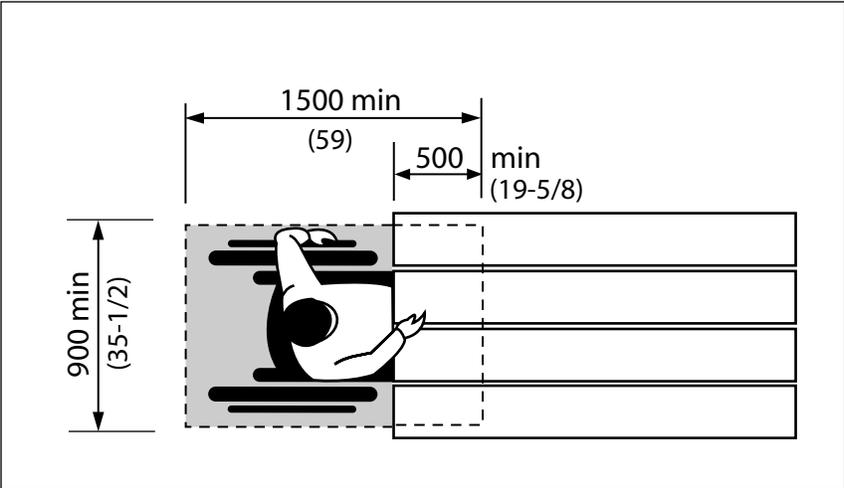

Figure 3.2.2.2 Frontal Approach

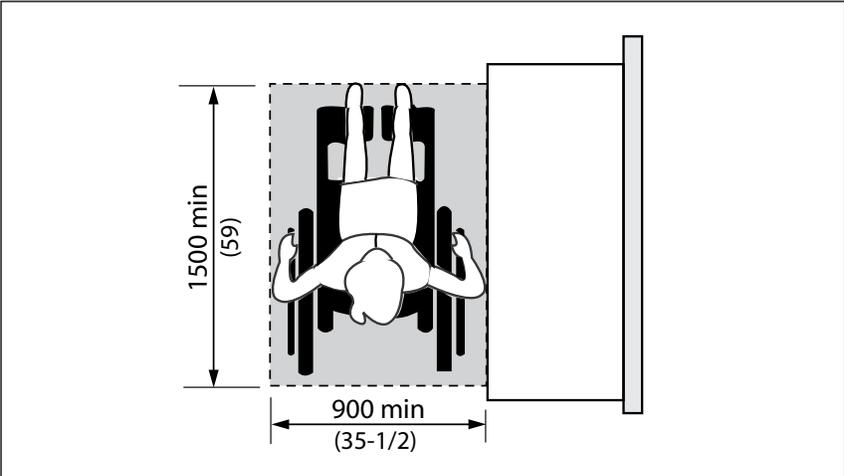

Figure 3.2.2.3 Parallel Approach

3.2 INTERIOR AMENITIES

3.2.3 Offices, Work Areas and Meeting Rooms

RATIONALE

Offices should be *accessible* to all people, both staff and visitors, regardless of mobility. If it is *technically infeasible* to have all *offices* accessible, at least 25% of the total offices shall be meet the requirements of this section.

All persons, but particularly those with a hearing *impairment*, would benefit from having a quiet acoustic environment - background noise from mechanical equipment such as fans, should be minimal. Telephone equipment for individuals with hearing *impairments* may also be required.

Tables and workstations should address the knee *space* requirements of an individual in a wheelchair. Circulation areas also need to consider the spatial needs of mobility equipment as large as scooters.

Natural coloured task lighting is a design feature that will facilitate use by all, especially persons with vision *impairments*. In locations where reflective glare might be problematic, such as large expanses of glass with reflective flooring, consideration should be given to providing blinds that can be louvered upwards.

APPLICATION

Wherever offices, work areas or *meeting rooms* are provided for use by the general public, employees, clients or customers, they shall comply with this section.

DESIGN REQUIREMENTS

Where offices, work areas and *meeting rooms* are provided for use by the general public, employees, clients or customers, they shall

- be located on an *accessible route* complying with Section 1.1.3 Accessible Routes, Paths and Corridors;
- where equipped with a door, the door shall comply with Section 3.1.3 Doors;
- incorporate a *clear space* allowing a person in a wheelchair to make a 180-degree turn;
- incorporate an *accessible route* through the *space* that does not require the person in a wheelchair to travel backwards to enter/leave the *space*;
- incorporate an *accessible route* in compliance with 1.1.3 that connects the primary activity *elements* within the office, work area or *meeting room*;
- incorporate knee clearances below work surfaces that comply with Section 3.2.2 Tables, Counters and Work Surfaces;
- incorporate access in compliance with Section 3.2.5 Storage, Shelving and Display Units for storage, shelving or display units for use by the general public, clients or customers;
- provide a *clear space* in front of the equipment that complies

with Section 1.1.1 Space and Reach Requirements, where equipment such as photocopiers are provided for use by the general public, clients or customers; and

- be equipped with an assistive listening system that complies with Section 3.4.2 Assistive Listening Systems, where an assistive listening system is required.

RELATED SECTIONS

All relevant parts of Sections 1.0 General Design Standards, 2.0 Exterior Design Standards and 3.0 Interior Design Standards.

3.2.4 Kitchens and Kitchenettes

RATIONALE

Kitchens, kitchenettes and coffee stations require an appropriate level of access to be usable by persons with *disabilities*. Adequate maneuvering space is required for users of mobility equipment to approach and use work surfaces, storage *elements* and appliances.

A frontal approach to work surfaces and appliances is generally preferred, except at refrigerators where a side approach is preferred. Where a frontal approach is used, knee space and toe space are required.

The use of *colour contrast* between kitchen *elements* will assist persons with low vision locate surfaces, appliances and controls. Darker coloured work surfaces are preferable as they make it easier to identify objects located on them.

APPLICATION

Kitchens and kitchenettes intended for use by staff or the public shall comply with this section. Exception: Commercial kitchens.

At least 50% of shelf *space* in storage facilities shall comply with this section.

DESIGN REQUIREMENTS

Pass-through kitchens shall have

- where counters, appliances or cabinets are on two opposing sides, or when counters,

- appliances or cabinets are opposite a parallel wall, clearance between all opposing base cabinets, counter tops, appliances, or walls within a kitchen work area of 1100 mm (43-1/4 in.) minimum; and
- two entries.

U-shaped kitchens enclosed on three continuous sides shall have a minimum clearance of 2440 mm (96 in.) between all opposing base cabinets, counter tops, appliances, or walls within kitchen work areas. In a *retrofit* situation where providing a 2440 mm (96 in.) *space* is *technically not feasible*, this *space* may be reduced to 2130 mm (84 in.).

Storage *elements* shall

- be located on an accessible route with adjacent *clear space* in compliance with Section 1.1.1 Space and Reach Requirements;
- comply with at least one of the reach ranges specified in Section 1.1.1 Space and Reach Requirements; and
- incorporate *operable portions* in compliance with Section 3.5.1 Control and Operating Mechanisms.

Kitchen sinks shall

- be located on an accessible route with adjacent *clear space* for a forward approach. Exceptions: A parallel approach is permitted to a kitchen sink where a cook

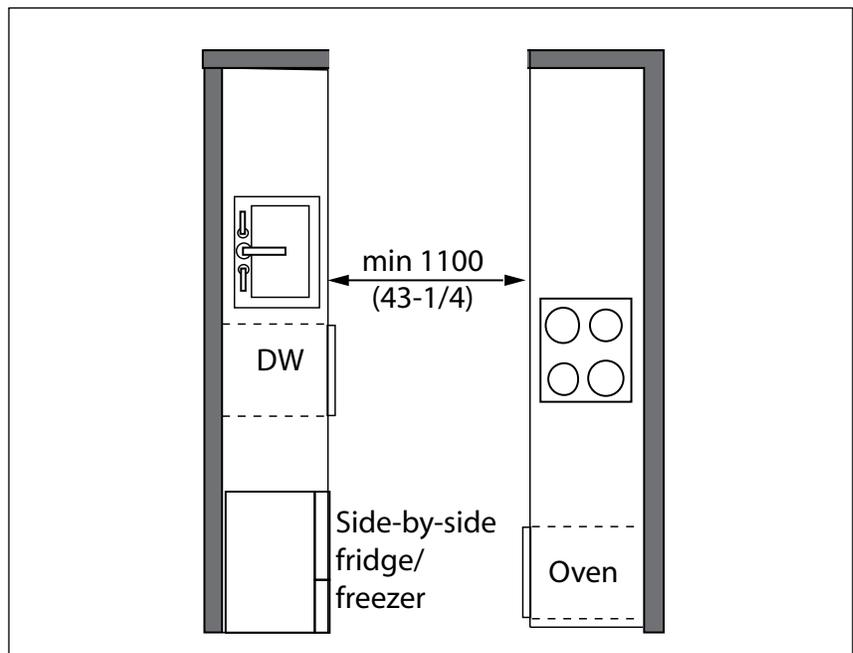

Figure 3.2.4.1 Pass-Through Kitchen

3.2 INTERIOR AMENITIES

INTERIOR STANDARDS

3.2.4 Kitchens and Kitchenettes (continued)

- top or conventional range is not provided and to wet bars;
- where a forward approach is provided, incorporate knee space below at least 760 mm (30 in.) wide, 480 mm (18-7/8 in.) deep, and 685 mm (27 in.) high;
- have the height of the rim or the counter top (whichever is higher) 710 mm – 856 mm (28 in. – 34 in.);
- incorporate faucets and other controls in compliance with Section 3.5.1 Controls and Operating Mechanisms;
- have water supply and drain pipes under the sink insulated or otherwise configured to protect against contact; and
- incorporate no sharp or abra-

sive surfaces under the sink.
Kitchen appliances shall

- be located on an accessible route with adjacent *clear space* in compliance with Section 1.1.1 Space and Reach Requirements; and
- incorporate controls and *operable portions* in compliance with Section 3.5.1 Controls and Operating Mechanisms. Exceptions: Appliance doors and door latching devices.

Dishwashers shall incorporate *clear space* adjacent to the dishwasher door. The dishwasher door, in the open position, shall not obstruct the *clear space* for

the dishwasher or the sink.

Ranges and cooktops shall

- incorporate controls that are located to avoid reaching across the burners; and
- where a forward approach is provided
 - incorporate knee space below at least 760 mm (30 in.) wide, 480 mm (18-7/8 in.) deep, and 700 mm (27-1/2 in.) high; and
 - insulate or otherwise configure the appliance to prevent burns, abrasions, or electrical shock.

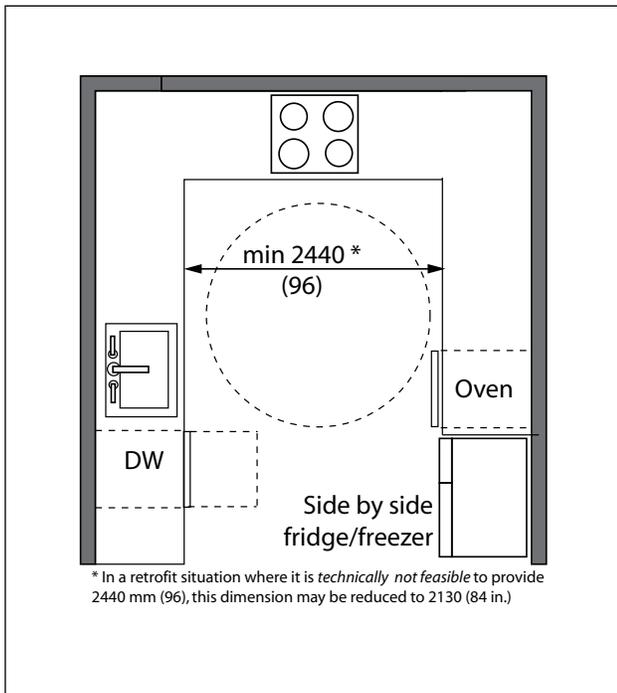

Figure 3.2.4.2 U-Shaped Kitchen

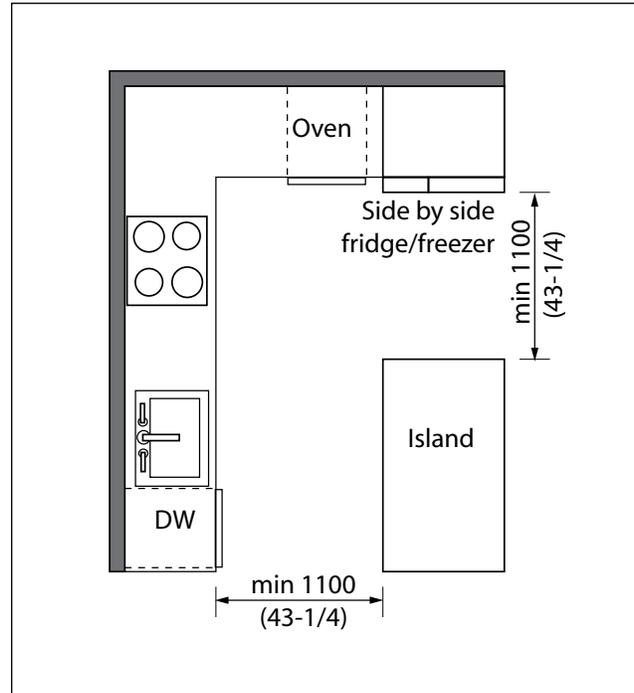

Figure 3.2.4.3 L-Shaped Kitchen with Island

3.2 INTERIOR AMENITIES

3.2.4 Kitchens and Kitchenettes (continued)

Ovens shall

- have controls located on the front panels, mounted no higher than 1400 mm (55-1/8 in.);
- where side-hinged doors are used, be located
- with an adjacent work surface positioned adjacent to the latch side of the door; and
- incorporate a pull-out shelf below the oven; and
- where bottom-hinged doors are used, be located with an adjacent work surface positioned adjacent to one side of the door.

All cooking appliances within program areas or rooms being utilized by children should have a secure means of disconnecting power units.

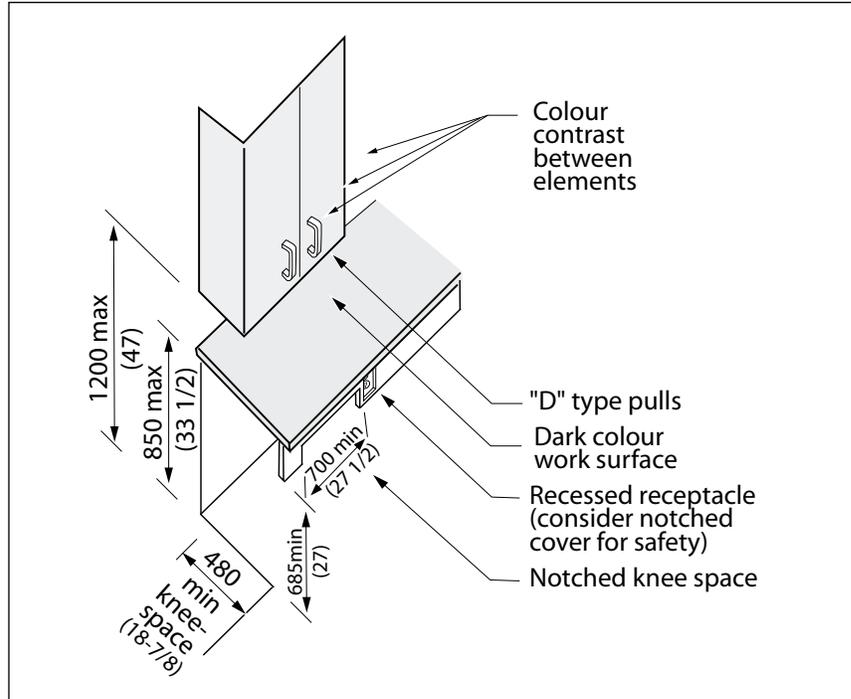

Figure 3.2.4.4 Storage Elements

Refrigerators/freezers shall

- be configured with at least 50% of the freezer space maximum 1370 mm (54 in.) above the floor; and
- incorporate clear space in front, positioned for a parallel approach immediately adjacent to the refrigerator/freezer, with the centre-line of the clear space offset 610 mm (24 in.) maximum from the front face of the refrigerator/freezer.

All kitchen elements shall incorporate colour contrast to visually differentiate the cabinets and appliances from adjacent wall and floor surfaces, the countertop

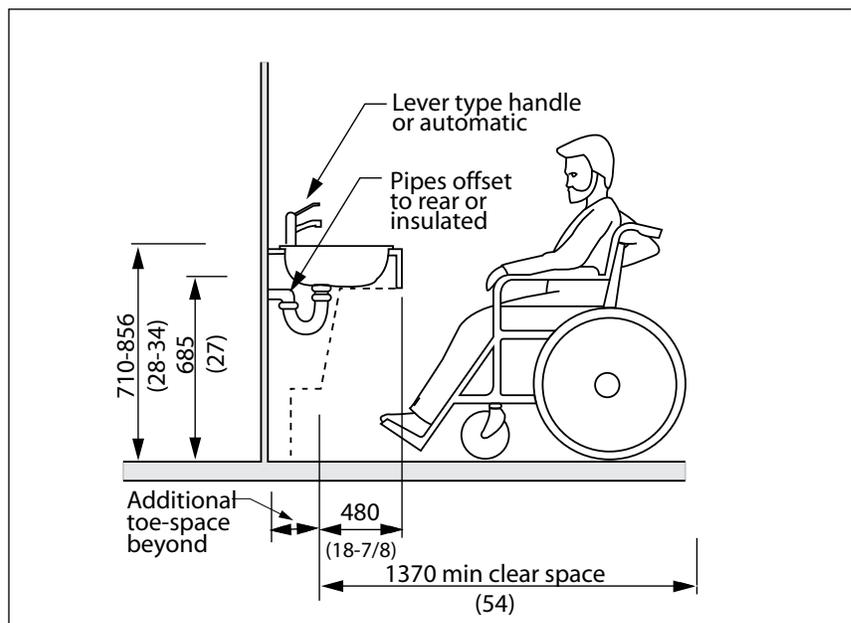

Figure 3.2.4.5 Accessible Kitchen Sink

3.2 INTERIOR AMENITIES

3.2.4 Kitchens and Kitchenettes (continued)

from the cabinets and adjacent walls, and operable hardware on cabinets.

RELATED SECTIONS

- 1.1.1 Space and Reach Requirements
- 1.1.2 Protruding and Overhead Objects
- 1.1.3 Accessible Routes, Paths and Corridors
- 1.2.1 Texture, Finishes and Colour
- 3.1.1 Interior Floor Surfaces
- 3.5.3 Interior Lighting
- 3.5.4 Interior Glare and Light Sources

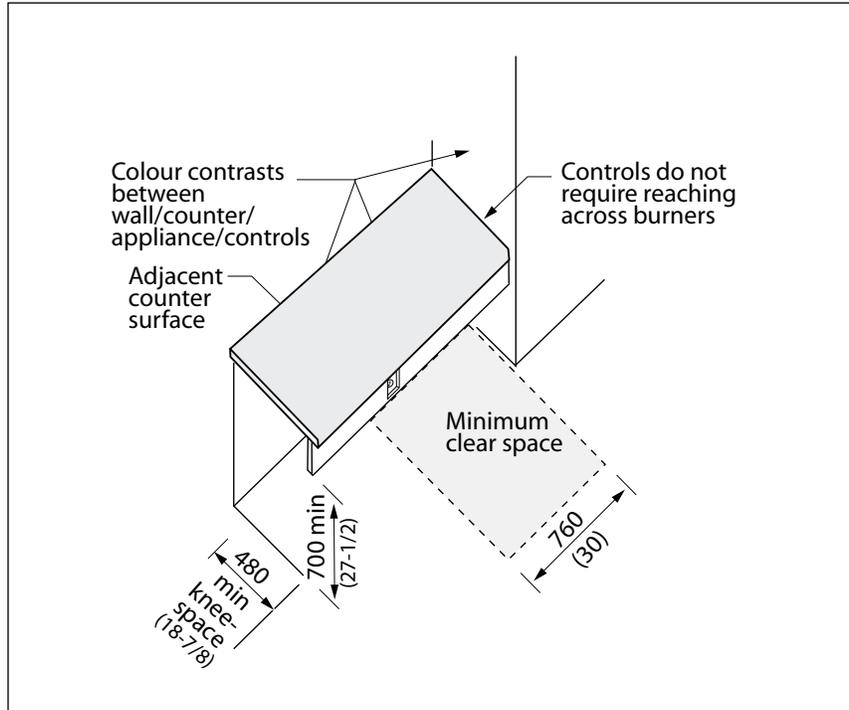

Figure 3.2.4.6 Accessible Cook Top

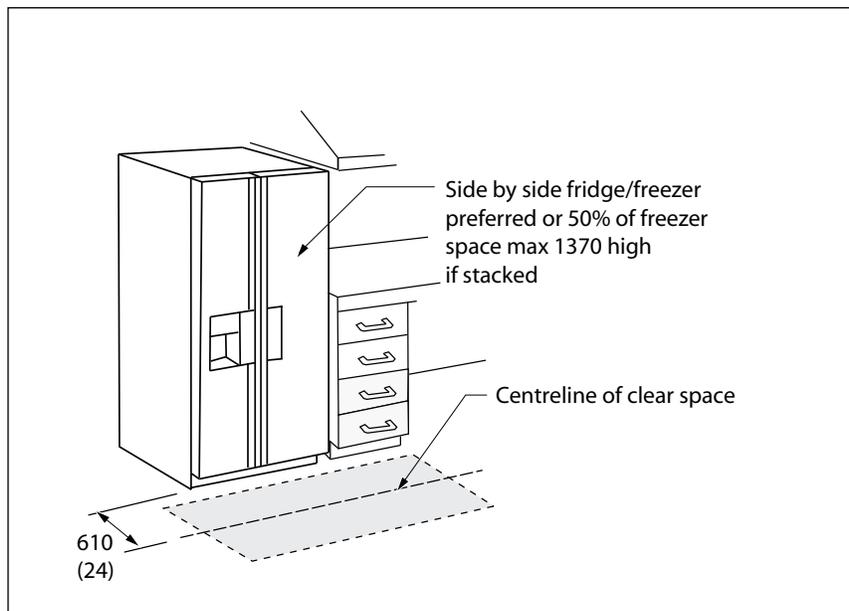

Figure 3.2.4.7 Accessible Fridge/Freezer

3.2.4 Kitchens and Kitchenettes (continued)

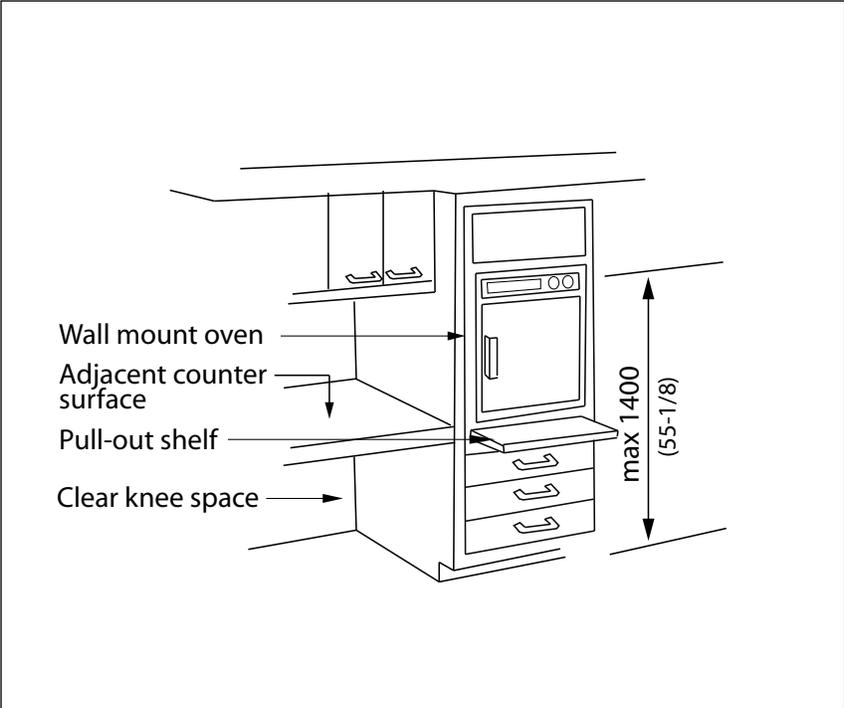

Figure 3.2.4.8 Accessible Wall-Mounted Oven

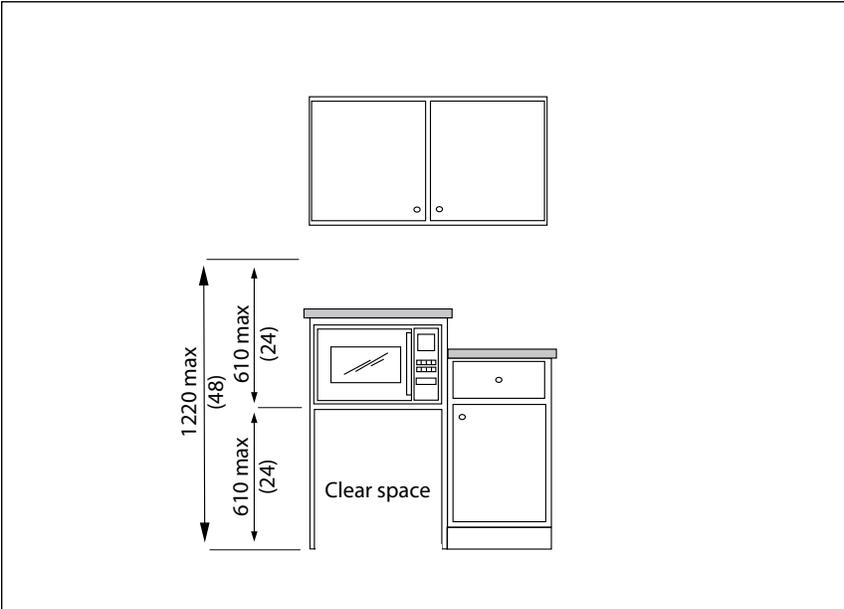

Figure 3.2.4.9 Accessible Microwave

3.2 INTERIOR AMENITIES

3.2.5 Storage, Shelving and Display Units

RATIONALE

The heights of storage, shelving and display units should address a full range of vantage points including the lower sight lines of children or persons using wheelchairs. The lower heights also serve the lower reach of these individuals. Displays that are too low can be problematic for individuals that have difficulty bending down. Appropriate lighting and *colour contrast* is particularly important for individuals with vision *impairments*.

APPLICATION

If fixed or built-in storage *facilities*, such as cabinets, closets, shelves and drawers, are provided in *accessible spaces*, at least one of each type provided shall contain storage *space* complying with this section. This includes media dis-

plays areas for brochures, drop-boxes and mail slots.

Shelves or display units allowing self-service by customers shall be located on an *accessible route* complying with Section 1.1.3 Accessible Routes, Paths and Corridors.

DESIGN REQUIREMENTS

A *clear space* at least 760 mm (30 in.) by 1370 mm (54 in.) complying with Section 1.1.1 Space and Reach Requirements that allows either forward or parallel approach by a person using a wheelchair shall be provided at *accessible storage facilities*.

Accessible storage spaces shall be within at least one of the reach ranges specified in Section 1.1.1 Space and Reach Requirements. Clothes rods or shelves shall be

a maximum of 1370 mm (54 in.) above the finished floor for a side approach. Where the distance from the wheelchair to the clothes rod or shelf is 255 mm – 535 mm (10 in. - 21 in.) (as in closets without *accessible doors*) the height of the rod or shelf shall be no more than 1200 mm (47 in.).

Hardware for *accessible storage facilities* shall comply with Section 3.5.1 Controls and Operating Mechanisms. Touch latches and U-shaped pulls are acceptable

RELATED SECTIONS

- 1.1.1 Space and Reach Requirements
- 1.1.3 Accessible Routes, Paths and Corridors
- 3.5.1 Controls and Operating Mechanisms

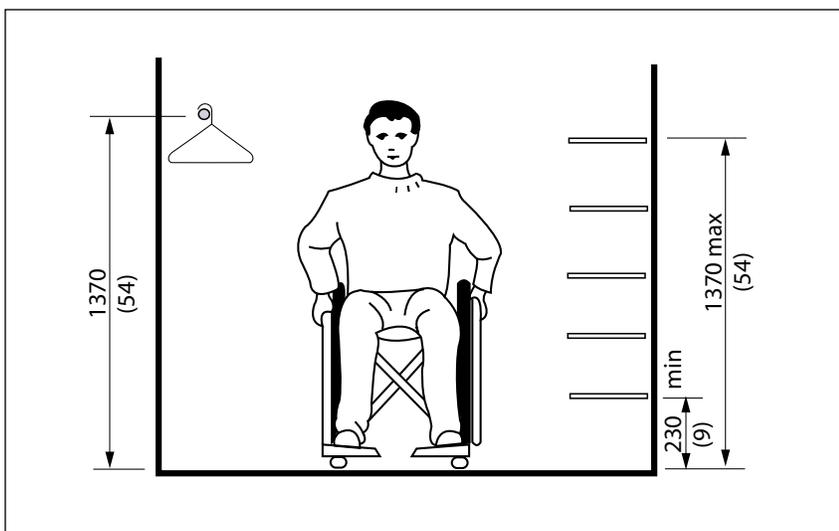

Figure 3.2.5.1 Reach Limits for Storage

3.2.6 Specialty Change Rooms

RATIONALE

In addition to *accessible common use* dressing rooms, a separate unisex dressing room is useful. This is valuable in a scenario where an attendant of the opposite sex or a parent is assisting a child. Sufficient space should be allowed for two people and a wheelchair, along with benches and accessories.

The provision of *handrails* along circulation routes from dressing rooms to pool, gymnasium and other activity areas, will be of benefit to many people.

APPLICATION

Where dressing rooms are provided for use by the general public, patients, customers or employees, they shall comply with this section. In a *retrofit* situation where it is *technically not feasible* to have all dressing rooms comply with this section, 10% of dressing rooms, but never less than one, for each type of use in each cluster of dressing rooms shall be *accessible* and comply with this section.

Where a facility incorporates multi-user dressing rooms with integral washroom and shower facilities, at least 10% of the multi-user dressing rooms, but never less than one, shall incorporate a private dressing room in compliance with this section.

DESIGN REQUIREMENTS

Accessible dressing rooms shall be located on an *accessible route* complying with Section 1.1.3 Accessible Routes, Paths and Corridors.

All *accessible* dressing rooms shall include an emergency call station that activates an external light above the door to alert persons to emergency situations.

A *clear space* allowing a person using a wheelchair to make a 180-degree turn shall be provided within every *accessible* dressing room, accessed through either a hinged or sliding door. No door shall swing into any part of the required turning *space* within the dressing room. Turning *space* is not required within a private dressing room accessed through a curtained opening at least 950 mm (37-1/2 in.) wide, if *clear space* complying with Section 1.1.1 Space and Reach Requirements renders the dressing room usable by a person in a wheelchair.

All doors to *accessible* dressing rooms shall be in compliance with Section 3.1.3 Doors. Outward swinging doors shall not constitute a hazard to persons using adjacent circulation routes and they shall be power operated.

Every *accessible* dressing room shall have a 760 mm (30 in.) x 1830 mm (72 in.) bench fixed to the wall along the longer dimension. The bench shall

- be mounted 450 mm - 500 mm (17-3/4 in. - 19-5/8 in.) above the finished floor;
- have *clear space* provided alongside the bench to allow a person using a wheelchair to make a parallel transfer onto the bench;
- be designed to carry a minimum load of 2.66 kN (600 lb.); and
- where installed in conjunction with showers, swimming pools, or other wet locations, be designed so that
 - water shall not accumulate upon the surface of the bench; and
 - have a slip-resistant top surface.

The *accessible* change bench shall be equipped with a grab bar that

- complies with Section 3.3.8 Grab Bars; and
- is L-shaped with 760 mm (30 in.) long horizontal and vertical components mounted with the horizontal component 630 mm - 690 mm (24-3/4 in. - 27-1/8 in.) above the floor and the vertical component 150 mm (6 in.) in front of the bench.

At least one waste receptacle, collapsible coat hook and shelf must be reachable from the *accessible* bench.

Where mirrors are provided in dressing rooms of the same use, then in an *accessible* dressing room, a full-length mirror measuring at least 460 mm (18 in.) wide

3.2.6 Specialty Change Rooms (continued)

by 1370 mm (54 in.) high shall be mounted in a position affording a view to a person on the bench, as well as to a person in a standing position.

1.2.1 Texture, Finishes and Colour

Dressing rooms shall incorporate even illumination throughout of at least 100 lux (10 ft-candles).

RELATED SECTIONS

- 1.1.1 Space and Reach Requirements
- 1.1.2 Protruding and Overhead Objects
- 1.1.3 Accessible Routes, Paths and Corridors

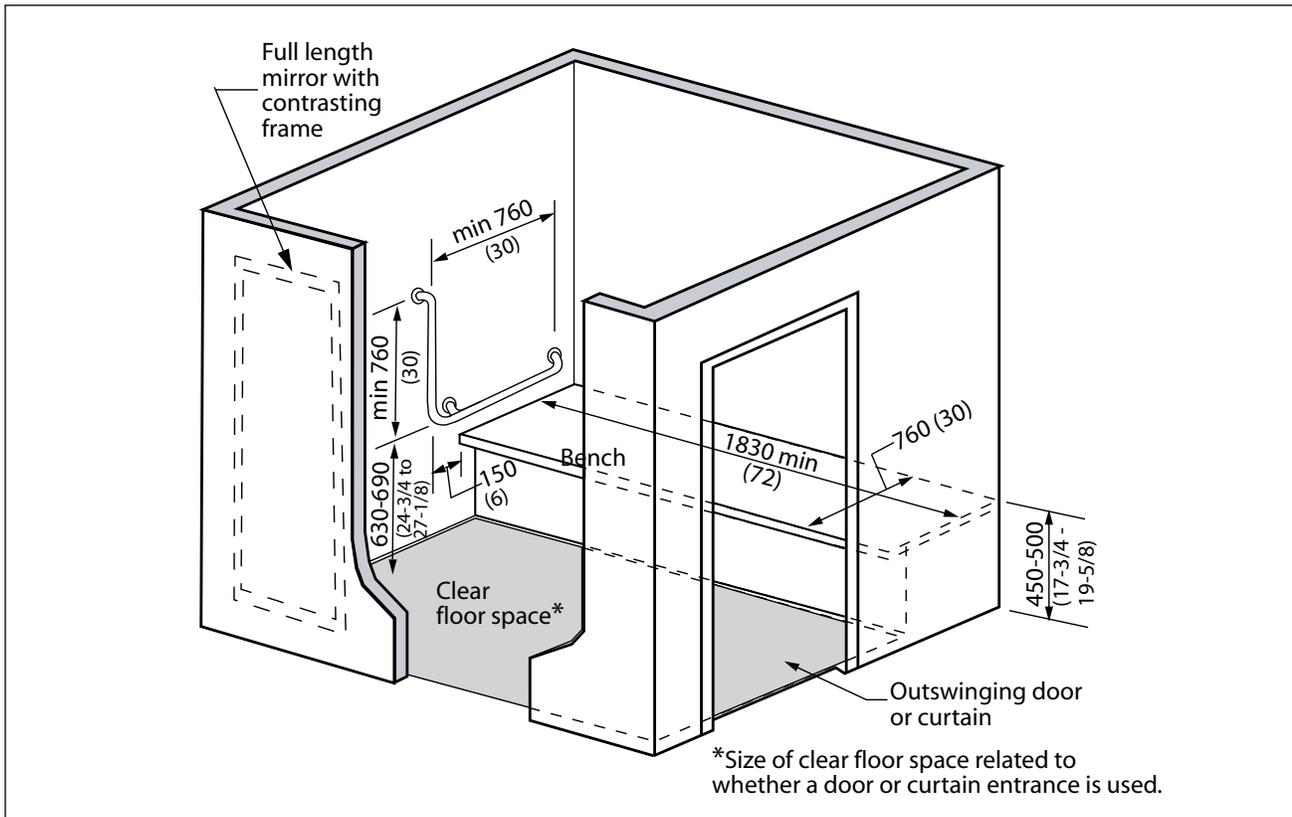

Figure 3.2.6.1 Accessible Dressing Room

3.2.7 Lockers and Storage Units

RATIONALE

In training, recreational, and transit facilities, or wherever public or private storage lockers are provided, at least some of the storage units should be usable by persons using wheelchairs.

Lockers designed specifically for universal design applications are preferred.

The provision of lockers at lower heights serves the reach restrictions of children or persons using wheelchairs. The operating mechanisms should also be at an appropriate height and operable by individuals with restrictions in hand dexterity.

APPLICATION

If lockers or baggage storage units are provided in *accessible* public or *common use* areas, at least 10%, but not less than one, of the lockers or baggage storage units shall comply with this section.

DESIGN REQUIREMENTS

Accessible locker units shall be located on an *accessible route* complying with Section 1.1.3 Accessible Routes, Paths and Corridors.

Accessible locker units shall be *colour contrasted* to other lockers.

Locker units shall have their bottom shelf no lower than 400

mm (15-3/4 in.) and their top shelf no higher than 1370 mm (54 in.) above the floor or ground.

Locks for *accessible* locker units shall be mounted no higher than 1060 mm (42 in.) from the floor or ground and shall comply with Section 3.5.1 Control and Operating Mechanisms.

Numbers or names on locker units should be in clearly legible lettering, raised and of a highly contrasting colour or tone in compliance with the relevant parts of Section 1.2.4 Signage.

Aisle *spaces* in front of lockers and storage units shall be a minimum of 1370 mm (54 in.) deep to permit forward and lateral approach by wheelchair users.

- 1.2.1 Texture, Finishes and Colour
- 1.2.4 Signage
- 2.1.2 Exterior Lighting
- 3.5.1 Controls and Operating Mechanisms
- 3.5.3 Interior Lighting

RELATED SECTIONS

- 1.1.1 Space and Reach Requirements
- 1.1.3 Accessible Routes, Paths and Corridors

Total number of lockers	Minumum number of accessible lockers
1-5	1
6-10	2
11-25	4
26-35	6
36+	10

Table 3.2.7.1 Accessible Locker Requirements

3.2 INTERIOR AMENITIES

INTERIOR STANDARDS

3.3.1 Toilet and Bathing Facilities

RATIONALE

As an integral feature of a *facility*, washroom *facilities* should accommodate the range of people that will use the *space*. In some cases, a person with a *disability* may require assistance to use toilet and bathing *facilities*. Where the individual providing assistance is of the opposite gender then typical gender-specific washrooms are awkward and an individual washroom is preferred.

Wet surfaces and the act of transferring between toilet and wheelchair can make bathrooms accident-prone areas. Therefore, emergency call switches may ensure related response procedures. The appropriate design of all features will increase the usability and safety of the *space*.

Signs that are used to identify washrooms should consider the needs of a variety of users. For children or someone who cannot read text, a symbol is preferred.

A person with a vision *impairment* would also benefit from accessible *signage*. Features such as *colour contrasting* door frames and door hardware will also increase accessibility.

Washroom *entrances* that do not incorporate doors are preferred.

APPLICATION

Where toilet *facilities* are provided, each public or *common use* toilet *facility* shall comply with

this section. Other toilet rooms provided for the use of occupants of specific *spaces* (i.e., a private toilet room for the occupant of a private office) shall be *adaptable*.

In a *retrofit* situation where it is *technically not feasible* to make existing public or *common use* toilet *facilities* accessible, the installation of at least one individual washroom per floor complying with Section 3.3.7 Individual

Washrooms, preferably located adjacent to the other existing toilet *facilities*, will be permitted in lieu of modifying existing toilet *facilities* to be *accessible*.

In *addition* to any *accessible* public or *common use* toilets, at least one individual washroom complying with Section 3.3.7 Individual Washrooms shall be provided in a public area of all public *buildings*.

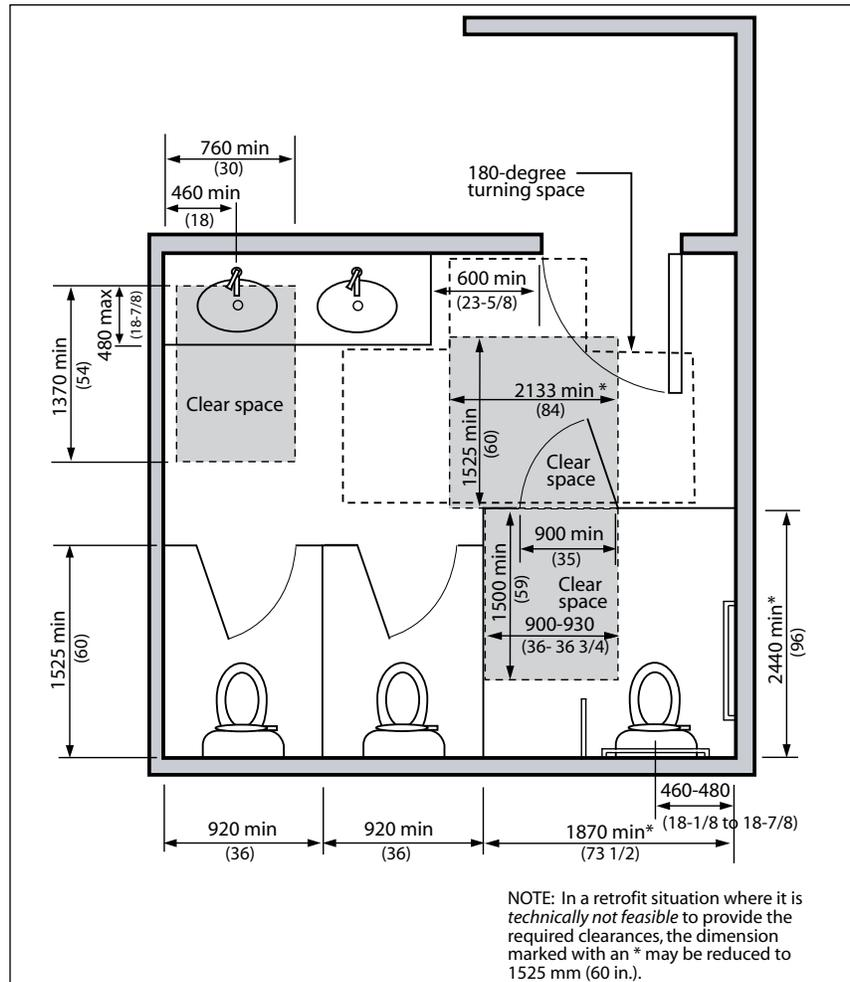

Figure 3.3.1.1 Washroom Dimensions

3.3 WASHROOM FACILITIES

3.3.1 Toilet and Bathing Facilities (continued)

In *addition* to any *accessible* public or *common use* toilets, at least one individual washroom complying with Section 3.3.7 Individual Washrooms shall be provided on every floor in *assembly areas* where the floor incorporates *common* or *public use* washroom containing four or more toilet and/or urinal fixtures.

If individual washrooms are not visible from the common or *public use* washrooms, directional *signage* complying with section 3.3.7 Individual Washrooms, shall be provided.

For single-user portable toilets or clustered at a single location, at least 5%, but no less than one, toilet complying with this section shall be provided at cluster wherever typical inaccessible units are provided. Exception: Portable toilet units at construction *sites* used exclusively by construction personnel are not required to comply with this section.

Where an individual washroom is provided primarily for the use of persons of both sexes with physical *disabilities*, in lieu of *facilities* for persons with physical *disabilities* in washrooms used by the general public, the individual washroom shall be provided on the same floor level within 15 m (50 ft.) of the washrooms used by the general public.

DESIGN REQUIREMENTS

Accessible toilet and bathing *facilities* shall be on an *accessi-*

ble route complying with Section 1.1.3 Accessible Routes, Paths and Corridors.

All doors to *accessible* toilet and bathing rooms shall comply with Section 3.1.3 Doors. Doors shall not swing into the *clear space* required for any fixture.

The *accessible* fixtures and controls within toilet and bathing *facilities* shall be located on an *accessible route* which is at least 1200 mm (47-1/4 in.) wide and in compliance with Section 1.1.3 Accessible Routes, Paths and Corridors.

Toilet and bathing *facilities* shall incorporate a *clear space*, in compliance with 1.1.1 Space and Reach Requirements, in front of *accessible* toilet stall doors and in front of *accessible* lavatories to allow a person in a wheelchair or scooter to make a 180-degree turn.

Accessible toilet and bathing *facilities* shall be identified with *signage* complying with applicable provisions of Section 1.2.4 Signage.

Toilet and bathing facilities shall incorporate even illumination throughout of at least 100 lux (10 ft-candles).

An infant changing area shall be provided in single occupant washrooms and multiple occupant washrooms (both male and female). In multiple occupant washrooms they shall be located

outside of the accessible stall.

The infant changing station shall comply with Sections 1.1.1 General Space and Reach Requirements, 1.1.2 Protruding and Overhead Objects, and 3.5.1 Controls and Operating Mechanisms.

To be accessible they must allow for clear space complying Figure 3.3.1.1 and Figures 1.1.1.13 – 1.1.1.15 Wheelchair Forward Reach Allowances, and Figure 3.2.2.1 Table, Counter and Work Surface Clearance. The top surface should be 700 mm (27 in.) minimum and 865 mm (34 in.) maximum in height above the finished floor. They shall be a minimum of 915 mm (36 in.) long and 610 mm (24 in.) deep.

RELATED SECTIONS

- 1.1.1 Space and Reach Requirements
- 1.1.2 Protruding and Overhead Objects
- 1.2.1 Texture, Finishes and Colour
- 1.2.4 Signage
- 2.1.1 Exterior Ground Surfaces
- 3.1.3 Doors
- 3.3.2 Toilet Stalls
- 3.3.3 Toilets
- 3.3.4 Lavatories
- 3.3.5 Urinals
- 3.3.6 Washroom Accessories
- 3.3.7 Individual Washrooms
- 3.3.8 Grab Bars
- 3.3.9 Shower Stalls
- 3.4.1 Visual Alarms
- 3.5.1 Controls and Operating Mechanisms
- 3.5.3 Interior Lighting

INTERIOR STANDARDS

3.3.2 Toilet Stalls

RATIONALE

Maneuverability of a wheelchair or scooter is a principal consideration in the design of an accessible stall. The increased size of the stall is required to ensure there is sufficient *space* to facilitate the proper placement of a wheelchair or scooter to accommodate a transfer onto the toilet fixture. Not only is *space* required for the mobility equipment but there may also be instances where an individual requires assistance and the stall will have to accommodate a second person.

Door swings are normally outward for safety reasons and *space* considerations, but this makes it difficult to close the door once inside. A handle mounted part way along the door makes it easier for someone to close the door behind them.

Minimum requirements for non-*accessible* toilet stalls are included to ensure that persons who do not use wheelchairs or scooters can be adequately accommodated within any toilet stall. Universal features include *accessible* hardware and minimum a stall width

to accommodate persons of large stature.

A different coloured door on the accessible stall can be used to identify uniqueness without labeling disability.

APPLICATION

If toilet stalls are provided in a toilet or bathing *facility*, then the number of *accessible* toilet stalls designated to accommodate persons with *disabilities* shall comply with Table 3.3.2.1.

Accessible toilet stalls shall comply with this section.

All other toilet stalls within a facility (i.e., those considered to be non-*accessible*) shall be minimum 920 mm (36 in.) wide by 1525 mm (60 in.) long, and shall incorporate door-locking mechanisms in compliance with this section.

DESIGN REQUIREMENTS

Accessible toilet stalls shall

- be on an *accessible route* complying with Section 1.1.3 Accessible Routes, Paths

and Corridors;

- have internal dimensions at least 1830 x 1830 mm (72 in. x 72 in.). In a *retrofit* situation where providing the required internal dimensions is *technically not feasible*, the internal dimensions may be reduced to 1525 mm x 1525 mm (60 in. x 60 in.);
- have a toilet complying with Section 3.3.3 Toilets; and
- be equipped with a collapsible coat hook mounted not more than 1200 mm (47 in.) from the floor on a side wall and projecting not more than 50 mm (2 in.) from the wall.

Toilet stall doors shall

- be capable of being locked from the inside by a device that is operable with one hand; does not require fine finger control, tight grasping, pinching, or twisting of the wrist; requires a force of not more than 22 N (4.9 lb.) to activate (e.g., sliding bolt or lever); and can be opened from the outside in an emergency situation by an authorized person.
- provide a *clear* opening of

# of toilet stalls within the washroom	Required # of <i>accessible</i> toilet stalls
1-5	1
More than 5	2

Table 3.3.2.1 Number of Accessible Toilet Stalls

3.3.2 Toilet Stalls (continued)

at least 900 mm (35 in.) with the door in the open position. In a *retrofit* situation where it is *technically not feasible* to provide the required *clear* opening, the *clear* opening may be reduced to 810 mm (32 in.);

- swing outward, unless additional *clear space* of at least 760 mm x 1370 mm (30 in. x 54 in.) is provided within the stall, out with the arc of the door swing;
- be aligned with the *clear space* adjacent to the toilet fixture;
- be equipped with gravity hinges so that the door closes automatically;
- be provided with a “D”-type *colour contrasting* door pull, at least 140 mm (5-1/2 in.) long, on the inside of an out-swinging door, located so that the centre line is between 200 and 300 mm (7-7/8 in. and 11-3/4 in.) from the hinged side of the door, located 900 mm (35-1/2 in.) above the finished floor; and
- be provided with a “D”-type *colour contrasting* door pull at least 140 mm (5-1/2 in.) long, on both sides of the door, located near the latch, 900 mm (35-1/2 in.) above the finished floor.

Where more than one *accessible* toilet stall is provided within a washroom, at least one *accessible* stall shall be configured to provide the required *transfer space* on the left side of the toilet fixture, and at

least one *accessible* stall shall be configured to provide the required *transfer space* on the right side of the toilet fixture.

The *transfer space* adjacent to the toilet fixture, as required by Section 3.3.3 Toilets, shall be *clear* of obstructions (such as garbage bins or baby change tables).

Toilet stall doors shall be *colour contrasted* with the toilet partitions.

RELATED SECTIONS

- 1.1.1 Space and Reach Requirements
- 1.1.2 Protruding and Overhead Objects
- 1.2.1 Texture, Finishes and Colour
- 3.1.3 Doors
- 3.3.3 Toilets
- 3.3.6 Washroom Accessories
- 3.3.8 Grab Bars
- 3.5.1 Controls and Operating Mechanisms
- 3.5.3 Interior Lighting

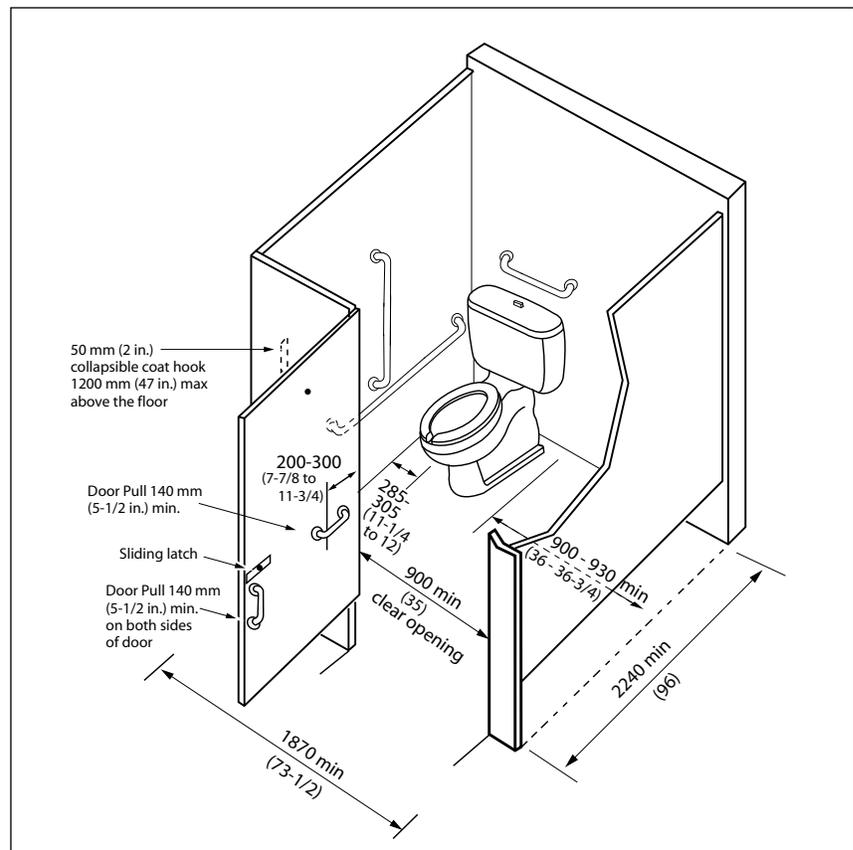

Figure 3.3.2.1 Accessible Toilet Stall

3.3 WASHROOM FACILITIES

INTERIOR STANDARDS

3.3.3 Toilets

RATIONALE

Automatic flush controls are preferred. If flushing mechanisms are not automated, then consideration must be given to the ability to reach a switch and the hand strength or dexterity to operate it. Lever style handles on the transfer side of the toilet facilitate this. Appropriate placement of grab bars makes sitting and standing or transfers between toilet and wheelchair safer.

APPLICATION

Accessible toilets shall comply with this section.

DESIGN REQUIREMENTS

Toilet fixtures shall have

- the top of the seat between 400 mm and 460 mm (15-3/4 in. and 18-1/8 in.) from the floor;
- no spring-activated seat;
- a back support where there is no seat lid or tank; and
- the tank top securely attached with a tamper proof bolt.

Toilets shall be located so that the clearance between the fixture and the wall on one side is 285 mm - 305 mm (11-1/4 in. - 12 in.). A minimum 920 mm (36 in.) - wide transfer *space* shall be provided on the other side of the toilet fixture. In a *retrofit* situation where it is *technically not feasible* to provide a 920 mm (36 in.)- wide transfer *space*, the *space* may be reduced to 760 mm (30 in.).

The transfer *space* shall be clear of obstructions (such as garbage bins or baby change tables).

Toilet flush controls shall either

- be electronically automatically controlled;
- be hand-operated on the transfer side of the toilet in compliance with Section 3.2.2 Tables, Counters and Work Surfaces; or
- include an assistive flushing mechanism or lever if dual flush.

Toilets shall be equipped with grab bars that

- comply with Section 3.3.8 Grab Bars;
- are mounted horizontally on the side wall closest to the toilet fixture, extending not less than 450 mm (17-3/4 in.) in both directions from the most forward point of the toilet fixture, 840 mm - 920 mm (33 in. - 36 in.) above the floor;
- are at least 760 mm (30 in.) long, mounted vertically on the side wall closest to the toilet fixture, 150 mm (5-7/8 in.) in front of the most forward point of the toilet fixture, with its lowest edge no closer than 60 mm (2-3/8 in.) above the horizontal bar; and
- are at least 600 mm (23-5/8 in.) in length, mounted horizontally on the wall behind the toilet fixture, centred on the toilet bowl, 840 mm - 920 mm (33 in. - 36 in.) above the

floor.

When a toilet-paper dispenser is provided, the dispenser shall

- be wall mounted;
- be located below the grab bar, with its highest surface no closer than 60 mm (2-3/8 in.) from the horizontal bar;
- dispense paper 0 - 300 mm (0 - 11-3/4 in.) in front of the toilet seat and not less than 600 mm (23-5/8 in.) above the floor; and
- be contrasting in colour to the wall.

RELATED SECTIONS

- 1.1.1 Space and Reach Requirements
- 1.2.1 Texture, Finishes and Colour
- 3.3.2 Toilet Stalls
- 3.3.8 Grab Bars
- 3.5.1 Controls and Operating Mechanisms
- 3.5.3 Interior Lighting

3.3 WASHROOM FACILITIES

3.3.3 Toilets (continued)

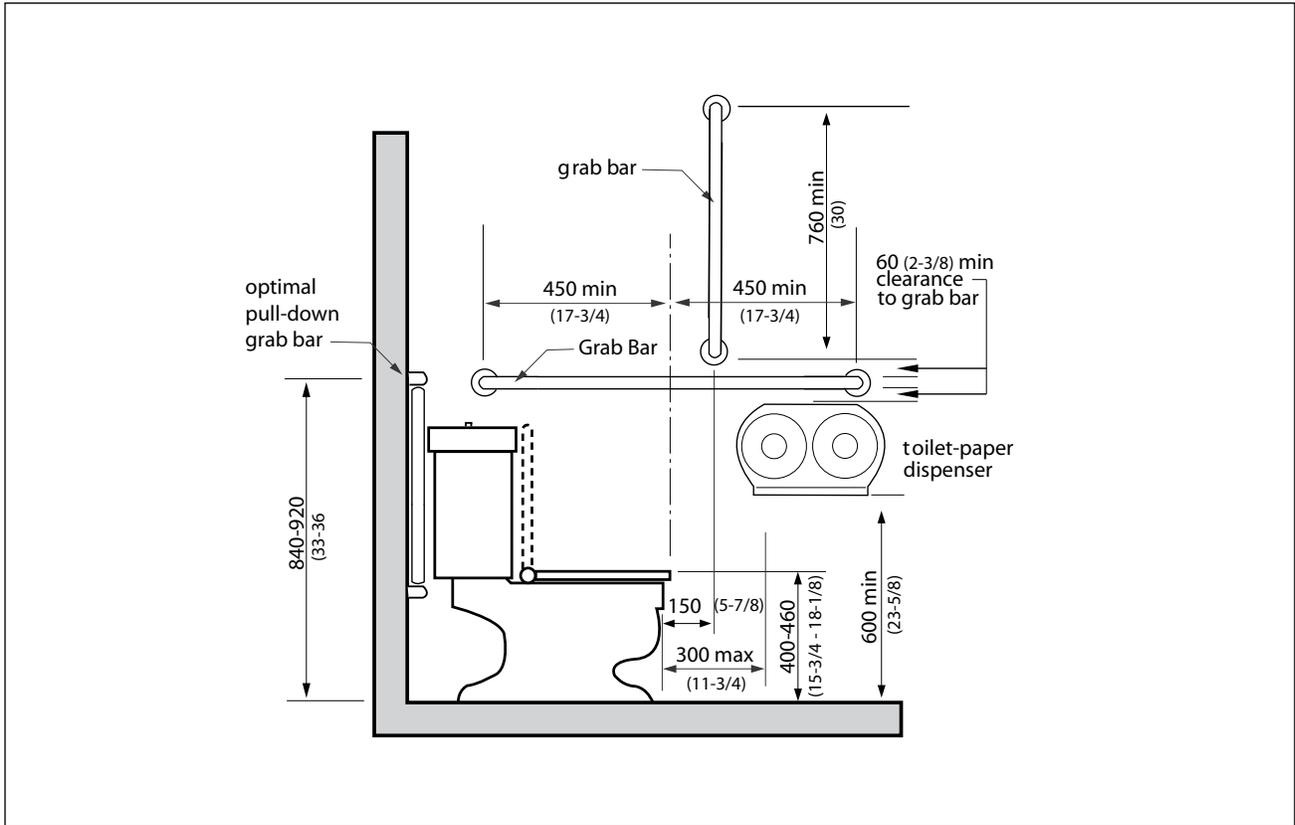

Figure 3.3.3.1 Grab Bar Configuration

3.3 WASHROOM FACILITIES

3.3.4 Lavatories

RATIONALE

The accessibility of lavatories will be greatly influenced by their operating mechanisms. Use of faucets incorporating infrared technology are preferred. For an individual in a wheelchair, a lower counter height and clearance for knees under the counter is required. This lower counter may also serve children.

APPLICATION

All lavatories shall comply with this section. In a *retrofit* situation where it is *technically not feasible* to have all lavatories comply with this section, at least one lavatory in each *accessible* washroom shall comply.

DESIGN REQUIREMENTS

Lavatories shall

- be on an *accessible route* complying with Section 1.1.3 Accessible Routes, Paths and Corridors;
- be mounted so that the minimum distance between the centre line of the fixture and the side wall is 460 mm (18-1/8 in.);
- have the top located no more than 865 mm (34 in.) from the floor;
- have a knee *space* of at least 760 mm (30 in.) wide;
 - and 735 mm (29 in.) high at the front edge;
 - 685 mm high (27 in.) at a point 205 mm (8-1/8 in.) back from the front edge;

- and
 - 230 mm (9 in.) high over the distance from a point 280 mm (11 in.) to a point 430 mm (16-7/8 in.) back from the front edge;
- have a minimum *clear space* 760 mm wide (30 in.) and 1370 mm (54 in.) deep, of which a maximum of 480 mm (18-7/8 in.) in depth may be under the lavatory;
- have hot water and drain pipes insulated if they abut the clearances noted above, or have the water temperature limited to a maximum of 43 degrees Celsius (100 degrees F); and
- have soap and towel dispensers that are activated and dispensed using one hand;
- be located within 500 mm (19-5/8 in.) reach of a seated person;
- be located so that the dispensing height is not more than 1200 mm (47 in.) above the floor;
- be *colour contrasted* from the surrounding environment; and;
- be in compliance with Section 3.5.1 Controls and Operating Mechanisms.

Faucets and other controls shall

- be in compliance with Section 3.5.1 Controls and Operating Mechanisms; and
- be located so that the distance from the centre line of the faucet to the edge of the basin, or where the basin

is mounted in a vanity, to the front edge of the vanity is not more than 485 mm (19-1/8 in.).

The front apron of a vanity shall have a minimum clearance of 760 mm (30 in.) wide by 735 mm (29 in.) high.

Shelves or other projections above lavatories shall be located so they will not present a hazard to individuals with vision *impairments*.

There shall be no abrasive surfaces below the vanity.

Where pipes are exposed beneath a sink or vanity they shall be insulated to protect individuals using a wheelchair whose legs may come into contact with hot water pipes.

Where mirrors are provided at lavatories or vanity units, they shall comply with Section 3.3.6 Washroom Accessories.

RELATED SECTIONS

- 1.1.1 Space and Reach Requirements
- 1.2.1 Texture, Finishes and Colour
- 3.5.1 Controls and Operating Mechanisms
- 3.5.3 Interior Lighting

3.3.4 Lavatories (continued)

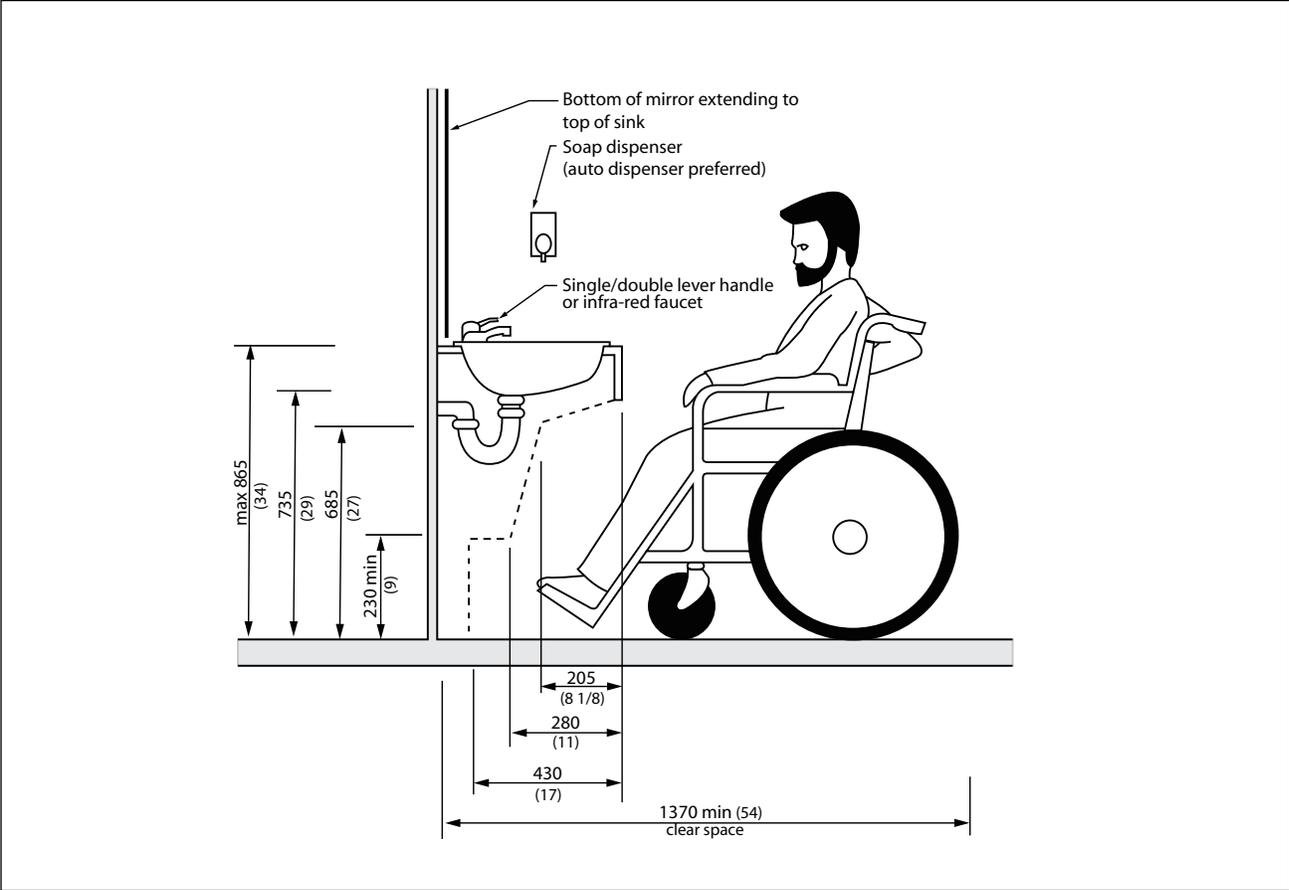

Figure 3.3.4.1 Lavatory Criteria

3.3 WASHROOM FACILITIES

3.3.5 Urinals

RATIONALE

A *clear space* is required in front of urinals to maneuver a mobility device. The provision of grab bars may assist an individual rising from the chair and steady-ing themselves. Floor-mounted urinals accommodate children and persons of short stature as well as making it easier to drain personal care devices. Flush controls should be lever or automatic (preferred). Strong *colour contrast* will assist individuals with vision impairments.

APPLICATION

Where urinals are provided in an *accessible* toilet or bathing *facility*, at least one shall comply with this section.

DESIGN REQUIREMENTS

Urinals shall be

- wall-mounted with the rim located between 488 mm - 512 mm (19-1/4 in. - 20-1/8 in.) from the finished floor; or
- floor-mounted, with the rim level at the finished floor.

A *clear space* of 760 mm x 1370 mm (30 in. x 54 in.) shall be provided in front of the urinal to allow for a forward approach. This *clear space* shall adjoin or overlap an *accessible route* and shall comply with Section 1.1.1 Space and Reach Requirements.

The urinal shall have grab bars installed on each side that

- are vertically mounted
- are not less than 600 mm (23-5/8 in.) long
- have their lower end located 600 mm - 650 mm (23-5/8 in. - 25-1/2 in.) above the floor
- are located not more than 380 mm (15 in.) from the centre line of the urinal; and
- comply with Section 3.3.8 Grab Bars..

Where privacy screens are provided

- there shall be at least 920 mm (36 in.) of clearance between them; and
- they shall incorporate a pronounced *colour contrast* to
- differentiate them from the surrounding environment,

with a vertical outer edge that *colour contrasts* with the screen and the surrounding environment.

Flush controls shall be auto flusher controlled or hand-operated at no more than 1120 mm (44 in.) above the finished floor, and shall comply with Section 3.5.1 Controls and Operating Mechanisms.

Where a washroom contains more than three urinals, one urinal shall be

- installed with the rim no higher than 335 mm (14 in.) from the finished floor: or
- floor-mounted, with the rim level at the finished floor.

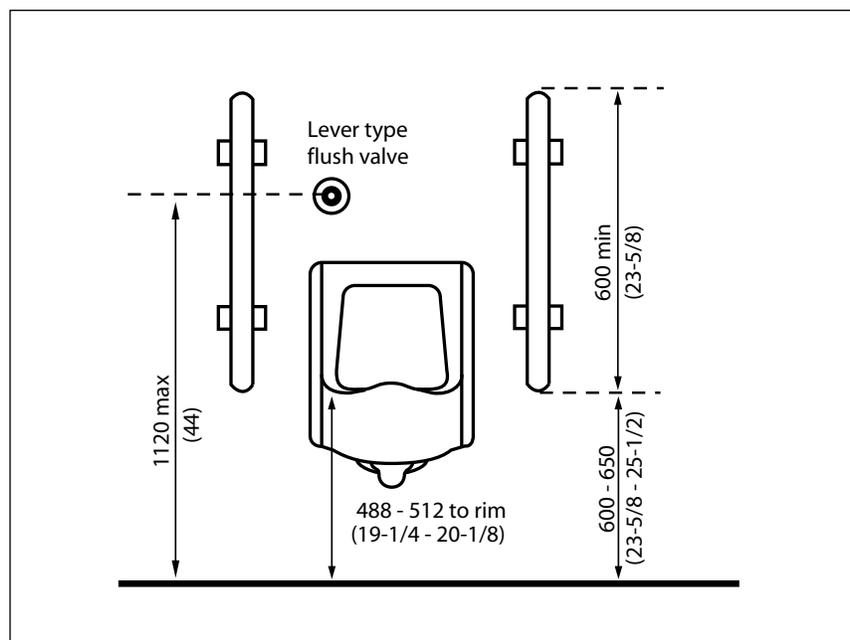

Figure 3.3.5.1 Front Approach to Urinal

3.3.5 Urinals (continued)

RELATED SECTIONS

- 1.1.1 Space and Reach Requirements
- 1.2.1 Texture, Finishes and Colour
- 3.5.1 Controls and Operating Mechanisms
- 3.5.3 Interior Lighting

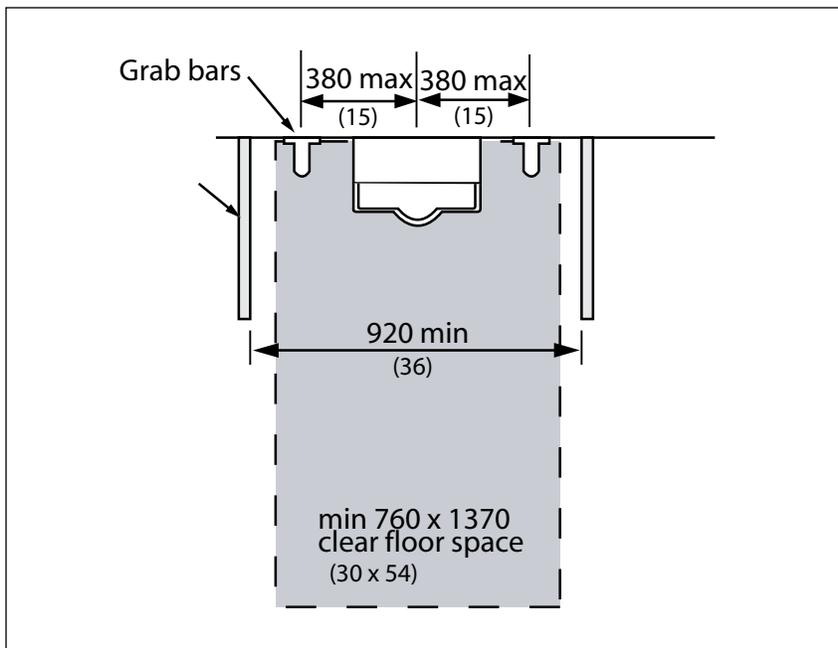

Figure 3.3.5.1 Approach of Urinal

3.3 WASHROOM FACILITIES

3.3.6 Washroom Accessories

RATIONALE

Washroom accessories and mechanisms often require hand strength and dexterity to operate. As a result, automatic activation dispensers are preferred.

Accessories that require the use of two hands to operate can present difficulties for a range of persons with *disabilities* when the ability to reach or balance is impaired. Refer to Section 3.5.1 Controls and Operating Mechanisms for greater detail.

APPLICATION

Where washroom accessories are provided in a toilet or bathing *facility*, they shall comply with this section. In a *retrofit* situation where it is *technically not feasible*

to make all washroom accessories comply with this section, at least one of each type of washroom accessory shall comply in all *accessible* toilet or bathing *facilities*.

DESIGN REQUIREMENTS

Automatic hands-free designs are preferred.

Each type of washroom accessory provided, except those located in toilet stalls as specified in Section 3.3.2 Toilet Stalls and in lavatories as specified in Section 3.3.4 Lavatories, shall have *operable portions* and controls mounted between 900 mm (35 in.) and 1200 mm (47 in.) from the floor.

Accessories mounted over a

counter shall not require a forward reach of more than 600 mm (23-5/8 in.).

The operable controls and mechanisms of washroom accessories shall comply with Section 3.5.1 Controls and Operating Mechanisms.

Where mirrors are provided, at least one shall be mounted with its bottom edge not more than 1000 mm (39-3/8 in.) from the floor.

A separate full-length mirror shall be provided elsewhere in the washroom that

- incorporates a *clear* floor area in front, at least 760 mm (30 in.) wide x 1370 mm (54 in.) deep;

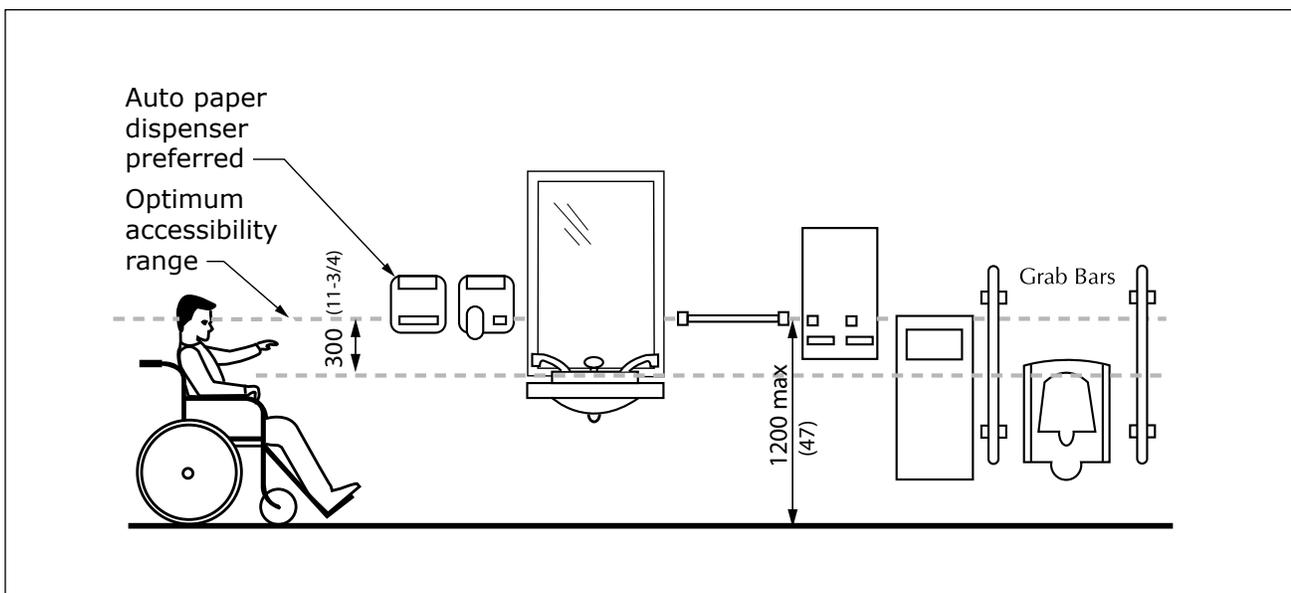

Figure 3.3.6.1 Washroom Accessories

3.3.6 Washroom Accessories (continued)

- is mounted with its lower edge 460-600 mm (18 - 23-1/2 in.) above the floor; and
- extends to at least 1830 mm (72 in.) above the floor.

RELATED SECTIONS

- 1.1.1 Space and Reach Requirements
- 1.1.2 Protruding and Overhead Objects
- 1.2.1 Texture, Finishes and Colour
- 3.5.1 Controls and Operating Mechanisms
- 3.5.3 Interior Lighting

INTERIOR STANDARDS

3.3.7 Individual Washrooms

RATIONALE

The provision of a separate individual washroom is advantageous in a number of instances. For an individual using a wheelchair, the extra *space* provided with a separate washroom is preferred to an accessible stall. Should an individual require an attendant to assist them in the washroom then the complication of a woman entering a men's washroom or vice versa is avoided. This same scenario would apply to a parent with a young child of a different gender. In the event of an accident or fall by a single individual in this form of washroom, an emergency call switch and a means of unlocking the door from the outside are important safety features. A fold down adult change platform or a height adjustable change table is optional.

APPLICATION

Individual washrooms shall be provided as required by Section 3.3.1 Toilet and Bathing Facilities.

Accessible individual washrooms shall comply with this section.

DESIGN REQUIREMENTS

Accessible individual washrooms shall be on an *accessible route* complying with Section 1.1.3 Accessible Routes, Paths and Corridors.

Accessible individual washrooms shall be identified with *signage* complying with applicable provisions

of Section 1.2.4 Signage.

Infant change stations in individual washrooms shall comply with the requirements as outlined in Section 3.3.1 Toilet and Bathing Facilities.

Individual washrooms shall

- be designed to permit a wheelchair to turn within a *clear space* that has a diameter of not less than 2440 mm (96 in.);
- be equipped with a door that
- complies with Section 3.1.3 Doors;
- is capable of being locked from the inside with one hand and being released from the outside in case of emergency by authorized personnel;
- has graspable latch operating and locking mechanisms located not less than 900 mm (35 in.) and not more than 1000 mm (39-3/8 in.) above the floor; and
- where the door is out-swinging, has a minimum 140 mm (5-1/2 in.) long D-shaped handle mounted either horizontally or vertically on the inside, located 100 mm (4 in.) from the hinge edge of the door and 900 mm (35-1/2 in.) from the floor.
- be provided with a lavatory conforming to Section 3.3.4 Lavatories;
- be equipped with a toilet conforming to Section 3.3.3 Toilets, and be located;
 - so that its centre line is not less than 460 mm (18-1/8 in.) and not more

than 480 mm (18-7/8 in.) from an adjacent wall on one side; and

- so that its centre line is not less than 1060 mm (42 in.) to any wall, fixture or other obstruction on the other side;
- be equipped with grab bars conforming to Section 3.3.8 Grab Bars;
- have fixture clearances conforming to Sections 3.3.3 Toilets and 3.3.4 Lavatories;
- be designed to permit a wheelchair to back into the required *clear space* beside the toilet fixture;
- be equipped with a collapsible coat hook mounted not more than 1200 mm (47 in.) from the floor on a side wall and projecting not more than 50 mm (2 in.) from the wall; and
 - a mirror and washroom accessories complying with Section 3.3.6 Washroom Accessories;
- Optional: be equipped with a fold-down grab bar at least 760 mm (30 in.) in length at the open side of the toilet, mounted 420 - 440 mm (16-1/2 - 17-3/8 in.) from the centre line of the toilet and 630 - 690 mm (24-3/4 - 27-1/8 in.) above the floor.

Where *accessible* individual washrooms are provided in assembly *buildings*, such as recreation centres, the washroom shall incorporate an emergency call system linked to a light outside the door.

3.3 WASHROOM FACILITIES

3.3.7 Individual Washrooms (continued)

Accessible individual washrooms in assembly *buildings* shall incorporate a change bench;

- that is at least 760 mm (30 in.) wide by 1830 (72 in.) long;
- located with the change surface no higher than 865 mm (34 in.);
- which incorporates an adjacent *clear space* not less than 760 mm (30 in.) by 1370 mm (54 in.);
- designed to support 2.66 kN (600 pounds);
- located on an *accessible route* in compliance with Section 1.1.3 Accessible Routes, Paths and Corridors;
- that is spring operated for ease of folding up against the wall; and
- if of the fold-down type, have no *operable portions* higher than 1200 mm (47 in.).

- 3.5.4 Interior Glare and Light Sources
- 3.5.3 Interior Lighting

RELATED SECTIONS

- 1.1.1 Space and Reach Requirements
- 1.1.2 Protruding and Overhead Objects
- 1.2.4 Signage
- 3.1.3 Doors
- 3.2.6 Specialty Change Rooms
- 3.3.3 Toilets
- 3.3.4 Lavatories
- 3.3.5 Urinals
- 3.3.6 Washroom Accessories
- 3.3.8 Grab Bars
- 3.3.9 Shower Stalls
- 3.4.1 Visual Alarms
- 3.5.1 Controls and Operating Mechanisms
- 3.5.2 Card Access, Safety and

3.3 WASHROOM FACILITIES

3.3.7 Individual Washrooms (continued)

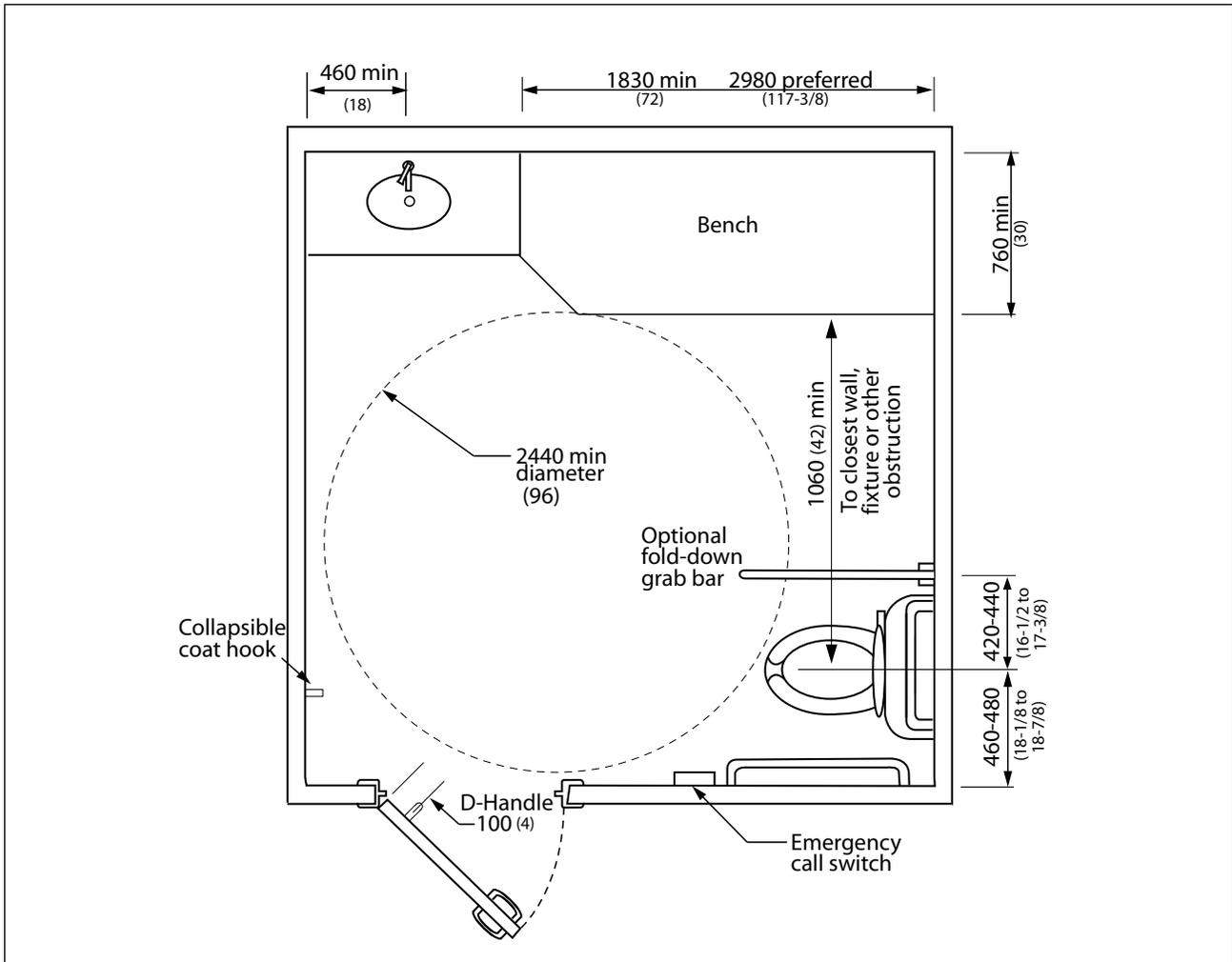

Figure 3.3.7.1 Individual Washroom

3.3.8 Grab Bars

RATIONALE

Grab bars are an important feature to those who require assistance in standing up, sitting down or stability while standing. Transferring between toilet and wheelchair may be another scenario where grab bars are utilized.

APPLICATION

Grab bars shall comply with this section.

DESIGN REQUIREMENTS

Grab bars shall

- be installed to resist a load of at least 2.00 kN (450 lb.), applied vertically or horizontally;
- be not less than 30 mm (1-3/16 in.) and not more than 43 mm (1 5/8 in.) in diameter;
- have a clearance of 51 mm (2 in.) from the wall;
- be free of any sharp or abrasive *elements*;
- be *colour contrasted* with the surrounding environment; and
- have a slip-resistant surface.

Adjacent surfaces shall be free of any sharp or abrasive *elements*.

RELATED SECTIONS

- 1.1.1 Space and Reach Requirements
- 1.2.1 Texture, Finishes and Colour
- 3.3.3 Toilets
- 3.3.5 Urinals
- 3.3.7 Individual Washrooms
- 3.3.9 Shower Stalls
- 3.5.3 Interior Lighting

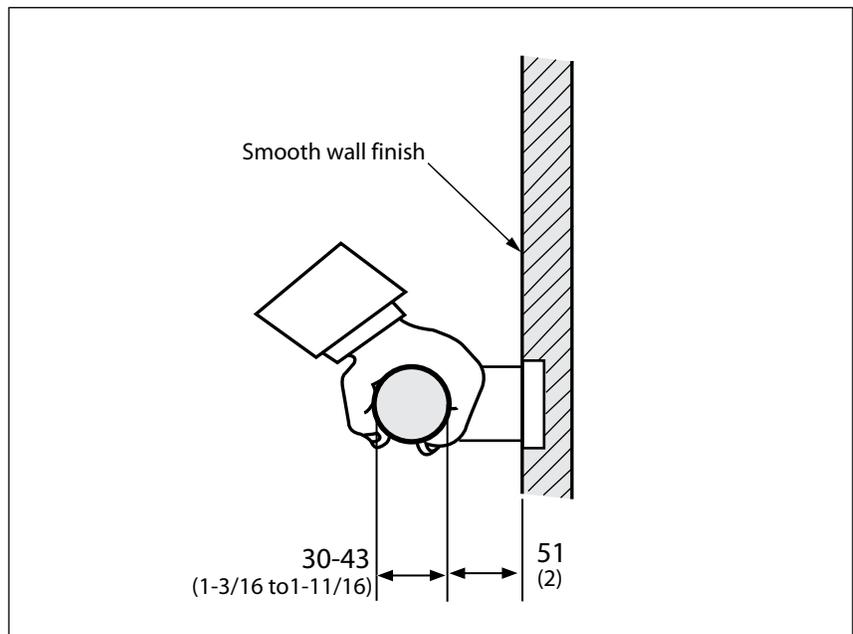

Figure 3.3.8.1 Grab Bars

INTERIOR STANDARDS

3.3.9 Shower Stalls

RATIONALE

Grab bars and nonslip materials are safety measures which will assist everyone. Additional equipment, such as a hand-held shower or bench, may be an asset to someone with a *disability*. Equipment that *colour contrasts* from the shower stall itself assists individuals with vision *impairments*. Roll-in or curbless shower stalls eliminate the hazard of stepping over a threshold and are essential for persons with *disabilities* who use wheelchairs in the shower. At least one shower chair as an accessory piece of equipment is required for wheel-in shower users.

APPLICATION

Where shower stalls are provided, 50% of shower stalls shall comply with this section. In a *retrofit* situation where it is *technically not feasible* to have 50% of shower stalls comply with this section, at least 10%, but never less than one, in each bathing area shall comply with this section.

DESIGN REQUIREMENTS

Accessible shower stalls shall

- be on an *accessible route* complying with Section 1.1.3 Accessible Routes, Paths and Corridors;
- be at least 1525 mm (60 in.) in width and 920 mm (36 in.) in depth;
- have a *clear space* at the *entrance* to the shower of at

least 920 mm (36 in.) in depth and the same width as the shower, except that fixtures are permitted to project into that *space*, provided they do not restrict access to the shower;

- have a slip-resistant floor surface;
- have no threshold, or a beveled threshold not exceeding 6 mm (1/4 in.) above the finished floor;
- be equipped with a wall-mounted folding seat that is not spring-loaded, or make provisions for a portable seat that is
 - 450 mm (17-3/4 in.) wide and 400 mm (15 in.) deep;
 - mounted approximately 450 mm (17-3/4 in.) above the floor;
 - *colour contrasted* with the background; and
 - designed to carry a minimum load of 2.70 kN (600 lbs.);
- be equipped with an L-shaped grab bar that;
 - has a horizontal component of at least 920 mm (36 in.), mounted horizontally approximately 700 - 800 mm (27-1/2 - 31-1/2 in.) above the floor, located on the wall so at least 300 mm (11-3/4 in.) of its length is reachable from one side of the seat;
 - has a vertical component of at least 760 mm (30 in.), located at the opposite end to the seat; and
 - conforms to Section 3.3.8 Grab Bars;

- be equipped with a vertical grab bar that shall
 - be at least 760 mm (30 in.) in length;
 - be mounted 80 - 120 mm (3-1/8 - 4-3/4 in.) from the front edge, starting between 700 and 800 mm (27-1/2 and 31-1/2 in.) from the floor; and
 - conforms to Section 3.3.8 Grab Bars;
- be equipped with an individually controlable pressure equalizing or thermostatic mixing valve in compliance with Section 3.2.1 Information, Reception and Service Counters, delivering water at a temperature no greater than 49 degree Celsius (120 degree Fahrenheit);
- have the shower control/mixing valve located above the grab bar but no higher than 1000 mm (39-3/8 in.), maximum 685 mm (27 in.) from the seat wall;
- be equipped with a shower head with at least 1525 mm (60 in.) of flexible hose that can be used both as a fixed position shower head and as a hand held shower head. The shower spray unit shall be reachable from the seated positions and have an on/off control.
- EXCEPTION: The use of two fixed height shower heads with the capability of adjusting the direction of water flow is permitted instead of a hand-held spray unit in *facilities* that may be

3.3 WASHROOM FACILITIES

3.3.9 Shower Stalls (continued)

subject to vandalism. The height of the higher shower head to be 1825 mm (72 in.). The height of the lower shower head to be 1400 mm (55-1/8 in.). A valve to direct water between the shower heads, in compliance with 3.5.1, to be located adjacent to the shower control/mixing valve; and

- have soap holder(s) which can be reached from the

seated position, ideally fully recessed.

Where the shower head is mounted on a vertical bar, the bar shall be installed so as not to obstruct the use of the grab bar. Floor drains to be level with the finished floor, located below the seat, off to one side or off to one end.

Enclosures for shower stalls shall

not obstruct controls or obstruct transfer from wheelchairs onto shower seats

RELATED SECTIONS

- 1.2.1 Texture, Finishes and Colour
- 3.2.6 Specialty Change Rooms
- 3.3.8 Grab Bars
- 3.5.1 Controls and Operating Mechanisms
- 3.5.3 Interior Lighting

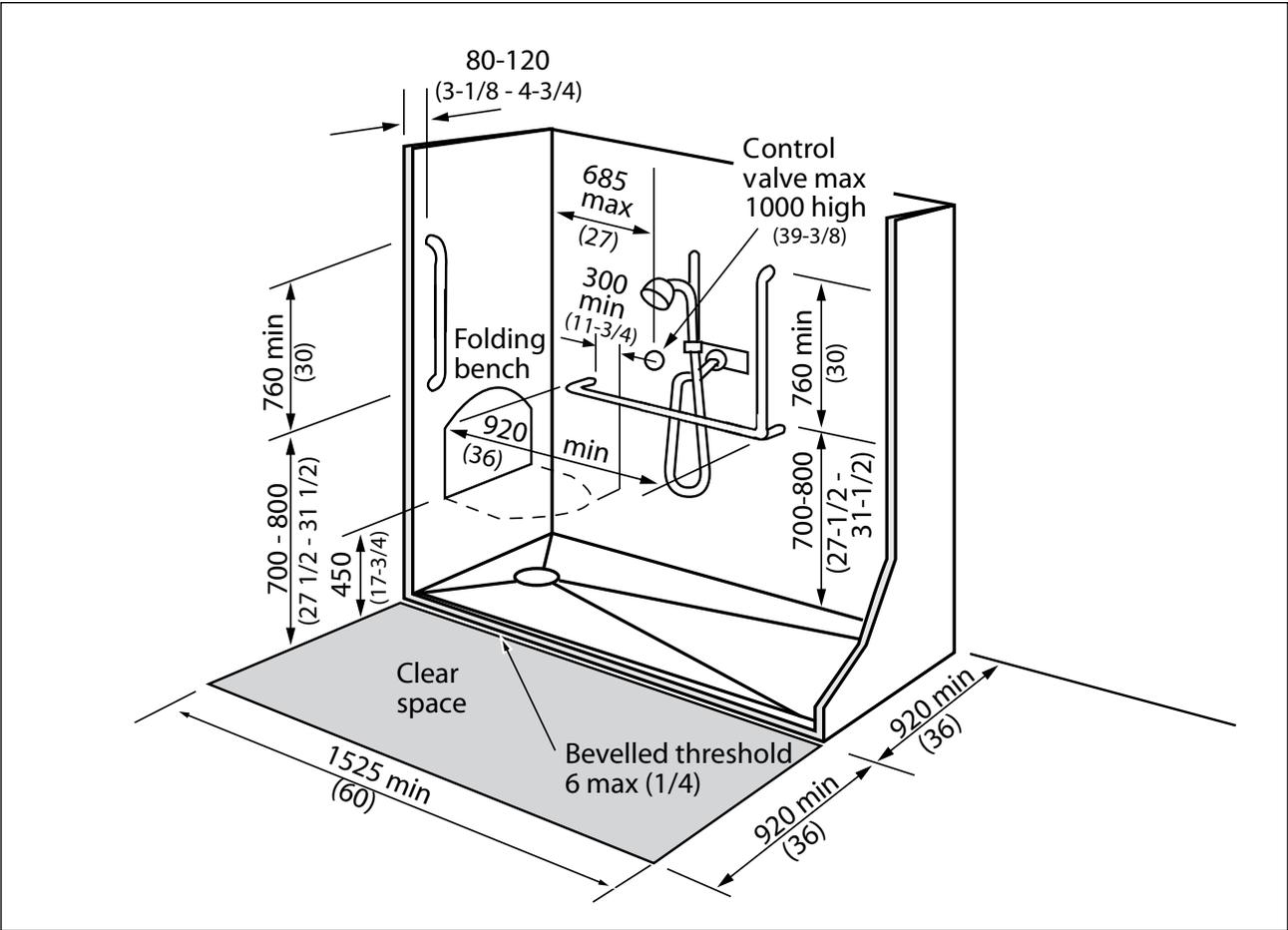

Figure 3.3.9.1 Shower Stall

INTERIOR STANDARDS

3.4.1 Visual Alarms

RATIONALE

Visual alarms are essential safety features for individuals who are deaf, deafened or hard of hearing such that they would not hear an audible alarm.

APPLICATION

Visual alarms shall comply with this section.

At a minimum, visual alarm appliances shall be provided in *facilities* in each of the following areas: rest rooms and any other general usage areas (e.g., *meeting rooms*), hallways, lobbies and any other areas for *common use*.

Visual alarm signal appliances shall be integrated into the *facility* alarm system. If single-station audible alarms are provided, then single-station visual alarms shall be provided.

In a *retrofit* situation where an alarm system is being upgraded, the alarm system shall include visual alarm signals.

DESIGN REQUIREMENTS

Visual alarm signals shall have the following minimum photometric and location features:

- the lamp shall be a Xenon strobe type or equivalent;
- the colour shall be *clear* or nominal white (i.e. unfiltered or *clear* filtered white light);
- the maximum pulse duration shall be two-tenths of one

second (0.2 sec) with a maximum duty cycle of 40 percent. The pulse duration is defined as the time interval between initial and final points of 10% of maximum signal;

- the intensity shall be a minimum of 75 candela;
- the flash rate shall be a minimum of 1 Hz and a maximum of 3 Hz;
- the appliance shall be placed 2100 mm (82-3/4 in.) above the highest floor level within the *space* or 150 mm (5-7/8 in.) below the ceiling, whichever is lower;
- in general, no place in any room or *space* required to have a visual signal appliance, shall be more than 15 meters (50 ft.) from the signal (in the horizontal plane). In large rooms and *spaces* exceeding 30 meters (100 ft.) across, without obstructions 2000 mm (78-3/4 in.) above the finished floor, such as auditoriums, devices may be placed around the perimeter, spaced a maximum of 30 meters (100 ft.) apart, in lieu of suspending appliances from the ceiling;
- no place in common corridors or hallways in which visual alarm signalling appliances are required shall be more than 15 meters (50 ft.) from the signal; and
- the alarms shall be synchronized to flash in unison.

RELATED SECTIONS

- 3.1.8 Emergency Exits, Fire Evacuation and Areas of Rescue Assistance

3.4.2 Assistive Listening Systems

RATIONALE

The provision of *assistive listening devices* is important for the range of individuals who may have difficulty hearing.

Adequate and controllable lighting is required for persons who lip-read, or those who require increased task lighting, due to vision *impairment*.

APPLICATION

Assistive listening systems shall comply with this section.

Assembly areas greater than 100 sq.m. (1080 sq.ft.) in area, where audible communications are integral to the use of the *space* (e.g., concert theatres, *meeting rooms*, classrooms, auditoria, etc.), shall be equipped with an assistive listening system encompassing the entire area. Exception: Only half the seating area need be encompassed if an induction loop system is used.

For other *assembly areas*, a permanently installed listening system shall be provided. In a smaller meeting spaces, supplementary wiring and electrical outlets necessary to support a portable listening system shall be provided. A portable listening device must be made available upon request.

The minimum number of receivers to be provided shall be equal to 4% of the total number of seats, but no less than two.

DESIGN REQUIREMENTS

Signage complying with applicable provisions of Section 1.2.4 Signage and shall be installed to notify patrons of the availability of a listening system.

Induction loops, infrared systems and FM radio frequency systems shall be considered acceptable types of *assistive listening systems* for persons who are hard of hearing.

Where an induction loop system is installed, dimmer switches and other controls that incorporate transformer coils shall be located so as not to interfere with the audio induction loop.

Where infrared *assistive listening devices* are used, overhead lights shall be located so as not to cancel out the infrared signal at the receiver.

Where an FM loop system or other *assistive listening devices* are available in public *facilities* or meeting areas, portable headsets that are compatible with personal hearing aids shall be made available.

Where an induction loop system is utilized, at least half the seating area shall be encompassed.

Where the listening system provided serves individual fixed seats, such seats shall be located within a 15-meter (50-ft.) viewing distance of the stage or playing area and shall have a complete

view of the stage or playing area.

Background noise from mechanical systems shall be minimized.

Areas used for presentations and other public events, where listening to verbal communication is integral to the function of the *space*, shall incorporate one well-illuminated area for sign-language interpreting. Lighting control systems must allow the area to be independently controlled.

RELATED SECTIONS

- 1.2.2 Acoustics
- 1.2.4 Signage
- 3.5.3 Interior Lighting

3.5.1 Controls and Operating Mechanisms

RATIONALE

Operating mechanisms that require a high degree of dexterity or strength will be difficult for many people to use. They can also be obstacles for children, individuals with arthritis or even someone wearing gloves. Controls that require two hands to operate can also be difficult for some people, particularly those with reach or balance limitations, or those who must use their hands to hold canes or crutches.

The placement of controls is integral to their accessibility. For the individual using a wheelchair, the height of the controls and the *space* to position the wheelchair in front of the controls are important. Controls placed high on a wall are also difficult for children or persons of short stature.

Individuals with vision *impairments* may have difficulty with flush-mounted buttons, touch screens or controls without *tactile* markings. Controls that contrast in colour from their background, including *colour contrasted* raised letters, may be easier to locate. Persons with cognitive challenges may find counter-intuitive controls or graphics difficult.

APPLICATION

Controls and operating mechanisms generally used by staff or public (e.g., light switches and dispenser controls) shall comply with this section. Exception: Restricted-access controls.

DESIGN REQUIREMENTS

A *clear*, level floor area at least 900 mm x 1500 mm (35-1/2 in. x 59 in.) shall be provided at controls and operating mechanisms, such as dispensers and receptacles.

The *operable portions* of controls and operating mechanisms such as electrical switches, thermostats and intercom switches, shall be located between 900 mm (35 in.) and 1200 mm (47 in.) from the floor. Exception: Elevators and power door operator controls. Refer to Sections 3.1.3 Doors and 3.1.5 Elevators.

Controls or operating mechanisms shall

- be located no closer than 700 mm (27-1/2 in.) from an inside corner, for side-access;
- be located no closer than 400 mm (15-3/4 in.) from an inside corner, for front-access.

Electrical outlets and other types of devices shall be located no lower than 400 mm (15-3/4 in.)

Faucets and other controls shall be hand-operated or electronically controlled.

Hand-operated controls and mechanisms shall be operable

- with one hand, without tight grasping, pinching, or twisting of the wrist; and
- with a force of less than 13N (3 lbf.).

- Control settings shall provide *tactile* and/or auditory information, indicating function and position of controls.

Information on visual displays shall

- be supplemented by *tactile* and/or auditory information;
- be *colour contrasted*; and
- be located on a glare-free surface.

Operating mechanisms shall be capable of being illuminated to at least a level of 100 lux (9.2 ft-candles).

Colour contrast shall be incorporated into controls and operating mechanisms to differentiate them from the surrounding environment.

Dispensers with visual markings shall also incorporate *tactile* lettering and pictograms.

RELATED SECTIONS

All relevant parts of Sections 1.0 General Design Standards, 2.0 Exterior Design Standards and 3.0 Interior Design Standards.

3.5.1 Controls and Operating Mechanisms (continued)

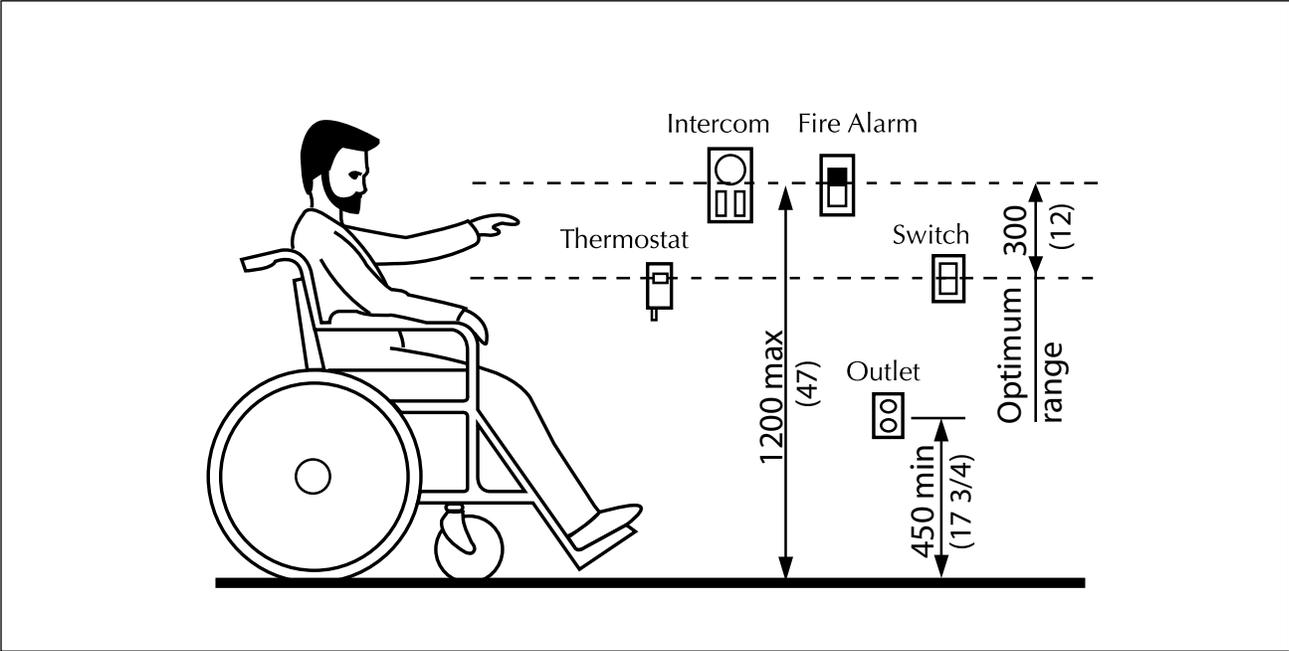

Figure 3.5.1.1 Reach Range for Accessible Controls

3.5.2 Card Access, Safety and Security Systems

RATIONALE

In many cases, persons such as seniors and persons with *disabilities* may be considered to have a higher degree of vulnerability and therefore seek more reassurance and inherent security. Items such as adequate lighting and *accessible* signalling devices promote this security. Emergency signalling devices are important in individual washrooms where the potential for a fall is increased and an individual may be alone.

Where card-access systems are selected as a means of entry to particular *facilities* or *spaces*, the systems and components selected should be suitable for use by persons with varying abilities, including persons with reduced manual dexterity, poor vision or difficulty with reaching. The use of heat-sensing activation buttons should be avoided, as they are indiscernible to a person who is blind. Proximity scanning card systems are preferred.

APPLICATION

Card-access, safety, security and entry systems shall comply with this section.

DESIGN REQUIREMENTS

Adequate lighting shall be provided continuously along public walkways, steps and *ramps* that are actively used at all times of year and/or where staff and public parking is provided.

Where public telephones are installed, an *accessible* public telephone complying with Section 1.3.3 Public Telephones shall be located at, or close to an *accessible entrance*, for the use of persons requiring assistance.

Card-entry systems shall

- be wall-mounted, 800 mm - 900 mm (31-1/2 in. - 35-1/2 in.) above the floor or ground, adjacent to the door and free of the door swing;
- be located no closer than 700 mm (27-1/2 in.) from an inside corner, for side-access to the card-entry system;
- be located no closer than 400 mm (15-3/4 in.) from an inside corner, for front-access to the card-entry system;
- be *colour contrasted* from the surface on which they are mounted;
- provide both audible (beep) and/or verbal prompt (welcome) and visual (light) signals to indicate that access has been granted;
- where a card entry system is used that incorporates a card-slot, the card-slot shall have bevelled edges;
- be illuminated or *colour contrasted* from the mounting plate;
- include *tactile* graphic symbols on the surrounding surface that represents the card and its orientation for insertion; and
- use cards that incorporate a distinctive colour, texture or raised graphic/lettering on

one side.

Intercom entry systems shall

- comply with Section 3.5.1 Controls and Operating Mechanisms;
- provide both visual and verbal features to provide access for persons with vision, hearing or speech *impairments*; and
- provide both audible (beep) and visual (light) signals to indicate that access has been granted.

RELATED SECTIONS

- 1.1.1 Space and Reach Requirements
- 1.1.3 Accessible Routes, Paths and Corridors
- 1.2.1 Texture, Finishes and Colour
- 2.1.2 Exterior Lighting
- 2.1.3 Streetscape
- 3.1.2 Entrances
- 3.1.3 Doors
- 3.1.5 Elevators
- 3.1.6 Platform Lifts
- 3.2.3 Offices, Work Areas and Meeting Rooms
- 3.3.7 Individual Washrooms
- 3.5.1 Controls and Operating Mechanisms
- 3.5.3 Interior Lighting

3.5.3 Interior Lighting

RATIONALE

Artificial lighting and natural light sources should provide comfortable, evenly distributed light at all working areas, in all circulation routes and in all areas of potential hazard.

APPLICATION

Interior lighting systems shall comply with this section.

DESIGN REQUIREMENTS

Light sources and fixtures shall be selected to minimize direct glare or indirect glare on nearby reflective surfaces.

Light sources shall provide as full a spectrum of light as possible, as an aid to edge and colour definition.

Lighting shall be configured to create an even distribution at floor level and to minimize pools of light and areas of shadow.

The leading edge of stairs, steps, *ramps* or escalators shall be evenly lighted to minimize tripping hazards.

Lighting levels in elevator lobbies shall be similar to the lighting levels in elevator cabs, to minimize tripping hazards, and in no case shall be less than 200 lux (20 ft-candles).

Lighting levels in washrooms and dressing rooms shall be evenly distributed and no less than 200

lux (20 ft-candles).

Lighting levels in office areas shall be evenly distributed and no less than 300 lux (30 ft-candles).

Emergency lighting over stairs and *ramps*, in an exit or path of travel, shall be at least 10 lux (1 ft-candle).

Lighting over directional or informational *signage*, or highlighting other orientation features, at public telephones, information or service counters, and card or keypad security systems, shall be no less than 200 lux (20 ft-candles) at the working surface.

Lighting in *meeting rooms* and *assembly areas* shall be evenly distributed, and shall be capable of being adjusted (e.g., dimmers).

Lighting at lecterns, podiums/platforms or other speaker locations shall be capable of being enhanced, even when other lighting is dimmed, to permit ease of lip-reading and/or viewing of the hand actions of a nearby signer for persons who are deaf.

RELATED SECTIONS

All relevant parts of Sections 1.0 General Design Standards, 2.0 Exterior Design Standards and 3.0 Interior Design Standards.

INTERIOR STANDARDS

3.5.4 Interior Glare and Light Sources

RATIONALE

Direct or reflected glare off of floors, walls or work surfaces is uncomfortable for all users and a barrier to persons with reduced vision. Therefore, every attempt should be made to select light sources, materials and finishes which do not add to the problem, and to ensure that natural daylight is controllable.

The strategic use of lighting is valuable to all individuals, and especially important for individuals with some form of vision *impairment*. In addition, offering a variety of task lighting at work areas is beneficial to all.

APPLICATION

Systems used to control glare and excessive reflected light shall comply with this section.

DESIGN REQUIREMENTS

Monolithic floor surfaces, such as stone, granite, marble or terrazzo, shall have a matte or honed finish, to minimize reflected glare. Extensive high-gloss floor finishes are not acceptable but high-gloss materials may be incorporated into floor finish details, as long as they do not result in large reflective surfaces.

Finishes such as vinyl, other composition materials, quarry tile, glazed tile or mosaics, used on horizontal surfaces, such as floors and work surfaces, shall be in matte or satin finishes.

Extensive high gloss floor finishes are not acceptable, but high-gloss materials may be incorporated into floor finish details, as long as they do not result in large reflective surfaces and/or slip hazards.

Finishes such as paint, vinyl wall coverings, stone, marble, wood, metals, plastic laminate, etc., used on vertical surfaces, such as walls and columns, shall have matte or satin finishes. Extensive high-gloss wall finishes are not acceptable, but high-gloss materials may be incorporated into wall finish details, as long as they do not result in large reflective surfaces.

Curtains, blinds or other sun-screening systems shall be provided at windows and other places where direct sunlight can adversely affect the level of lighting and/or reflected glare.

Light fixtures shall be selected with diffusers, lenses or recessed light sources, so that minimal glare is created.

If surface mounted fluorescent ceiling fixtures are mounted below 2440 mm (96 in.), they shall have darkened sides (i.e., not wrap-around lenses) and be positioned perpendicular to the dominant direction of travel, or used in valance-type lighting at the sides of the *space*, so that the lighting is indirect.

The location of special features and key orientation *elements*

shall be enhanced through the use of supplementary lighting. Such lighting shall have upward or downward components only.

RELATED SECTIONS

- 1.1.3 Accessible Routes, Paths and Corridors
- 1.1.6 Stairs
- 3.1.1 Interior Floor Surfaces
- 3.1.2 Entrances
- 3.1.4 Windows, Glazed Screens and Sidelights
- 3.1.5 Elevators
- 3.1.6 Platform Lifts
- 3.1.7 Escalators
- 3.2.1 Information, Reception and Service Counters
- 3.3.1 Toilet and Bathing Facilities
- 3.5.3 Interior Lighting

3.6.1 Arenas, Gymnasiums, Halls and Other Indoor Recreational Facilities

RATIONALE

Opportunities for recreation, leisure and active sport participation should be available to all members of the community. Access should be provided to halls, arenas, and other sports *facilities*, including access to the *site*, all activity *spaces*, gymnasias, fitness *facilities*, lockers, change rooms and showers. Persons with a *disability* may be active participants, as well as spectators, volunteers and members of staff.

APPLICATION

Arenas, halls and other indoor recreation *facilities* shall comply with this section.

Where dressing *facilities* are provided for use by the general public, clients, customers, performers or staff, at least 50%, but never less than one, for each type of use in each cluster of dressing *facilities* shall be *accessible* and in compliance with Section 3.2.6 Specialty Change Rooms. It is preferable to have all dressing *facilities accessible*.

DESIGN REQUIREMENTS

Arenas, halls and other indoor recreation *facilities* shall include the following:

- where visitor, spectator and/or participant seating is provided, have *accessible* seating options in compliance with Section 1.3.4 Elevated Areas and Platforms;
- an *accessible route* to the arena/*facility* floor in compliance with Section 1.1.3 Accessible Routes, Paths and Corridors;
- one accessible entrance through a public access gate which is at least 950 mm (37-1/2 in.) wide, onto the ice surface from the public area. Other gates from the penalty and players boxes may be narrower;
- where *facilities* are provided for performances and other events, they shall have a direct *accessible route* from the lobby/*entrances* and viewing locations to all performing areas, including stages, dressing rooms, washrooms and all other *spaces* used by performers in compliance with Section 1.1.3 Accessible Routes, Paths and Corridors;
- where dressing *facilities* are provided, have dressing *facilities* that comply with Section 3.2.6 Specialty Change Rooms;
- where lockers or shelving is provided they shall comply with Sections 3.2.5 Storage, Shelving and Display Units and 3.2.7 Lockers and Storage Units;
- where coat hooks are provided, have at least 10%, but never less than one, within the reach ranges specified in Section 1.1.1 Space and Reach Requirements;
- where toilets and bathing *facilities* are provided, have toilets and bathing *facilities* that comply with Section 3.3.1 Toilet and Bathing Facilities;
- where concessions or other service counters are provided, comply with Section 3.2.1 Information, Reception and Service Counters;
- where swimming pool, hot pools or therapy pools are provided, they comply with Sections 1.4.1 Swimming Pools.

RELATED SECTIONS

All relevant parts of Sections 1.0 General Design Standards, 2.0 Exterior Design Standards and 3.0 Interior Design Standards.

3.6 INTERIOR CONTEXT SPECIFIC REQUIREMENTS

INTERIOR STANDARDS

3.6.2 Cafeterias

RATIONALE

Cafeteria serving lines and seating areas needs to reflect the lower sight lines, reduced reach, knee-space and maneuvering requirements of persons using wheelchairs or scooters. Patrons using mobility devices may not be able to hold a tray or food items while supporting themselves on canes or maneuvering a wheelchair. Tray slides should be designed to move trays with a minimum of ease. Continuous tray slides with *colour contrasted* stops are preferred.

Tables with straight legs at the corners or cantilevered tables, are preferred over pedestal tables.

APPLICATION

Cafeterias shall comply with this section.

Where fixed tables or counters are provided, at least 10%, but not less than one, shall be *accessible* and shall comply with Section 3.2.2 Tables, Counters and Work Surfaces. It is preferable to have all fixed tables *accessible*.

In new construction, and where practicable in *alterations*, the fixed tables (or counters) shall be distributed throughout the *space of facility*.

At least one lane at each cashier area shall be *accessible* and comply with this section. It is preferable to have all lanes at all cashier areas *accessible*.

DESIGN REQUIREMENTS

Where food or drink is served at counters exceeding 865 mm (34 in.) in height for use by customers seated on stools or standing at the counter, a portion of the main counter which is 1525 mm (60 in.) in length (minimum) shall be provided in compliance with Section 3.2.1 Information, Reception and Service Counters, or service shall be available at *accessible* tables within the same area.

All *accessible* fixed tables shall be *accessible* by means of an *access aisle* at least 1100 mm (43-1/4 in.) *clear* between parallel edges of tables or between a wall and the table edges.

Dining areas, including raised or sunken dining areas, and outdoor seating areas shall be *accessible*. In a *retrofit* situation where it is *technically not feasible* to provide access to all levels within a dining area, or to all parts of outdoor seating areas, at least one dining area shall be *accessible*. The *accessible* area must feature the same level of service and décor as the rest of the dining area and it must not be restricted to use by people with *disabilities*.

Food service lines shall have a minimum *clear* width of 1100 mm (43-1/4 in.).

Tray slides shall be mounted no higher than 865 mm (34 in.).

If self-service shelves are pro-

vided, at least 50% must be within the reach ranges specified in Section 1.1.1 Space and Reach Requirements. It is preferable to have all self-service shelves *accessible*.

Self-service shelves and dispensing devices for tableware, dishware, condiments, food and beverages shall be installed to comply with Section 1.1.1 Space and Reach Requirements.

Food behind glass doors shall have large print and Braille labels on the door.

Where menus are posted on a wall near the *entrance*, they shall be centred 1500 mm (59 in.) from the floor.

In banquet rooms or *spaces* where a head table or speaker's lectern is located on a raised platform, the platform shall be *accessible* in compliance with Sections 1.1.5 Ramps or 1.3.4 Elevated Areas and Platforms, as well as 3.1.6 Platform Lifts.

Spaces for vending machines, beverage dispensers and other equipment shall comply with Section 1.1.1 Space and Reach Requirements and shall be located on an *accessible route* in compliance with Section 1.1.3 Accessible Routes, Paths and Corridors.

Cashier locations should feature at least one *access aisle*, which is a minimum of 1100 mm (43-1/4 in.) wide. It is preferable to have

3.6 INTERIOR CONTEXT SPECIFIC REQUIREMENTS

3.6.2 Cafeterias (continued)

all aisles *accessible*.

Barriers and/or turnstiles, where provided to control access, shall comply with Section 1.1.4 Gates, Turnstiles and Openings.

Queuing areas shall comply with Section 1.3.5 Waiting and Queuing Areas.

Access to outdoor eating areas shall comply with Section 2.2.1 Balconies, Plazas and Patios.

RELATED SECTIONS

All relevant parts of Sections 1.0 General Design Standards, 2.0 Exterior Design Standards and 3.0 Interior Design Standards.

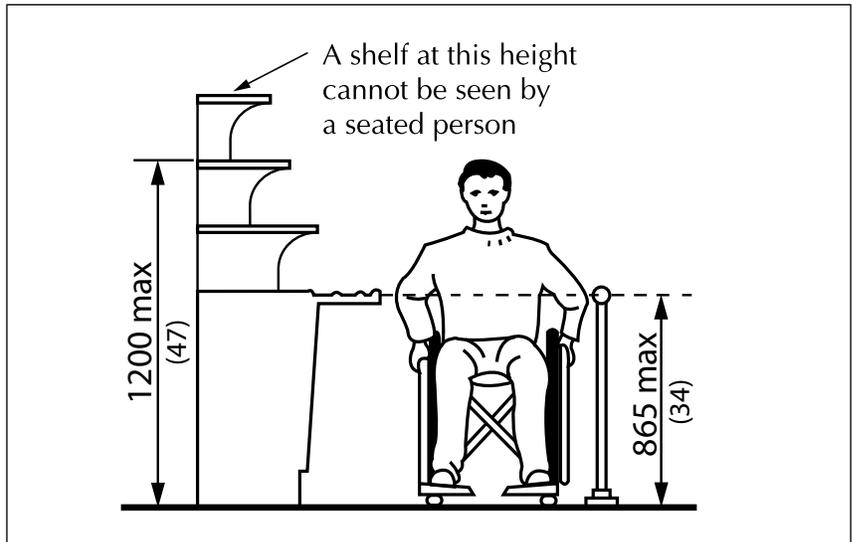

Figure 3.6.2.1 Shelf Heights

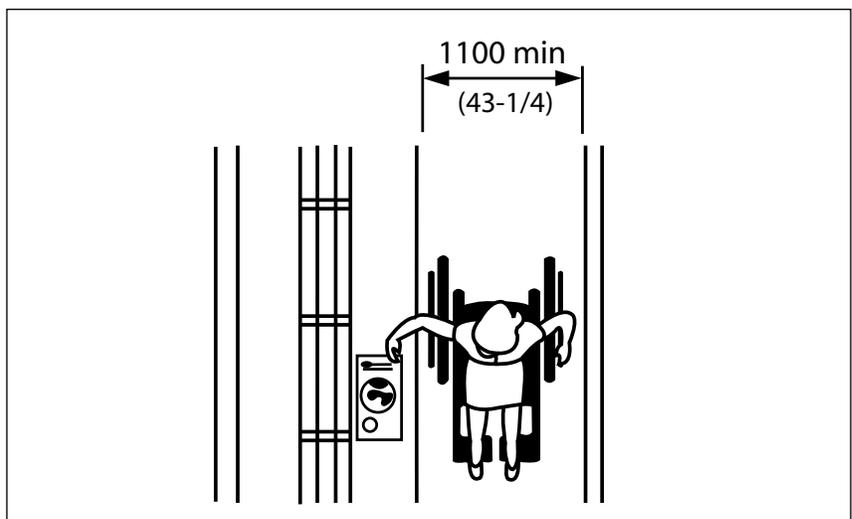

Figure 3.6.2.2 Aisle Width

3.6 INTERIOR CONTEXT SPECIFIC REQUIREMENTS

3.6.3 Libraries

RATIONALE

Traditional and automated systems should be available to all patrons and staff. Both the design of the *facility* and the provision of services should be considered. Service counters and study carrels should accommodate the knee-space and armrest requirements of persons using wheelchairs. On-Line catalogues, carrels and workstations should be provided at a range of heights, to accommodate persons who are standing or sitting, as well as children of many ages and sizes.

The provision of workstations equipped with assistive technology such as large displays, screen readers, etc. will increase the accessibility of a library.

APPLICATION

Libraries shall comply with this section.

Where fixed seating, tables or study carrels are provided, at least 10% but no less than one shall be *accessible* and in compliance with this section. It is preferable to have all fixed seating, tables and study carrels *accessible*.

At least one location at each checkout area shall be *accessible* and comply with this section. It is preferable to have all locations at checkout areas *accessible*.

Where computer catalogues or workstations are provided, at least 10% but no less than one shall

be *accessible* and shall comply with this section. It is preferable to have all computer catalogues and workstations *accessible*.

DESIGN REQUIREMENTS

Accessible fixed seating, tables and study carrels shall be located on an *accessible route* in compliance with Section 1.1.3 Accessible Routes, Paths and Corridors.

Clearances between fixed seat-

ing, tables and study carrels shall comply with Section 1.1.3 Accessible Routes, Paths and Corridors.

Where shelving is provided at fixed seating, tables or study carrels, the shelving shall be no higher than 1370 mm (54 in.) from the floor to the bottom of the highest shelf.

Accessible fixed study carrels shall incorporate

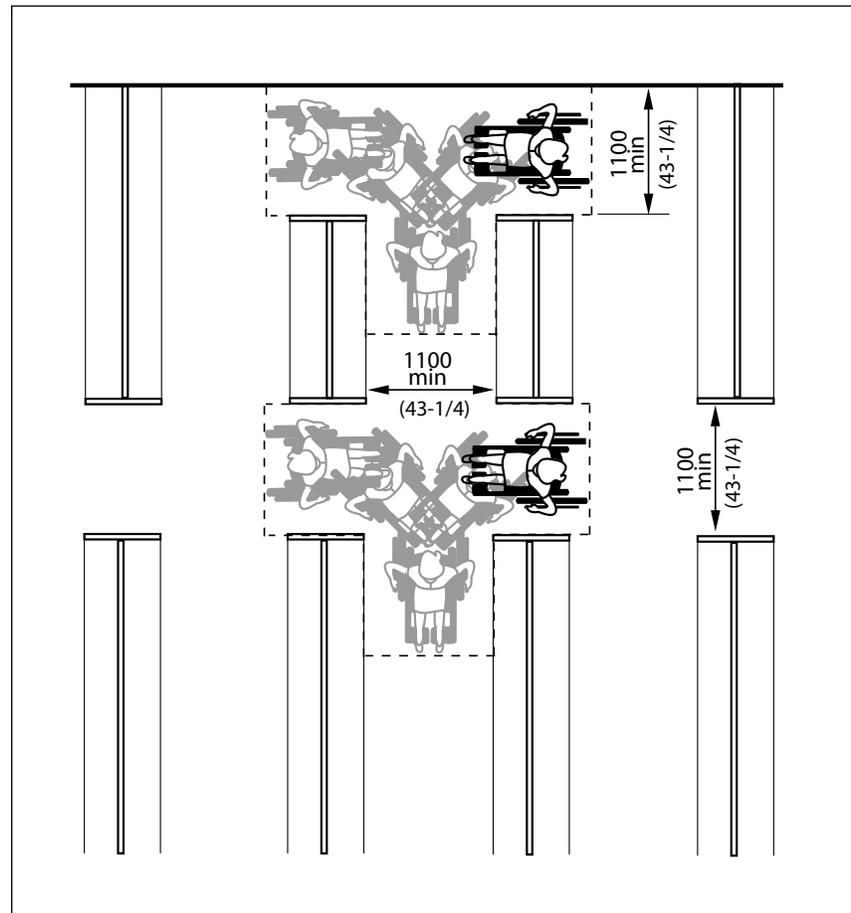

Figure 3.6.3.1 Library Stack Aisle Width

3.6.3 Libraries (continued)

- work surfaces and knee/toe clearance in compliance with Section 1.1.1 Space and Reach Requirements;
- an electrical outlet; and
- general lighting levels of at least 200 lux (18.6 ft-candles) at the work surface, with task lighting capable of increasing the illumination of the work surface to at least 500 lux (50 ft-candles).

Where provided, traffic control or book security gates shall comply with Section 1.1.4 Gates, Turnstiles and Openings.

Minimum *clear aisle space* at stacks shall comply with Section 1.1.1 Space and Reach Requirements. Aisle configurations shall incorporate a *clear space* allowing a person in a wheelchair to make a 180-degree turn.

Maximum reach heights at card catalogues shall comply with Section 1.1.1 Space and Reach Requirements.

Circulation service counters and information service counters shall comply with Section 3.2.1 Information, Reception and Service Counters.

Where provided, computer catalogue or computer workstation shall incorporate

- knee and toe *space* below in compliance with Sections 1.1.1 Space and Reach Requirements and 3.2.2 Tables, Counters and Work

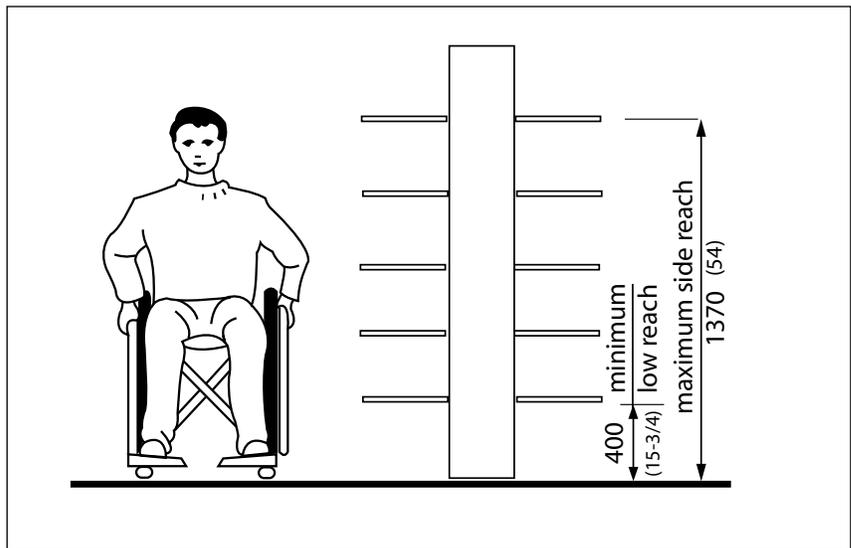

Figure 3.6.3.2 Library Stack Reach Heights

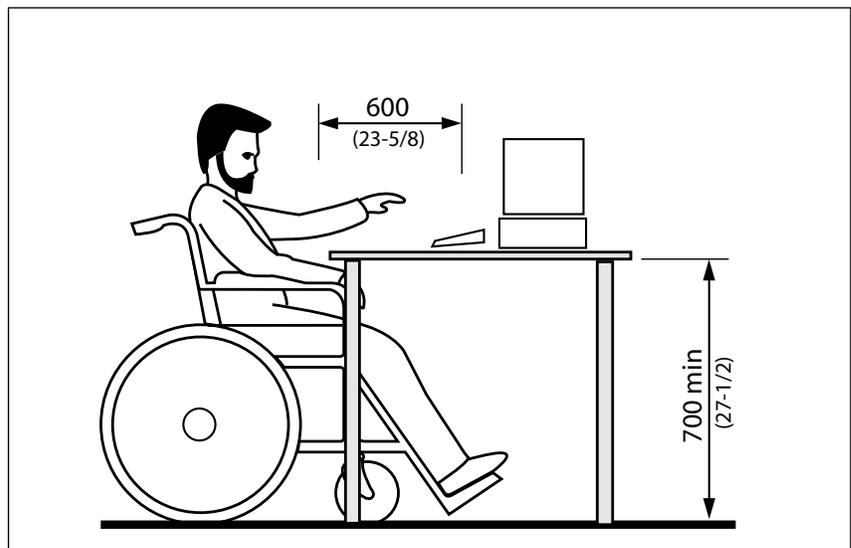

Figure 3.6.3.3 Work Surfaces

3.6 INTERIOR CONTEXT SPECIFIC REQUIREMENTS

INTERIOR STANDARDS

3.6.3 Libraries (continued)

- Areas;
- a maximum work surface height of 865 mm (34 in.); and
 - a maximum table depth of 900 mm (35 in.).

A minimum of one movable chair shall be provided at every information service counter, computer catalogue or computer workstation.

Book drop slots shall

- be located on an *accessible route* complying with 1.1.3;
- be located adjacent to a 2440 by 2440 mm (96 by 96 in.) level platform. In a *retrofit* situation where it is *technically not feasible* to create a 2440 x 2440 mm (96 by 96 in.) platform, the platform may be reduced to 1525 x 1525 mm (60 by 60 in.); and
- have a slot that is operable using one hand, located between 860 mm (34 in.) and 900 mm (35 in.) above the floor.

Lighting at book stacks should preferably be mounted directly over the aisle *space* and provide a minimum of 200 lux (20 ft-candles) at a nominal working height of 920 mm (36 in.).

The acoustic quality shall be free of unnecessary background noise and should permit comprehension by persons with limited hearing.

Where CDs tapes, talking books, etc. are available as part of the

library resource materials, or for loan purposes, a separate *space* shall be provided for auditing this material without disturbing other library users. An acceptable alternative would be to provide headphones for use.

RELATED SECTIONS

All relevant parts of Sections 1.0 General Design Standards, 2.0 Exterior Design Standards and 3.0 Interior Design Standards.

3.6.4 Cashier and Workplace Accommodations

RATIONALE

Work spaces should be designed with a view to future adaptation or accommodation of individual equipment or assistive devices.

APPLICATION

Business, mercantile and civic *facilities* shall comply with this section.

In areas used for transactions where counters have cash registers and are provided for sales and distribution of goods or services to the public, at least one of each type shall have a portion of the counter *accessible* and in compliance with this section.

Where counters are dispersed throughout the *facility*, the *accessible* counters must also be dispersed throughout the *facility*.

In public *facilities* where counters or teller windows have solid partitions or security glazing to separate personnel from the public, at least one of each type shall provide a method to facilitate voice communication such as grills, slats, talk-through baffles, intercoms or telephone handset devices.

Accessible checkout aisles shall be provided in conformance with Table 3.6.4.1.

DESIGN REQUIREMENTS

All *accessible* sales and service counters shall be on an *acces-*

sible route that complies with Section 1.1.3 Accessible Routes, Paths and Corridors.

In areas used for transactions where counters have cash registers and are provided for sales and distribution of goods or services to the public, the counter shall have provision for a transaction counter that is at least 920 mm (36 in.) in length, with a maximum height of 865 mm (34 in.) above the finished floor.

Areas used for transactions that may not have a cash register but at which goods and services are sold, including, but not limited to, ticketing counters, teller stations, registration counters, information counters, box office counters and library check-out areas, shall comply with Section 3.2.1 Information, Reception and Service Counters.

Where counters or teller windows have solid partitions or security glazing to separate personnel from the public, the method of communication provided shall be *accessible* to both individuals who use wheelchairs and individuals who have difficulty bending.

The *clear* width of *accessible*

checkout lines shall comply with 1.1.3, and the maximum adjoining counter height shall not exceed 965 mm (38 in.) above the finished floor. The top of the lip shall not exceed 1015 mm (40 in.) above the finished floor.

Signage identifying *accessible* checkout aisles shall incorporate the international symbol of access and shall be mounted above the checkout aisle in the same location where the checkout number or type of checkout is displayed.

Any devices used to prevent the removal of shopping carts from store premises shall not prevent access or *egress* to people in wheelchairs. An alternate *entrance* that is equally convenient to that provided for ambulatory persons is acceptable.

- Retail *spaces* shall
- have *access aisles* at least 1200 mm (47 in.) wide; and
 - no retail items located above 1370 mm (54 in.).

RELATED SECTIONS

All relevant parts of Sections 1.0 General Design Standards, 2.0 Exterior Design Standards and 3.0 Interior Design Standards.

Total checkout aisles of each design	Minimum number of accessible checkout aisles of each design
1-4	1
5-8	2
9-15	3
Over 15	3 plus 20% of additional aisles

Table 3.6.4.1 Required Number of *Accessible* Check-out Aisles

3.6 INTERIOR CONTEXT SPECIFIC REQUIREMENTS

INTERIOR STANDARDS

3.6.5 Emergency Services

RATIONALE

Emergency services should accommodate persons with *disabilities*, who may be members of the public detainees, members of counsel or staff. All areas of emergency service stations that are used by the public, members of staff and counsel should be *accessible* to persons with *disabilities*. Secure areas, such as police holding cells and common areas used by detainees, should have provisions to *accommodate* persons with *disabilities*.

APPLICATION

Except as specified in this section, all *common use areas* serving *accessible* cells or rooms and all *public use areas* shall be designed and constructed to comply with Sections 1.0 General Design Standards, 2.0 Exterior Design Standards and 3.0 Interior Design Standards.

Exceptions: Requirements for areas of rescue assistance in Section 3.1.8 Emergency Exits, Fire Evacuation and Areas of Rescue and Assistance do not apply. Compliance with requirements for elevators and stairs is not required in multi-storey housing *facilities* where *accessible* cells or rooms, all *common use areas* serving them and all *public use areas* are located on an *accessible route*.

Entrances used by the public, including those that are secured, shall be *accessible* to comply with

Section 3.1.2 Entrances.

Exception: Secured *entrances*, doors and doorways operated only by security personnel shall not be required to have *accessible* door hardware.

Where security systems are provided at public or other *entrances* required to be *accessible* by this section, an *accessible route* complying with Section 1.1.3 Accessible Routes, Paths and Corridors shall be provided through fixed security barriers at required *accessible entrances*. Where security barriers incorporate equipment such as metal detectors, fluoroscopes, or other similar devices which cannot be made *accessible*, an *accessible route* shall be provided adjacent to such security screening devices, to facilitate an equivalent *circulation path*.

In non-contact visiting areas where detainees are separated from visitors, the following *elements*, where provided, shall be *accessible* and located on an *accessible route* complying with Section 1.1.3 Accessible Routes, Paths and Corridors.

Requirements for cubicles and counters:

- 5%, but not less than one, shall comply with Section 3.2.2 Tables, Counters and Work Surfaces on both the visitor and detainee sides;
- where counters are provided, they shall comply with Section

3.2.1 Information, Reception and Service Counters on both the visitor and detainee sides.

Exception: Non-contact visiting areas not serving *accessible* cells or rooms.

Requirements for partitions:

Solid partitions or security glazing separating visitors from detainees through which communication is necessary shall incorporate communication systems which are *accessible* to both individuals who use wheelchairs and individuals who have difficulty bending. If such communication systems incorporate a telephone handset, at least one telephone handset shall be equipped with a volume control.

At least 2%, but not less than one, of the total number of cells shall comply with this section. Where special cells are provided (e.g., orientation, protective custody, disciplinary, segregation, detoxification or medical isolation), at least one of each purpose shall comply with this section.

In addition to the aforementioned cell requirements, at least 2%, but not less than one, of general cells shall be equipped with audible emergency warning systems in compliance with this section.

Medical care facilities providing physical or medical treatment or care shall be *accessible* to persons with *disabilities*.

3.6 INTERIOR CONTEXT SPECIFIC REQUIREMENTS

3.6.5 Emergency Services (continued)

- all doors and doorways on an *accessible route* shall comply with Sections 3.1.3 Doors. Exception: Secured *entrances*, doors and doorways operated only by security personnel shall not be required to have *accessible* door hardware;
- at least one toilet and one bathing facility shall comply with Sections 3.3.1 Toilet and Bathing Facilities;
- *accessible* beds shall have maneuvering *space* at least 920 mm (36 in.) wide along one side;
- at least one drinking fountain and/or water cooler shall comply with Sections 1.3.1 Drinking Fountains;
- fixed or built-in tables, counters or work surfaces shall comply with Sections 3.2.2 Tables Counters and Work Surfaces;
- at least one fixed bench shall comply with Sections 1.3.6 Benches;
- fixed or built-in storage shall comply with Sections 3.2.5 Storage, Shelving, and Display Units;
- all controls intended for operation by detainees shall comply with Sections 3.5.1 Controls and Operating Mechanisms.

Where audible emergency warning systems are provided to serve occupants of cells, visual alarms complying with Sections 3.4.1 Visual Alarms shall also

be provided. Exception: Visual alarms are not required where detainees are not allowed independent means of *egress*.

Where permanently installed telephones are provided within cells, they shall have volume controls.

RELATED SECTIONS

All relevant parts of Sections 1.0 General Design Standards, 2.0 Exterior Design Standards and 3.0 Interior Design Standards.

3.6.5 Public Housing

RATIONALE

Persons with *disabilities* should have equitable access to housing choices. They should also have the opportunity to visit family, neighbours and friends within their homes.

Accessible housing will incorporate features throughout the house to accommodate a family member who uses a wheelchair, scooter or other type of mobility aid.

Visitable housing will incorporate basic access features to accommodate visitors with *disabilities*, elderly persons or residents who may be temporarily *disabled*. Basic access includes the ability to enter safely, maneuver throughout the *entrance*-level of the house, and *space* to access a toilet.

APPLICATION

All public housing units shall be *visitable* and shall comply with this section.

10% of all public housing units shall be *accessible* and shall comply with this section.

The *common-use* areas of public housing *facilities* shall comply with all relevant sections of this manual.

DESIGN REQUIREMENTS

Visitable public housing units shall comply with the 'Visitable

Dwelling Units' section of CAN/CSA B651: Accessible design for the built environment (most current version).

Accessible public housing units shall comply with the most current version of the 'Accessible Dwelling Units' section of CAN/CSA B651: Accessible Design for the Built Environment.

RELATED SECTIONS

All relevant parts of Sections 1.0 General Design Standards, 2.0 Exterior Design Standards and 3.0 Interior Design Standards.

3.6.6 Training Facilities

RATIONALE

Students, teachers and staff with *disabilities* should have equitable access to school facilities.

This section of the manual identifies general accessibility requirements that are applicable to all areas of training facilities.

Students teachers and staff with *disabilities* should be accommodated in all classrooms and other learning *spaces* throughout a school. Basic accommodation includes the ability to enter and move freely throughout the *space*, as well as use the various built-in *elements* within (i.e. blackboards, switches, computer stations, sinks, etc). Individual students with a *disability* may require additional accommodations beyond those identified within this section.

Where built-in *elements* are duplicated within an individual classroom/learning *space*, such as laboratory benches or pinboards, at least one of each type of *element* should be *accessible* to students, teachers and staff with *disabilities*.

Wherever possible, fixtures, fittings, furniture and equipment should be specified for classrooms and other learning *spaces*, which is usable by students, teachers and staff with *disabilities*. However, it is recognized that not all equipment found in classrooms and other learning *spaces* is usable by persons

with *disabilities* - such as heavy machinery found in trades and technology classrooms.

APPLICATION

All classrooms and other learning *spaces* shall be *accessible* and shall comply with this section. Where built-in *elements* such as fixed seating, tables or laboratory benches are provided within a classroom/learning *space*, at least 10% but no less than one, shall be *accessible* and in compliance with this section.

At least 50% of shelf *space* in storage facilities in classroom/learning *spaces* shall comply with this section.

Classroom 'portables' shall comply with this section.

The *common-use* areas of school *facilities* shall comply with all relevant sections of this manual.

DESIGN REQUIREMENTS

Classrooms and other training *spaces* shall incorporate

- at least one entry/*egress* door in compliance with Sections 3.1.3 Entrances;
- floor surfaces throughout in compliance with Sections 3.1.1 Interior Floor Surfaces;
- primary circulation routes in compliance with Sections 1.1.1 Space and Reach Requirements, linking all functional areas and *elements* within the *space*;

- secondary circulation routes no less than 920 mm (36 in.) wide;
- controls and operating mechanisms in compliance with Sections 3.5.1 Controls and Operating Mechanisms; and
- windows, glazed screens and sidelights in compliance with Section 3.1.4 Windows, Glazed Screens and Sidelights.

Classrooms, auditoriums, *assembly areas* and other training *spaces* that incorporate fixed seating shall

- incorporate *accessible* seating in compliance with Section 1.3.4 Elevated Areas and Platforms; and
- where applicable, incorporate assistive listening systems in compliance with Section 3.4.2 Assistive Listening Systems.

Where classrooms or other training *spaces* incorporate safety equipment such as fire extinguishers, eye-baths or deluge showers, such equipment shall be *accessible* to and usable by persons with *disabilities*.

Accessible work surfaces and other built-in *elements* within classrooms and other training *spaces* shall

- comply with Section 3.2.2 Tables, Counters and Work Surfaces;
- where applicable, incorporate controls and operating mechanisms in compliance with

INTERIOR STANDARDS

3.6.6 Training Facilities

- Section 3.5.1 Controls and Operating Mechanisms; and
- be large enough to accommodate an assistant and extra equipment.

Accessible storage elements within classrooms and other training spaces shall

- be located on an *accessible route* with adjacent *clear space* in compliance with Section 1.1.1 Space and Reach Requirements;
- comply with at least one of the reach ranges specified in Section 1.1.1 Space and Reach Requirements; and
- incorporate *operable portions* that comply with Section 3.5.1 Controls and Operating Mechanisms.

Where pin boards, blackboards, or other display systems are provided within classrooms and other training spaces, at least one of each type shall

- be located on an *accessible route* with adjacent *clear space* in compliance with Section 1.1.1 Space and Reach Requirements; and
- have its lowest edge located no higher than 760 mm (30 in.).

Where classrooms or other training spaces incorporate demonstration areas such as laboratory benches, fume cabinets or computer stations, provisions must be made to facilitate viewing from a variety of eye-levels. The instal-

lation of mirrors over the demonstration areas is one way to provide such access.

Classrooms and other spaces intended for general teaching and study shall feature a background noise level no higher than 30 dB(A).

Lockers shall comply with Section 3.2.7 Lockers and Storage Units.

Where classrooms and other training spaces incorporate sinks, at least one shall

- be located on an *accessible route* with adjacent *clear space*;
- where a forward approach is provided, incorporate knee space below at least 760 mm (30 in.) wide, 480 mm (18-7/8 in.) deep, and 685 mm (27 in.) high;
- have the height of the rim or the counter top (whichever is higher) 710 mm - 856 mm (28 in. - 34 in.);
- incorporate faucets and other controls in compliance with Section 3.5.1 Controls and Operating Mechanisms;
- have water supply and drain pipes under the sink insulated or otherwise configured to protect against contact; and
- incorporate no sharp or abrasive surfaces under the sink.

Where classrooms and other training spaces incorporate kitchens, each kitchen shall

- if of a pass-through configu-

ration, have two entries and where counters, appliances or cabinets are on two opposing sides, or when counters, appliances or cabinets are opposite a parallel wall, clearance between all opposing base cabinets, counter tops, appliances, or walls within a kitchen work area shall be 1100 mm (43-1/4 in.) minimum;

- if of a U-shaped configuration enclosed on three contiguous sides, have a minimum clearance of 2440 mm (96 in.) between all opposing base cabinets, counter tops, appliances, or walls within kitchen work areas. In a *retrofit* situation where providing a 2440 mm (96 in.) space is technically not feasible, the space between opposing base cabinets, counter tops, appliances, or walls within kitchen work areas may be reduced to 2130 mm (84 in.);
- incorporate at least one work surface minimum 920 mm (36 in.) wide, located maximum 865 mm (34 in.) high, with knee space below at least 760 mm (30 in.) wide, 480 mm (18-7/8 in.) deep, and 685 mm (27 in.) high; and
- incorporate *elements* that feature *colour contrast* to visually differentiate the cabinets and appliances from adjacent wall and floor surfaces, the countertop from the cabinets and adjacent walls, and operable hardware on cabinets.

Work surfaces shall incorporate

3.6 INTERIOR CONTEXT SPECIFIC REQUIREMENTS

3.6.6 Training Facilities

non-glare finishes.

Where classrooms and other training spaces incorporate appliances, at least one of each type of appliance shall

- be located on an *accessible route* with adjacent *clear space* in compliance with Section 1.1.1 Space and reach Requirements; and
- incorporate controls and *operable portions* that comply with Section 3.5.1 Controls and Operating Mechanisms. Exceptions: Appliance doors and door latching devices.

Where classrooms and other training spaces incorporate dishwashers, the dishwashers shall incorporate *clear space* adjacent to the dishwasher door. The dishwasher door, in the open position, shall not obstruct the *clear space* for the dishwasher or the sink.

Where classrooms and other training spaces incorporate ranges and/or cooktops, they shall

- incorporate controls that are located to avoid reaching across the burners; and
- where a forward approach is provided incorporate knee space below at least 760 mm (30 in.) wide, 480 mm (18-7/8 in.) deep and 685 mm (27 in.) high; and
- insulate or otherwise configure the appliance to prevent burns, abrasions, or electrical shock.

Where classrooms and other training spaces incorporate refrigerators/freezers, they shall

be configured with at least 50% of the freezer space 1370 mm (54 in.) maximum above the floor; and incorporate *clear space* positioned for a parallel approach to the space dedicated for the refrigerator/freezer, with the centre-line of the *clear space* offset 610 mm (24 in.) from maximum from the dedicated space.

RELATED SECTIONS

All relevant parts of Sections 1.0 General Design Standards, 2.0 Exterior Design Standards and 3.0 Interior Design Standards.

APPENDIX A

APPENDIX A - UNIVERSAL DESIGN PRINCIPLES

APPENDIX A

UNIVERSAL DESIGN PRINCIPLES AND GUIDELINES

Version 2.0 - 4/1/97

Compiled by advocates of universal design, listed in alphabetical order: Bettye Rose Connell, Mike Jones, Ron Mace, Jim Mueller, Abir Mullick, Elaine Ostroff, Jon Sanford, Ed Steinfeld, Molly Story, and Gregg Vanderheiden

Major funding provided by: The National Institute on Disability and Rehabilitation Research, U.S. Department of Education

Copyright 1997 NC State University, The Center for Universal Design

UNIVERSAL DESIGN:

The design of products and environments to be usable by all people, to the greatest extent possible, without the need for adaptation or specialized design.

The authors, a working group of architects, product designers, engineers and environmental design researchers, collaborated to establish the following Principles of Universal Design to guide a wide range of design disciplines, including environments, products, and communications. These seven principles may be applied to evaluate existing designs, guide the design process and educate both designers and consumers about the characteristics of more usable products and environments.

The Principles of Universal Design are presented here, in the following format: name of the principle, intended to be a concise and easily remembered statement of the key concept embodied in the principle; definition of the principle, a brief description of the principle's primary directive for design; and guidelines, a list of the key elements that should be present in a design which adheres to the principle. (Note: all guidelines may not be relevant to all designs.)

PRINCIPLE ONE: Equitable Use

The design is useful and marketable to people with diverse abilities.

Guidelines:

- Provide the same means of use for all users: identical whenever possible; equivalent when not.
- Avoid segregating or stigmatizing any users.
- Provisions for privacy, security, and safety should be equally available to all users.
- Make the design appealing to all users.

PRINCIPLE TWO: Flexibility in Use

The design accommodates a wide range of individual preferences and abilities.

Guidelines:

- Provide choice in methods of

use.

- Accommodate right or left handed access and use.
- Facilitate the user's accuracy and precision.
- Provide adaptability to the user's pace.

PRINCIPLE THREE: Simple and Intuitive Use

Use of the design is easy to understand, regardless of the user's experience, knowledge, language skills, or current concentration level.

Guidelines:

- Eliminate unnecessary complexity.
- Be consistent with user expectations and intuition.
- Accommodate a wide range of literacy and language skills.
- Arrange information consistent with its importance.
- Provide effective prompting and feedback during and after task completion.

PRINCIPLE FOUR: Perceptible Information

The design communicates necessary information effectively to the user, regardless of ambient conditions or the user's sensory abilities.

Guidelines:

- Use different modes (pictorial, verbal, tactile) for redundant presentation of essential information.
- Provide adequate contrast

- between essential information and its surroundings.
- Maximize “legibility” of essential information.
 - Differentiate elements in ways that can be described (i.e., make it easy to give instructions or directions).
 - Provide compatibility with a variety of techniques or devices used by people with sensory limitations.

**PRINCIPLE FIVE:
Tolerance for Error**

The design minimizes hazards and the adverse consequences of accidental or unintended actions.

Guidelines:

- Arrange elements to minimize hazards and errors: most used elements, most accessible; hazardous elements eliminated, isolated, or shielded.
- Provide warnings of hazards and errors.
- Provide fail-safe features.
- Discourage unconscious action in tasks that require vigilance.

**PRINCIPLE SIX:
Low Physical Effort**

The design can be used efficiently and comfortably and with a minimum of fatigue.

Guidelines:

- Allow user to maintain a neutral body position.
- Use reasonable operating forces.

- Minimize repetitive actions.
- Minimize sustained physical effort.

**PRINCIPLE SEVEN:
Size and Space for Approach
and Use**

Appropriate size and space are provided for approach, reach, manipulation, and use, regardless of user’s body size, posture, or mobility.

Guidelines:

- Provide a clear line of sight to important elements for any seated or standing user.
- Make reach to all components comfortable for any seated or standing user.
- Accommodate variations in hand and grip size.
- Provide adequate space for the use of assistive devices or personal assistance.

Please note that the Principles of Universal Design address only universally usable design, while the practice of design involves more than consideration for usability. Designers must also incorporate other considerations, such as economic, engineering, cultural, gender, and environmental concerns, in their design processes. These principles offer designers guidance to better integrate features that meet the needs of as many users as possible.

APPENDIX B

APPENDIX B - CHANGE ORDER FORM

PROPOSED CHANGES TO THE
CITY OF WINNIPEG
FACILITY ACCESSIBILITY DESIGN MANUAL

Mail to: Universal Design Coordinator
Planning Property & Development Department
City of Winnipeg
15 – 30 Fort Street
Winnipeg, Manitoba, R3C 4X5

Name: _____

Address: _____

Organization: _____

Phone: _____

Email: _____

Proposed Change:
(include proposed new or revised wording, or identifications of wording to be deleted)

Reason for Change:

(attach additional information if required)

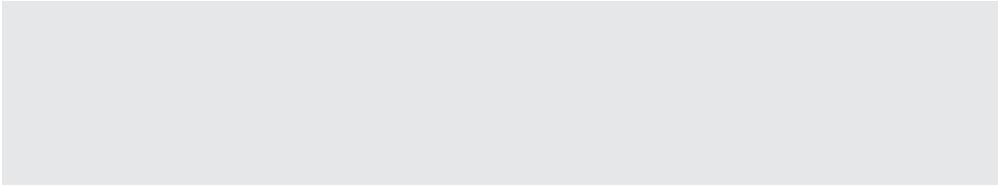

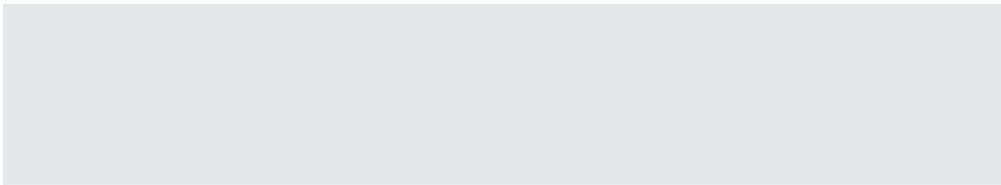

INDEX

INDEX

- Access aisle* 13
 Access Width (see Wheelchair)
Accessible 13
Accessible element 13
Accessible route 13, 30
 Accessible Planting Bed 90
Accessible space 13
Active transportation routes 13, 100
 Acoustics 45
Adaptable 13
Addition 13
Alteration 13
 Application 20, 21
 Appliances 139
Area of Rescue and Assistance 13, 130, 178
 Arenas 171
Assembly Area 13
 Acoustics 45
 Assembly Facilities 69, 165
Assistive Listening Device 13, 165
Assistive Listening Systems 13, 136, 165
Attic Space 13, 20, 31
Automatic Door 13
 Balconies 87
 Bathing Facilities 146
 Benches 30, 63
 Accessible Bench Example 64
 Along Accessible Routes 33
 at Rest Area 64
 Streetscape 78
 Waiting and Queuing Areas 62
 Bicycle Pathways 101
 Bike Racks 30
 Boardwalks 100
 Bus Passenger Shelters 104
 Bus Stop Platforms 104
 Cabinets 135
 Cafeterias 172
Cane Detectable 14, 44, 50, 52, 54
 Canopies 112
 Card Access 168
 Carpeting 110
 Cashier Accommodations 177
 Change Rooms (see Dressing Facilities)
Circulation Path 14
Clear Path of Travel 14
Clear space 14, 56, 105, 136, 137, 142, 148, 159, 162
 Clearances (see Wheelchair)
 Community Gardens 90
 Counters 132, 134, 137, 156, 172, 177
Closed-Circuit Telephone 14
Colour Contrast 14
Common Use 14
 Controls and Operating Mechanisms 56, 123, 137, 150, 152, 155, 166
 Cook Top 140
 Corridor 30, 31, 44
 \ 32
 Crawl Space 20, 31
Cross Slope 14, 31
Curb Ramp 14, 30, 32, 83
 Detectable Warning Surfaces 53, 83
 Diagrams 84, 85, 86
Detectable Warning 14, 44
 Systems 52
 Surfaces 52, 54, 84, 85, 86, 129
Disability 14
 Display Units 142
 Docks 102
 Dog Relief Areas 93
 Doors 114, 136, 143, 147, 158
 Toilet Stall Doors 149
 Dressing Facilities 100, 171
 Benches 143
 Rooms 143
 Drinking Fountains 54, 100, 102
 Clearances 55
 Edge Protection 30
 at ramps 39
Egress, Means of 14, 130
 Elevated Areas and Platforms 60
 Detectable Warning Surfaces 52, 61
 Elevator 30, 123
 Elevator Machine Room 20, 31
 Emergency Exits 130, 178
 Emergency Services 178
 Emergency Warning Systems 131
 Enforcement 9
Entrance 14, 21, 112
 Entrance Foyer 113
 Environmental Sustainability 21
 Escalators 129
 Exterior Ground Surfaces 74
Facility 15
 Faucets 152
 Fire Evacuation 130, 178
 Fixed Seating Assembly Facilities 69
 Floor Surfaces 110
 Freezer 139, 140
 Footbridges 100
 Gate 34
 Glare 170
 Glazed Screens 121
 Grab Bar 143, 146, 150, 154, 161, 162
 Toilet Grab Bar Configuration 151
Ground Floor 15
Guard 15, 29, 36, 42, 69
 Gymnasiums 171
 Halls 171
Handrail 15, 36, 42, 125, 143
 Dimensions 42
 at Pools 67
 at Ramps 39
 at Stairs 40
 Historic Place 68
 Illumination 33, 40
 Dressing Rooms 144
 Exterior Lighting 77
 Outdoor Recreational Facilities 102
 Public Telephones 57
 Signage 48
 Toilets and Bathing Facilities

INDEX

- 147
- Impairment* 15
- Implementation 9, 20
- Indicator Surface* 15
- Individual Washrooms 158
- Information Counter 132
- Information Systems 50
- Intercom System 168
- Interior Floor Surfaces 110
- Interior Glare and Light Sources 170
- Interpretive Panels 50
- Janitor Room 20, 31
- Kitchenettes 137, 183
- Kitchens 137, 183
- Lavatories 152
- Ledge Seating 65
- Libraries 174
- Lighting 136
 - Elevator 129
 - Exterior 77
 - Interior 169, 170, 176
- Lockers 145, 171
- Meeting Room* 15, 136
 - Acoustics 45
- Mezzanine* 15, 42
- Microwave 141
- Multi-Use Pathway* 15, 101
 - Detectable Warning Surfaces 53
- Natural Areas 102
- Newspaper Boxes 30
- Off-Street
 - Parking 94
- On-Street
 - Parking 94
 - Passenger Loading Zones 99
- Open Space* 15
- Operable Portion* 15
- Outdoor Pools 100
- Outdoor Recreational Facilities 100
- Oven 139, 141
- Overhead Objects 28
- Park* 15, 63, 79, 100, 101
- Parkette 101
- Parking 94, 103
- Parking Spaces 30, 94
- Passenger Loading Zones 30, 98
- Pathways 100
- Patios 78, 87
 - Permanent Patio 89
- Temporary Patio 88
- Pavers 74
- Picnic Tables 91, 102
- Pictograms 48, 49
- Plantings 90, 101
- Platform Lifts 127
- Play Areas 106
- Playgrounds 101
- Playing Fields 103
- Plazas 87
 - Pathway Across Plaza 88
- Power-Assisted Door* 15
- Privacy Screens 155
- Private Open Space* 15
- Protruding Objects 28
- Public Address Systems 46
- Public Historic Place* 15, 68
- Public Housing 180
- Public Right-of-Way* 16, 79
- Public Telephone 57
- Public Use* 16
- Queuing Areas 62
- Railing 32
- Ramps* 16, 30, 32, 36, 42, 66, 100
 - Detectable Warning Surfaces 52
 - Minimum Landing Dimensions 37
- Ramp Slope* 16, 36, 83
- Range 139
- Reach Requirements 24, 27, 139, 142, 173, 175
- Reception Counter 132
- Recreation Facilities (Indoor) 171
- Recreational Pathways 101
- Refrigerator 139, 140
- Rest Areas 101
- Retrofit* 16
- Roof Space* 16, 20
- Safety System 168
- Scooter
 - Clearances 26
 - Turning Space 25
- Security Systems 168
- Service Counter 132
- Service Entrance* 16
- Service Room* 16, 20, 31
- Service Space* 16, 20, 31
- Shelving 142, 171, 173
- Shower Stalls 162
- Sidelights 121
- Sidewalk 30, 74, 78
- Signage* 16, 44, 47,
 - Assistive Listening Systems 165
 - Character Height 47, 48
 - Elevators 123, 126
 - Entrances 112
 - Lockers and Storage Units 145
 - Parking 96, 97
 - Public Telephones 57
 - Toilets and Bathing Facilities 146
 - Vending and Ticketing Machines 56
 - Washrooms 158
- Site Improvement* 16
- Sleeping Accommodations* 16
- Space Requirements 24, 139, 142
- Speaking Ports 133
- Specialty Change Rooms 66, 143
- Spectator Areas 103
- Stairs 30, 40, 42
 - Detectable Warning Surfaces 52
 - Landing Criteria 40
 - Nosings 40
 - Treads 41
- Steps 100
- Storage 142
 - Reach Limits 142
 - Units 145
- Storage Elements 137, 182

- Street Elements* 16, 78
- Street Element Zone 16, 79
- Streetscape* 16, 78
- Structural Frame* 16
- Swimming Pools 66, 171
- Tables 134
- Tactile* 17
- Temporary Facility* 17
- Telephone Typewriter (TTY)* 17, 57
- Telephones, Public 57, 102, 168
- Texture 44
- Ticketing Machines 56
- Toilets 146, 150, 158, 171
- Toilet Stalls 148
- Traffic Signal Poles 81
 - Locations on Street 82
- Trails 101
- Training Facilities 181
- Transfer Space 149, 150
- Transfer Systems 106
- Transit Facilities 104
- Tree 101
- Tree Guard 30, 90
- Truncated Dome* 17, 32
- Truncated Dome Detectable
 - Warning Surfaces 83
- Turning Space (see Wheelchair)
- Turnstiles 34
- Utility Boxes 30
- Urinals 154
- Vehicular Way* 17
- Vending Machines 56
- Video Display Terminals 50
- Viewing Positions 69
- Visitable* 17
- Visual Alarms 164
- Waiting Areas 62
- Washrooms 102
 - (see Individual Washrooms)
- Washroom Accessories 156
- Washroom Dimensions 147
- Waterfront Areas 102
- Wayfinding* 17, 44
 - Acoustics 45
- Wheelchair
 - Access Widths 31
 - Access at Turnstiles 35
 - Clearances 24, 50
 - Doorways 114
 - Maneuverability 24
 - Ramp 104
 - Reach Allowances 27
 - Sight Lines in Assembly Seating 71
 - Turning Around an Obstacle 32
 - Turning Space 25
 - Window 121
 - Window Sill 121
 - Work Areas 136
 - Work Surfaces 134
 - Workplace Accommodations 177

